

## 1-Line Low Capacitance Bi-directional TVS Diode

### Features

- 400W peak pulse power (8/20 $\mu$ s)
- Ultra low capacitance: 0.6pF typical
- Ultra low leakage: nA level
- Low operating voltage: 3.3V
- Low clamping voltage
- Protects one power line or data line
- Complies with following standards:
  - IEC 61000-4-2 (ESD) immunity test  
 Air discharge:  $\pm 30$ kV  
 Contact discharge:  $\pm 30$ kV
  - IEC61000-4-4 (EFT) 80A (5/50ns)
  - IEC61000-4-5 (Lightning) 20A (8/20)
- RoHS Compliant

### Applications

- USB Ports
- Smart Phones
- Wireless Systems
- Ethernet 10/100/1000 Base T

### Mechanical Characteristics

- Package: SOD-323
- Lead Finish: Matte Tin
- Case Material: "Green" Molding Compound.
- UL Flammability Classification Rating 94V-0
- Quantity Per Reel: 3,000pcs
- Reel Size: 7 inch
- Device Marking: CC

### Dimensions SOD-323



### Pin Configuration

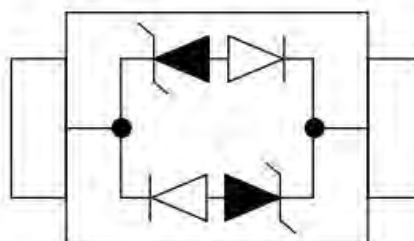

### Absolute Maximum Ratings (T<sub>amb</sub>=25°C unless otherwise specified)

Parameter	Symbol	Value	Unit
Peak Pulse Power (8/20 $\mu$ s)	P <sub>pp</sub>	400	W
ESD per IEC 61000-4-2 (Air)	V <sub>ESD</sub>	$\pm 30$	Kv
ESD per IEC 61000-4-2 (Contact)		$\pm 30$	
Operating Temperature Range	T <sub>J</sub>	-55 to +125	°C
Storage Temperature Range	T <sub>STJ</sub>	-55 to +150	°C

**Electrical Characteristics**(TA=25°C unless otherwise specified)

Symbol	Parameter	Conditions	Min	Typ	Max	Unit
VRWM	Reverse Working Peak Voltage				3.3	V
VBR	Reverse Breakdown Voltage	IT = 1mA	4			V
IR	Reverse Leakage Current	VRWM = 3.3V			0.2	μA
VC	Clamping Voltage	IPP = 1 A (8/20μs)			7	V
VC	Clamping Voltage	IPP = 20 A (8/20μs)			20	V
CJ	Capacitance	VR = 0V, f = 1MHz		0.6		pF

Typical Performance Characteristics (TA=25°C unless otherwise Specified)

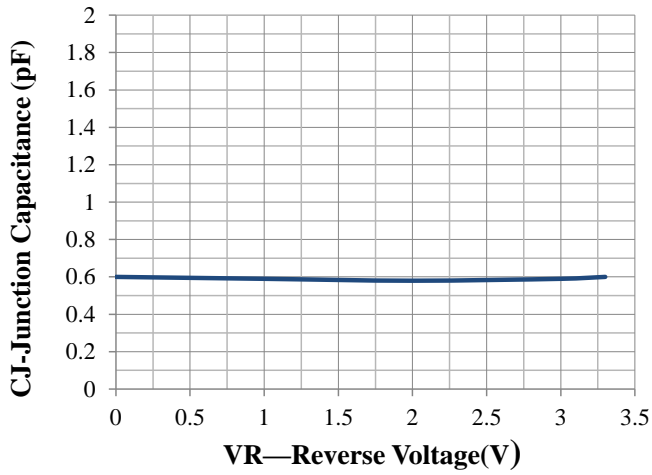

Junction Capacitance vs. Reverse Voltage

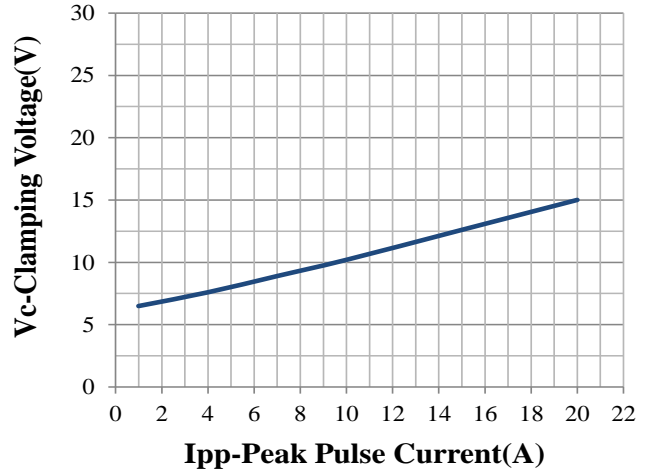

Clamping Voltage vs. Peak Pulse Current

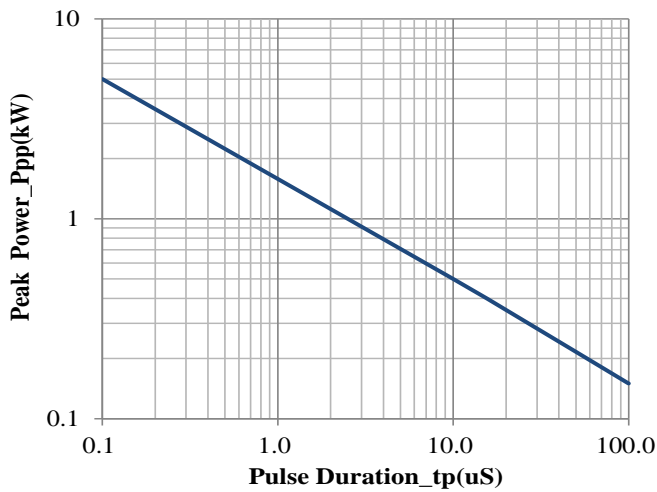

Peak Pulse Power vs. Pulse Time

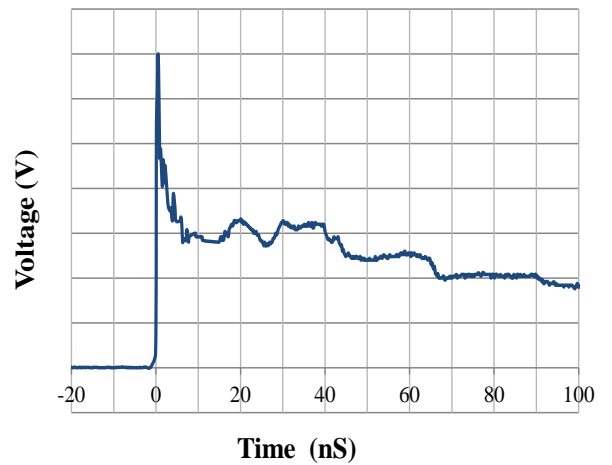

IEC61000-4-2 Pulse Waveform

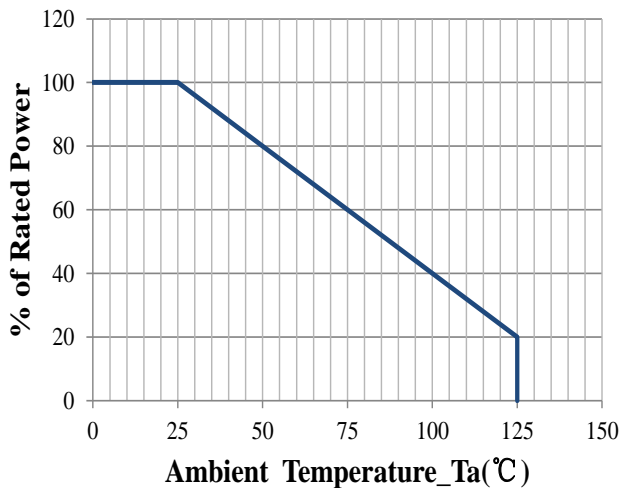

Power Derating Curve

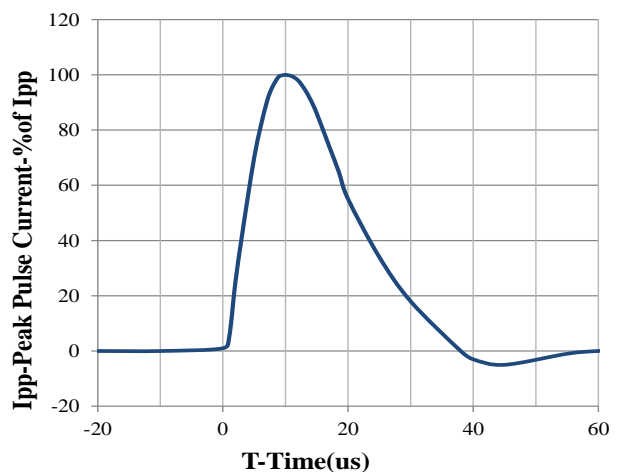

8 X 20us Pulse Waveform

**SOD-323 Package Outline & Dimensions**

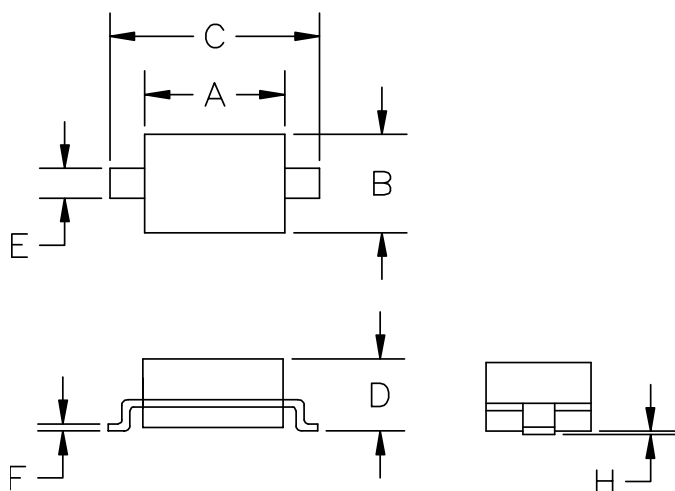

SYM	DIMENSIONS			
	MILLIMETERS		INCHES	
	MIN	MAX	MIN	MAX
A	1.50	1.80	0.060	0.071
B	1.20	1.40	0.045	0.054
C	2.30	2.70	0.090	0.107
D	-	1.10	-	0.043
E	0.30	0.40	0.012	0.016
F	0.10	0.25	0.004	0.010
H	-	0.10	-	0.004

**Suggested Land Pattern**

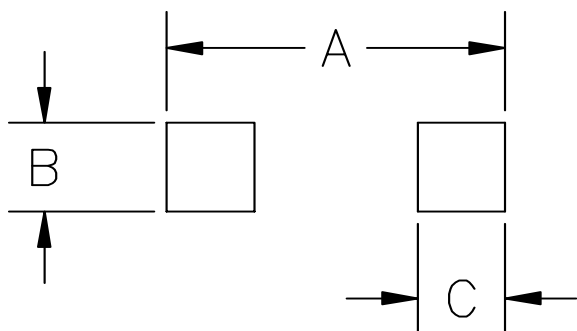

SYM	DIMENSIONS	
	MILLIMETERS	INCHES
A	3.15	0.120
B	0.80	0.031
C	0.80	0.031