

Ultra Low Capacitance TVS Diode Array

Features

- Ultra low capacitance: 0.12pF typical (I/O to I/O)
- Ultra low leakage: nA level
- Low operating voltage: 5V
- Low clamping voltage with snap back technology
- Up to 4 lines protects
- Leadless flow -through package
- Complies with following standards:
 - IEC 61000-4-2 (ESD) immunity test
 Air discharge: ± 15 kV
 Contact discharge: ± 15 kV
 - IEC61000-4-4 (EFT) 40A (5/50ns)
 - IEC61000-4-5 (Lightning) 6A (8/20 μ s)
- RoHS Compliant

Dimensions DFN2510P10

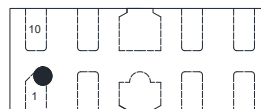

Pin Configuration

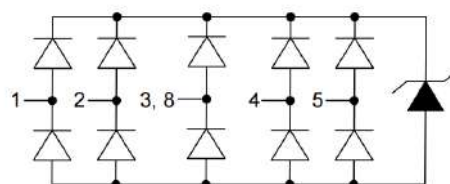

Applications

- HDMI 1.3 & 1.4, USB 2.0 & 3.0 and MDDI ports
- Monitors and flat panel displays
- Set -top box and Digital TV
- Video graphics cards
- Digital Video Interface (DVI)
- Notebook Computers
- PCI Express and Serial SATA Ports

Mechanical Characteristics

- Package: DFN2510P10
- Lead Finish: Matte Tin
- UL Flammability Classification Rating 94V-0
- Quantity Per Reel:3000pcs
- Reel Size:7inch
- Device Marking:3V4BS

Absolute Maximum Ratings (Tamb=25°C unless otherwise specified)

Parameter	Symbol	Value	Unit
Peak Pulse Power (8/20 μ s)	P _{pp}	50	W
ESD per IEC 61000-4-2 (Air)	V _{ESD}	± 15	kV
ESD per IEC 61000-4-2 (Contact)		± 15	
Operating Temperature Range	T _J	-40 to +125	°C
Storage Temperature Range	T _{STJ}	-55 to +150	°C

Electrical Characteristics(TA=25°C unless otherwise specified)

Parameter	Symbol	Conditions	Min.	Typ.	Max.	Units
Reverse Stand-off Voltage	V_{RWM}				5	V
Reverse Breakdown Voltage	V_{BR}	$I_T=1mA$	5.5	8.0		V
Reverse Leakage Current	I_R	$V_{RWM}=5V$			100	nA
Clamping Voltage	V_{CL}	$I_{PP}=1A$; $t_p=8/20\mu s$		2.5	4.0	V
Clamping Voltage	V_{CL}	$I_{PP}=6A$; $t_p=8/20\mu s$		5.5	7.0	V
Junction Capacitance	C_J	$V_R=0V$; $f=1MHz$; IO-GND		0.18	0.20	pF
		$V_R=0V$; $f=1MHz$; IO-IO		0.12	0.15	

Electrical Parameters(TA=25°C unless otherwise specified)

Symbol	Parameters
V_{RWM}	Reverse stand-off voltage
I_R	Reverse leakage current
V_{BR}	Reverse breakdown voltage
I_{BR}	Reverse breakdown current
V_{CL}	Clamping voltage
V_{TRIG}	Reverse trigger voltage
I_{TRIG}	Reverse trigger current
V_{HOLD}	Reverse holding voltage
I_{HOLD}	Reverse holding current
I_{PP}	Peak pulse current

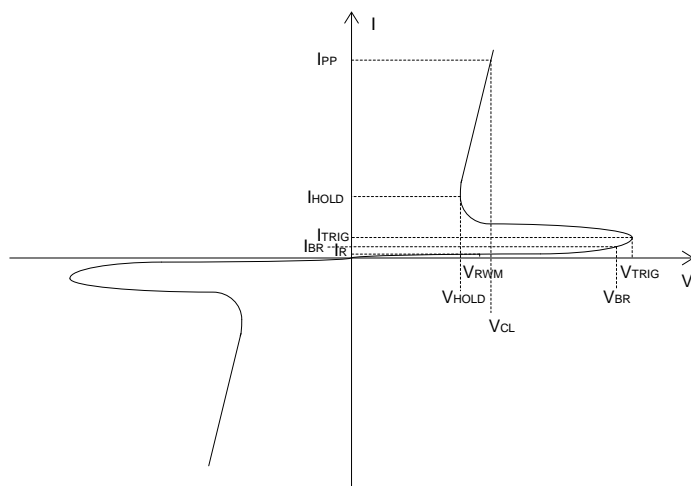

Typical Characteristics

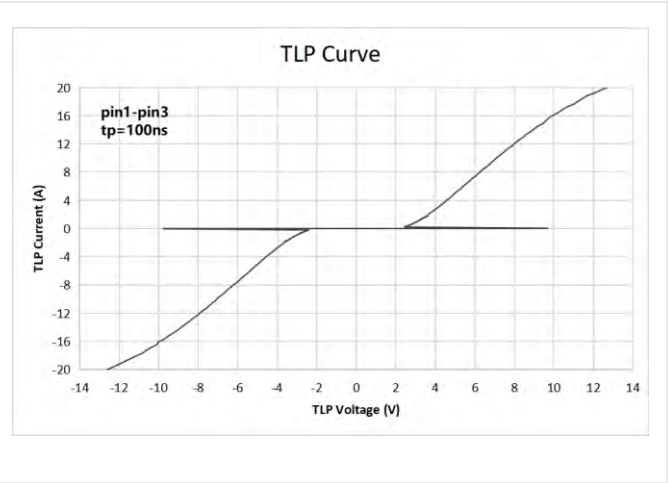
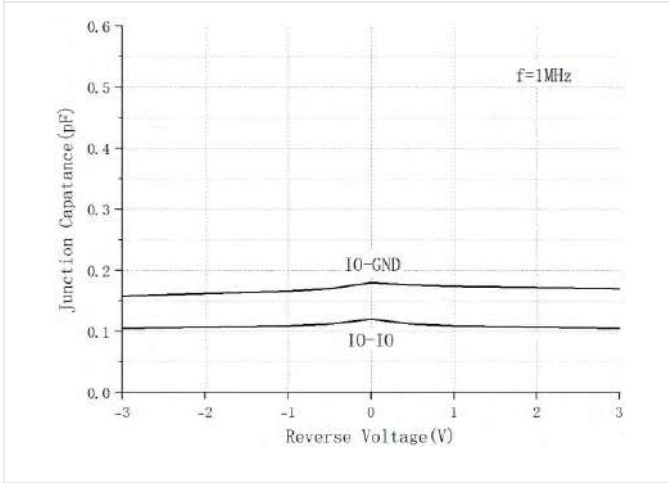
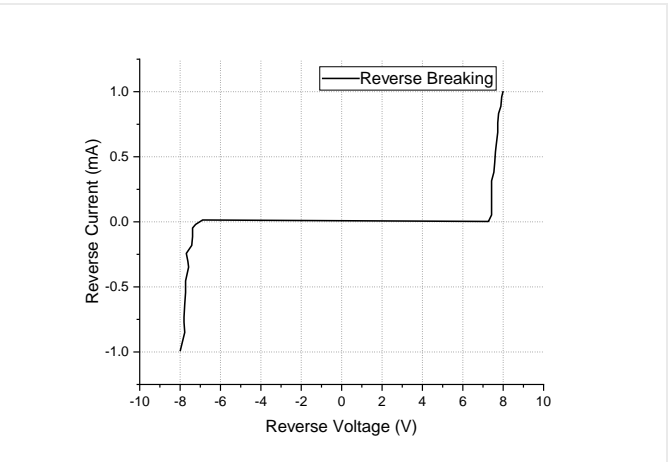
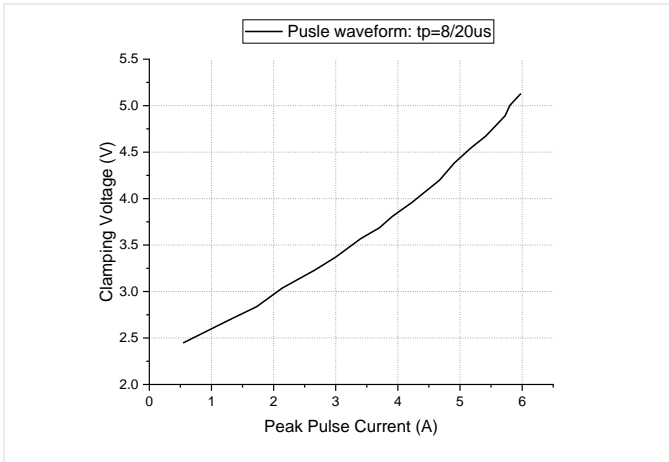

Measurement Wave According to IEC Standard

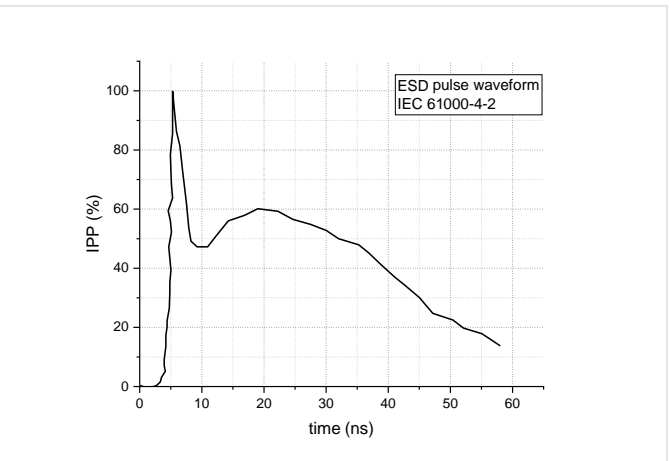
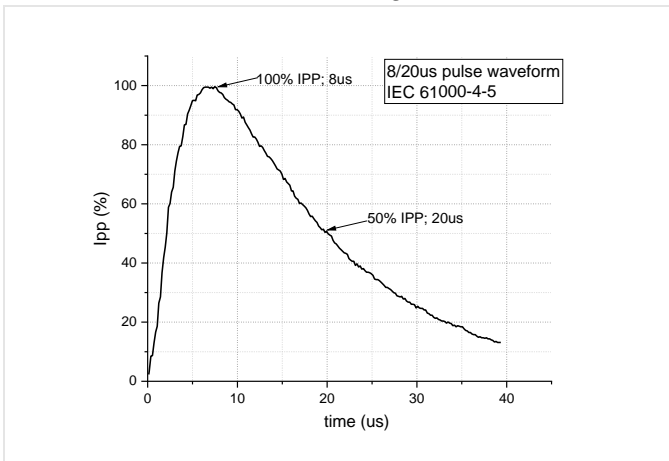

Typical Application

The KWULC0524BP10 is designed for easy PCB layout by allowing the traces to run straight through the device. The PCB traces could be used to connect the pin pairs for each line. For example, line 1 enters at pin 1 and exits at pin 10 and the PCB trace connects Pin 1 and Pin 10 together. Ground is connected at Pin 3 and Pin 8.

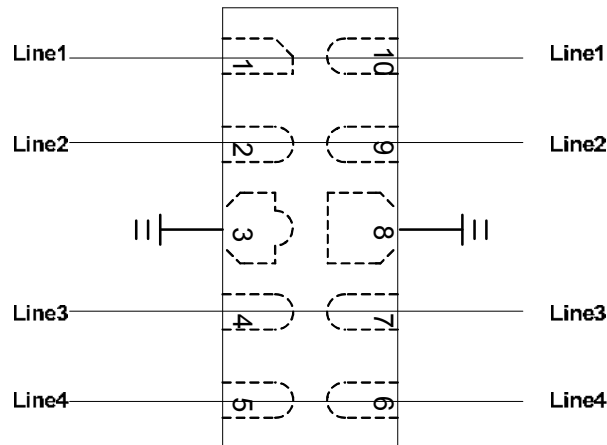

KWULC0524BP10 on USB 3.0 Port Application

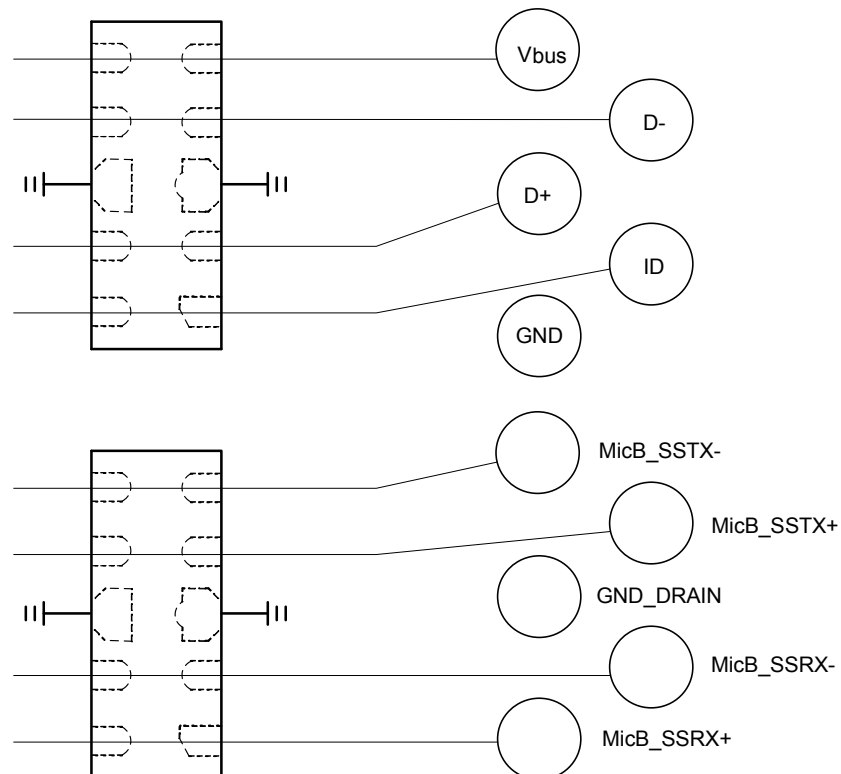

KWULC0524BP10 on DVI Port Application

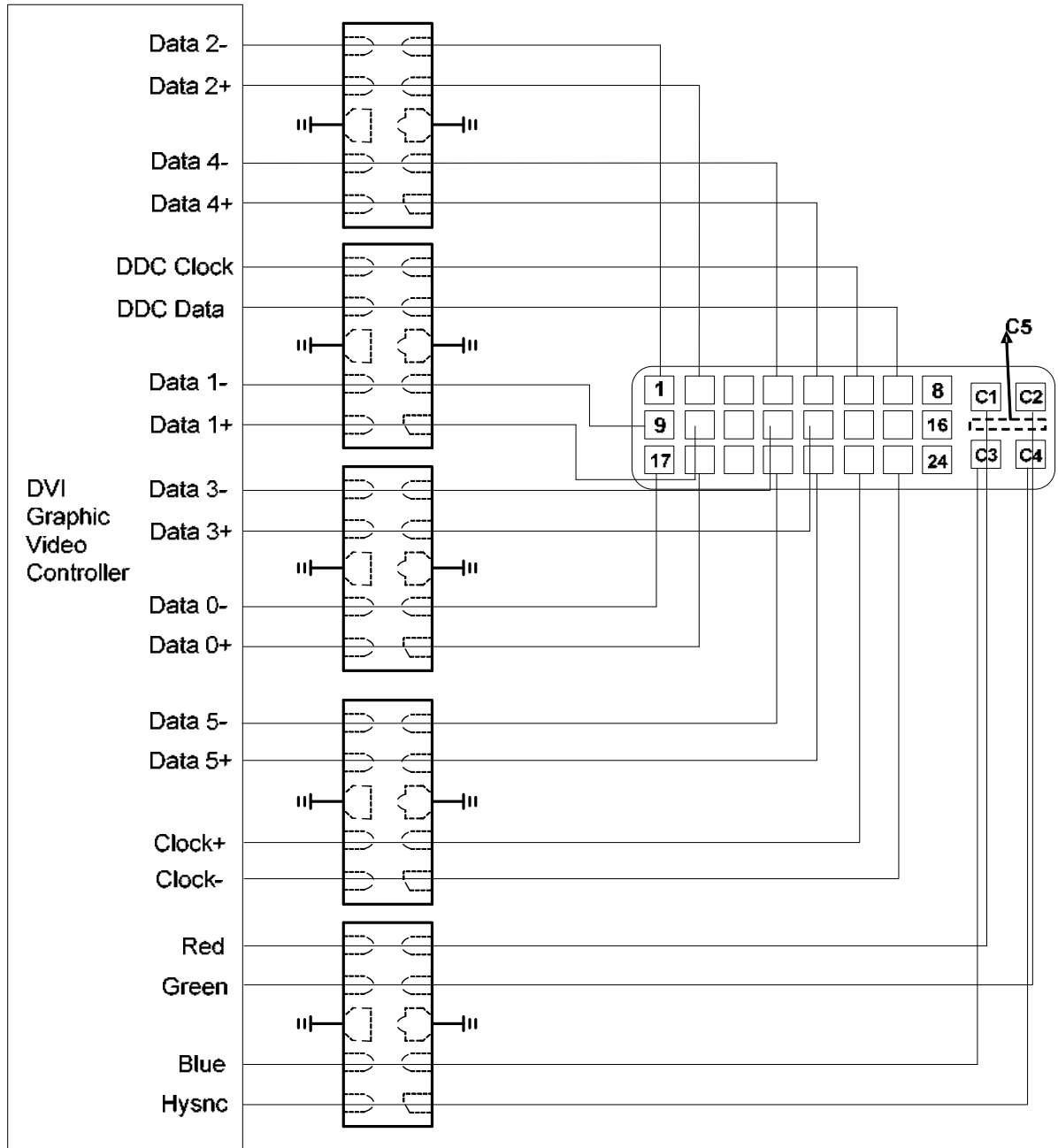

KWULC0524BP10 on HDMI Port Application

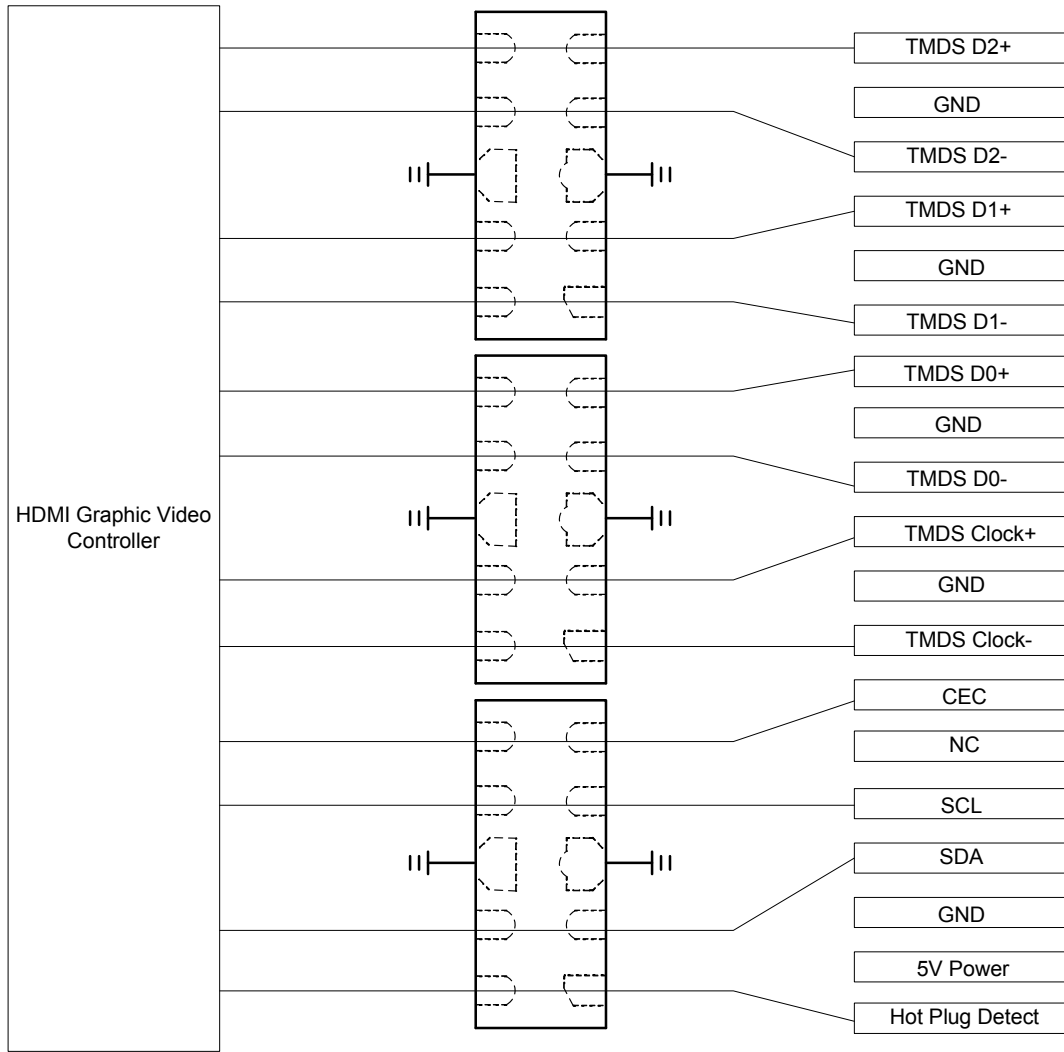

KWULC0524BP10 on MDDI Port Application

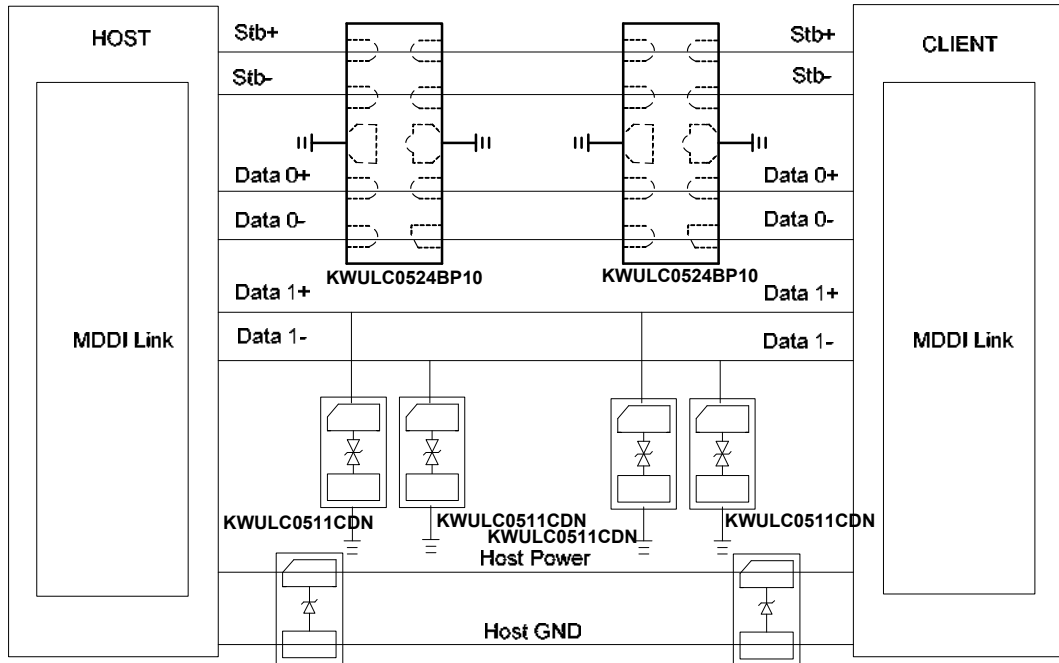

KWULC0524BP10 on 10/100 Base Ethernet Port Application

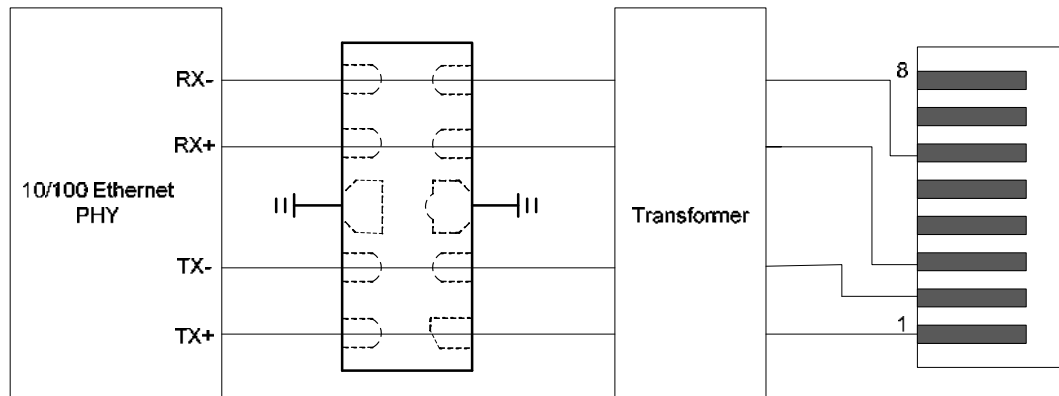

KWULC0524BP10 on VGA Port Application

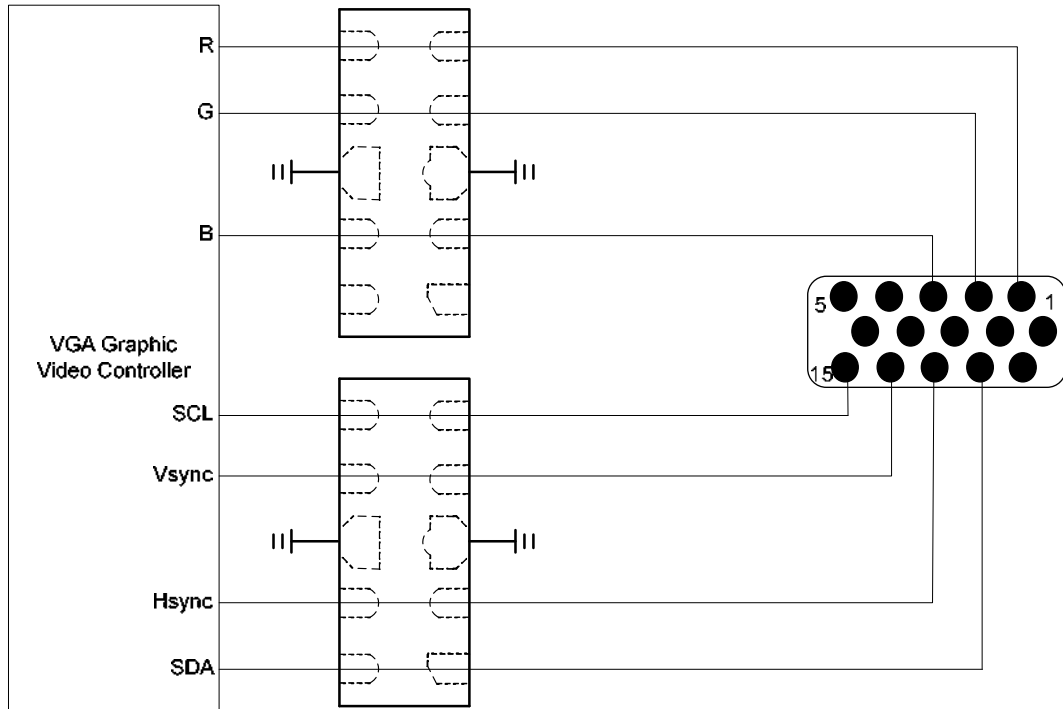

KWULC0524BP10 on eSATA Port Application

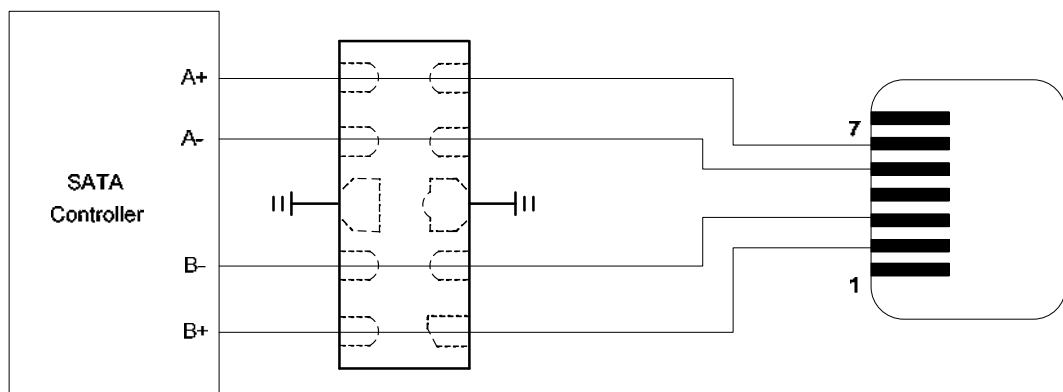

DFN2510P10 Package Outline Drawing

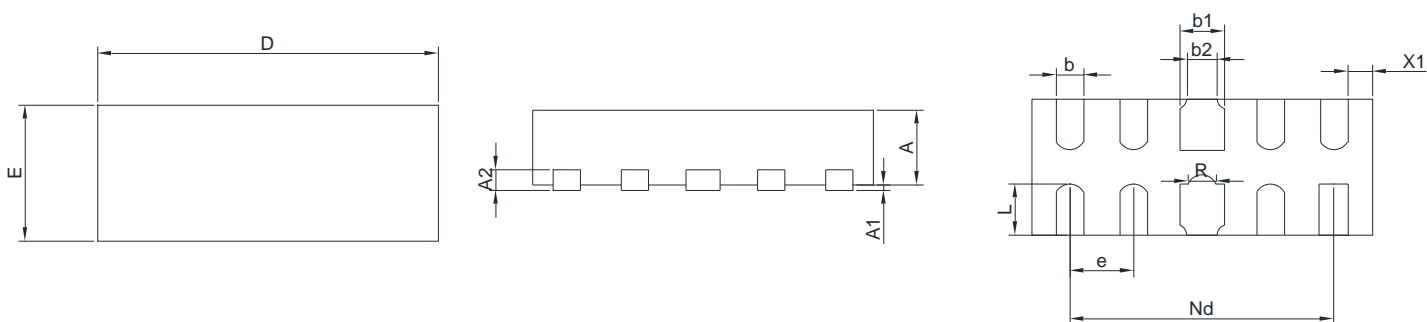

Dimensions in Millimeter(mm)					
SYMBOL	MIN	MAX	SYMBOL	MIN	MAX
A	0.50	0.60	b2	0.20REF	
A1	0.00	0.05	D	2.45	2.55
A2	0.15REF		E	0.95	1.05
b	0.15	0.25	L	0.33	0.43
b1	0.35	0.45	e	0.50BSC	
Nd	2.00BSC		X1	0.08	0.22

Recommended Soldering Footprint

