

7.0A 650V N-CHANNEL POWER MOSFET

Description:

The KWNJ7N65 is an N-channel mode power MOSFET using advanced technology to provide customers with planar stripe and DMOS technology. This technology specializes in allowing a minimum on-state resistance and superior switching performance. It also can withstand high energy pulse in the avalanche and commutation mode. The KWNJ7N80 is universally applied in high efficiency switch mode power supply.

Features:

- * $V_{DS} = 650V$
- * $I_D = 7.0A$
- * $R_{DS(on)} = 1.8 \text{ ohm}@V_{GS} = 10V$
- * High switching speed
- * 100% avalanche tested

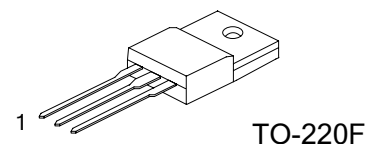
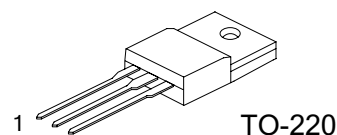

■ SYMBOL

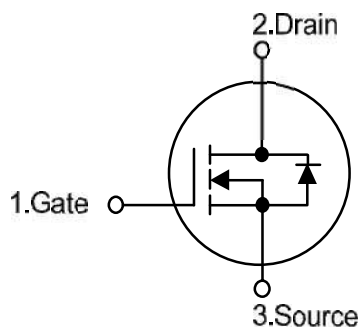

■ ORDERING INFORMATION

Ordering Number	Package	Pin Assignment			Packing
		1	2	3	
KWNJ7N65-LI	TO-220	G	D	S	Tape Box
KWNJ7N65-BL	TO-220	G	D	S	Bulk
KWNJ7N65F-LI	TO-220F	G	D	S	Tube

Note: Pin Assignment: G: Gate D: Drain S: Source

■ **ABSOLUTE MAXIMUM RATINGS** ($T_C = 25^\circ\text{C}$, unless otherwise specified)

PARAMETER		SYMBOL	RATINGS	UNIT
Drain-Source Voltage		V_{DSS}	650	V
Gate-Source Voltage		V_{GSS}	± 30	V
Avalanche Current (Note 2)		I_{AR}	7.4	A
Drain Current	Continuous	I_D	7.4	A
	Pulsed (Note 2)	I_{DM}	29.6	A
Avalanche Energy	Single Pulsed (Note 3)	E_{AS}	530	mJ
	Repetitive (Note 2)	E_{AR}	14.2	mJ
Peak Diode Recovery dv/dt (Note 4)		dv/dt	4.5	V/ns
Power Dissipation	TO-220	P_D	142	W
	TO-220F		48	
Junction Temperature		T_J	+150	$^\circ\text{C}$
Storage Temperature		T_{STG}	-55 ~ +150	$^\circ\text{C}$

- Notes: 1. Absolute maximum ratings are those values beyond which the device could be permanently damaged. Absolute maximum ratings are stress ratings only and functional device operation is not implied.
 2. Repetitive Rating : Pulse width limited by maximum junction temperature
 3. $L = 19.5\text{mH}$, $I_{AS} = 7.4\text{A}$, $V_{DD} = 50\text{V}$, $R_G = 25\ \Omega$, Starting $T_J = 25^\circ\text{C}$
 4. $I_{SD} \leq 7.4\text{A}$, $di/dt \leq 200\text{A}/\mu\text{s}$, $V_{DD} \leq BV_{DSS}$, Starting $T_J = 25^\circ\text{C}$

■ **THERMAL DATA**

PARAMETER		SYMBOL	RATINGS	UNIT
Junction to Ambient		θ_{JA}	62.5	$^\circ\text{C}/\text{W}$
Junction to Case	TO-220	θ_{JC}	0.88	$^\circ\text{C}/\text{W}$
	TO-220F		2.6	

■ **ELECTRICAL CHARACTERISTICS** ($T_C = 25^\circ\text{C}$, unless otherwise specified)

PARAMETER	SYMBOL	TEST CONDITIONS	MIN	TYP	MAX	UNIT
OFF CHARACTERISTICS						
Drain-Source Breakdown Voltage	BV_{DSS}	$V_{GS} = 0V, I_D = 250\mu A$	650			V
Drain-Source Leakage Current	I_{DSS}	$V_{DS} = 650V, V_{GS} = 0V$			1	μA
Gate- Source Leakage Current	Forward	I_{GSS} $V_{GS} = 30V, V_{DS} = 0V$			100	nA
	Reverse		$V_{GS} = -30V, V_{DS} = 0V$		-100	nA
Breakdown Voltage Temperature Coefficient	$\Delta BV_{DSS} / \Delta T_J$	$I_D = 250\mu A$, Referenced to 25°C		0.67		$V/^\circ\text{C}$
ON CHARACTERISTICS						
Gate Threshold Voltage	$V_{GS(TH)}$	$V_{DS} = V_{GS}, I_D = 250\mu A$	2.0		4.0	V
Static Drain-Source On-State Resistance	$R_{DS(ON)}$	$V_{GS} = 10V,$ $I_D = 3.7A$	KWNJ7N65	0.94	1.2	Ω
			KWNJ7N65-F	0.94	1.2	
DYNAMIC CHARACTERISTICS						
Input Capacitance	C_{ISS}	$V_{DS} = 25V, V_{GS} = 0V,$ $f = 1.0\text{ MHz}$			1400	pF
Output Capacitance	C_{OSS}				180	pF
Reverse Transfer Capacitance	C_{RSS}			16	21	pF
SWITCHING CHARACTERISTICS						
Turn-On Delay Time	$t_{D(ON)}$	$V_{DD} = 325V, I_D = 7.4A,$ $R_G = 25\Omega$ (Note 1, 2)			70	ns
Turn-On Rise Time	t_R				170	ns
Turn-Off Delay Time	$t_{D(OFF)}$				140	ns
Turn-Off Fall Time	t_F				130	ns
SWITCHING CHARACTERISTICS						
Total Gate Charge	Q_G	$V_{DS} = 520V, I_D = 7.4A,$ $V_{GS} = 10V$ (Note 1, 2)		29	38	nC
Gate-Source Charge	Q_{GS}			7		nC
Gate-Drain Charge	Q_{GD}			14.5		nC
DRAIN-SOURCE DIODE CHARACTERISTICS AND MAXIMUM RATINGS						
Drain-Source Diode Forward Voltage	V_{SD}	$V_{GS} = 0V, I_S = 7.4A$			1.4	V
Maximum Continuous Drain-Source Diode Forward Current	I_S				7.4	A
Maximum Pulsed Drain-Source Diode Forward Current	I_{SM}				29.6	A
Reverse Recovery Time	t_{rr}	$V_{GS} = 0V, I_S = 7.4A,$		320		ns
Reverse Recovery Charge	Q_{RR}	$di_F / dt = 100A/\mu s$ (Note 1)		2.4		μC

- Notes: 1. Pulse Test: Pulse width $\leq 300\mu s$, Duty cycle $\leq 2\%$
 2. Essentially independent of operating temperature

■ **CLASSIFICATION OF $R_{DS(ON)}$**

RANK	-	F
VALUE	1.2 Ω	1.2 Ω

■ **TEST CIRCUITS AND WAVEFORMS**

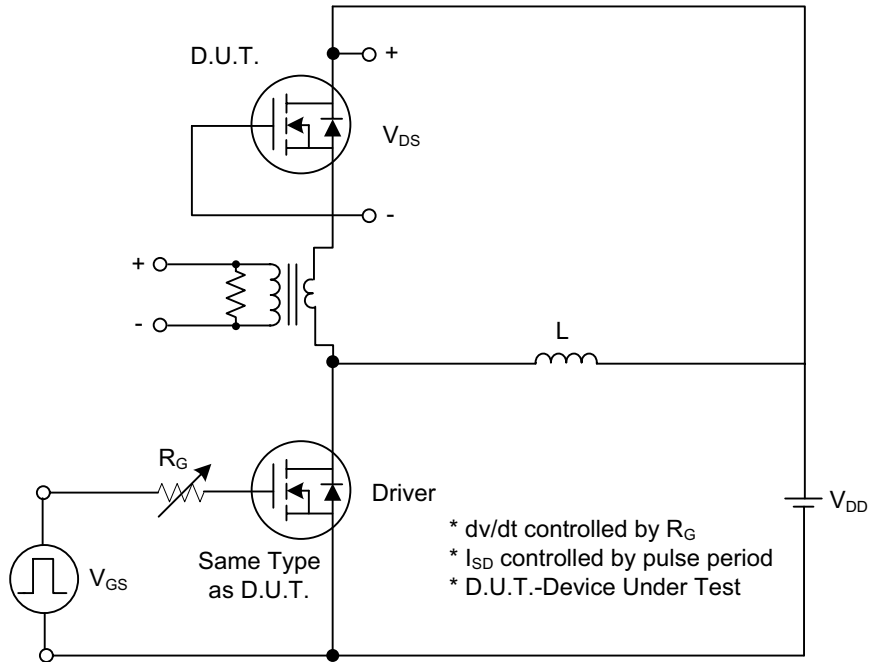

Peak Diode Recovery dv/dt Test Circuit

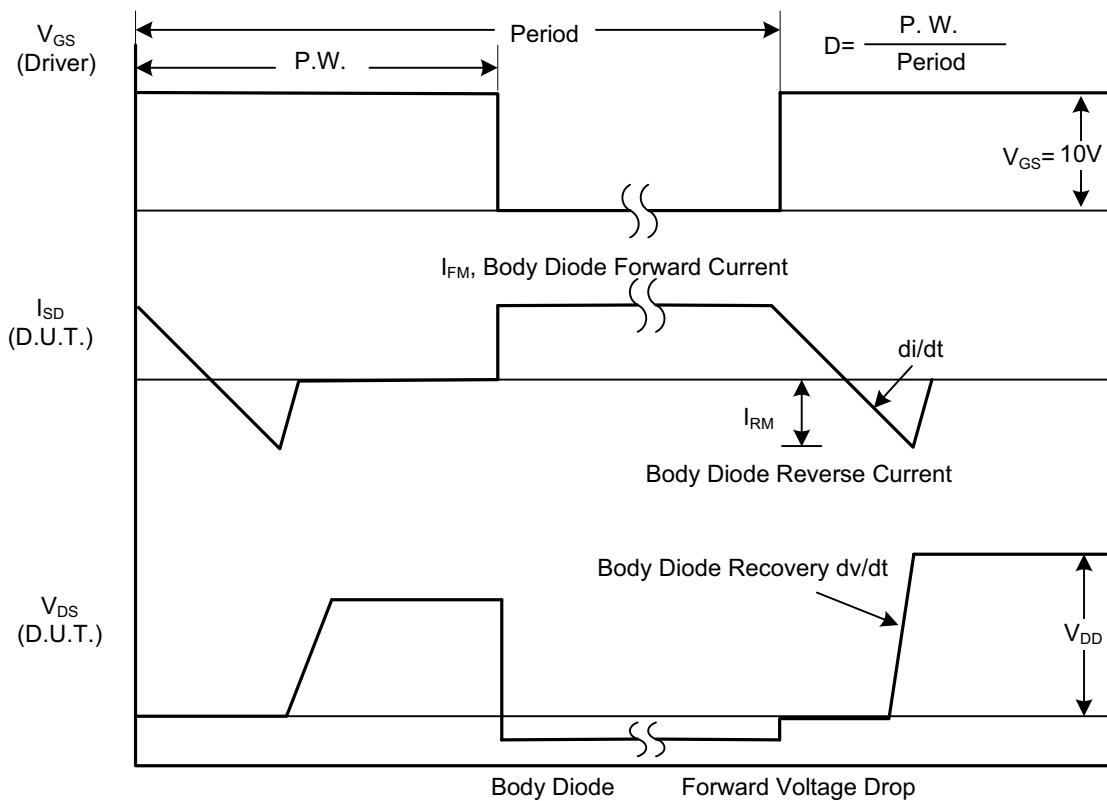

Peak Diode Recovery dv/dt Waveforms

■ **TEST CIRCUITS AND WAVEFORMS (Cont.)**

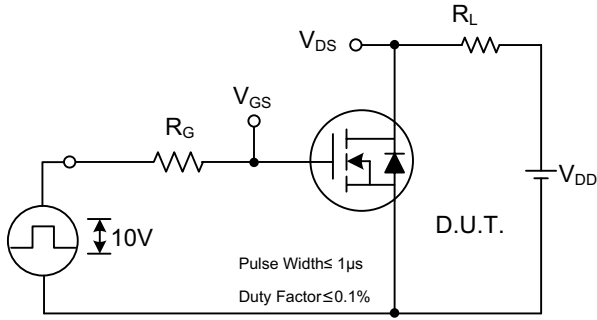

Switching Test Circuit

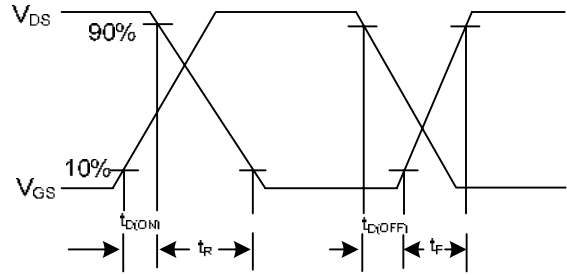

Switching Waveforms

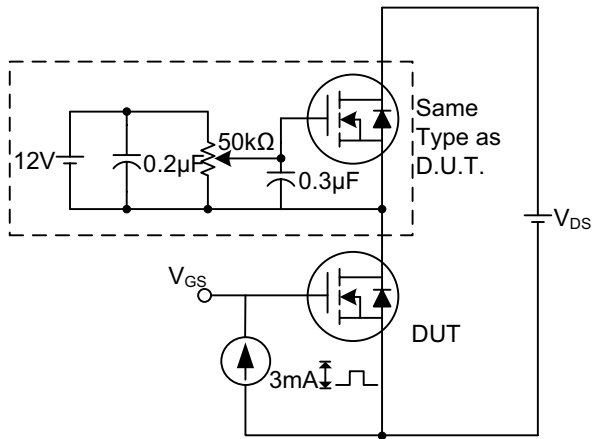

Gate Charge Test Circuit

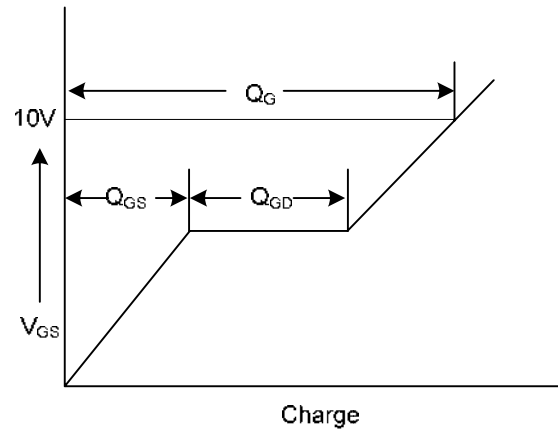

Gate Charge Waveform

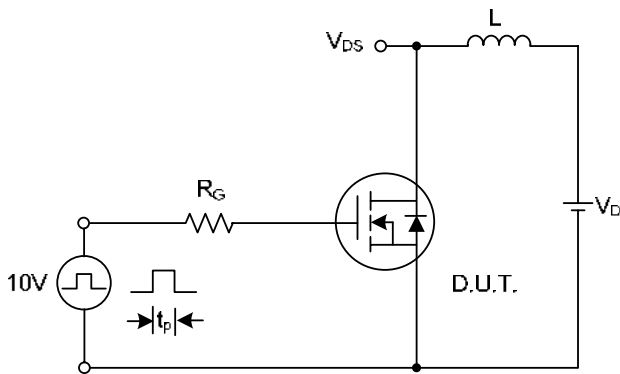

Unclamped Inductive Switching Test Circuit

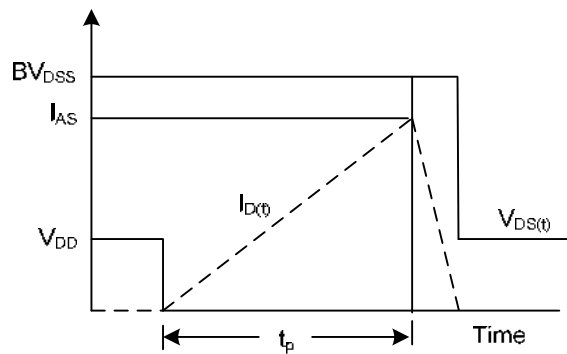

Unclamped Inductive Switching Waveforms

■ **TYPICAL CHARACTERISTICS**

On-State Characteristics

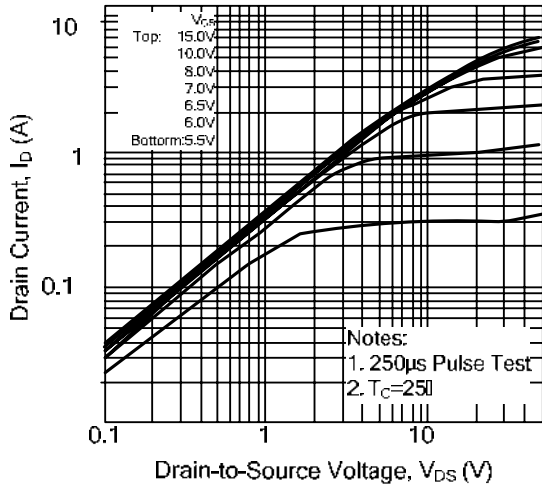

Transfer Characteristics

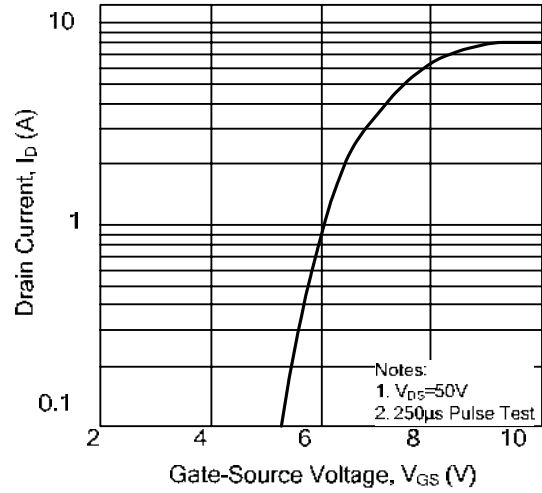

On-Resistance Variation vs. Drain Current and Gate Voltage

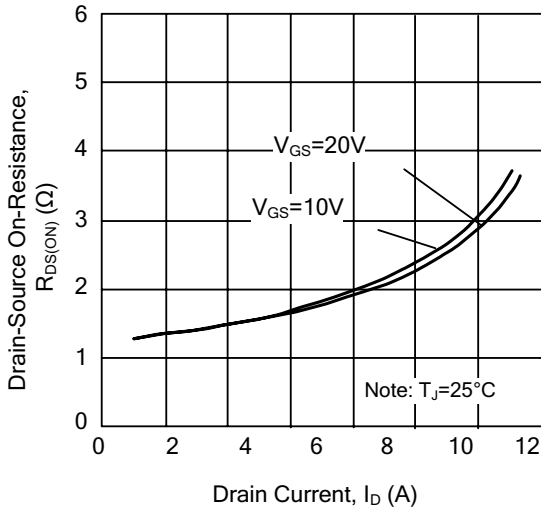

On State Current vs. Allowable Case Temperature

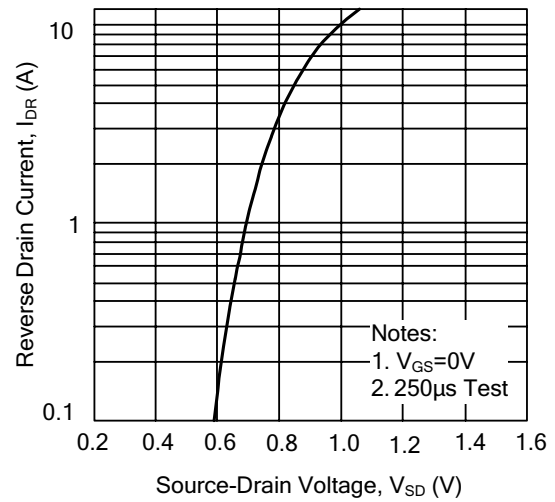

Capacitance Characteristics (Non-Repetitive)

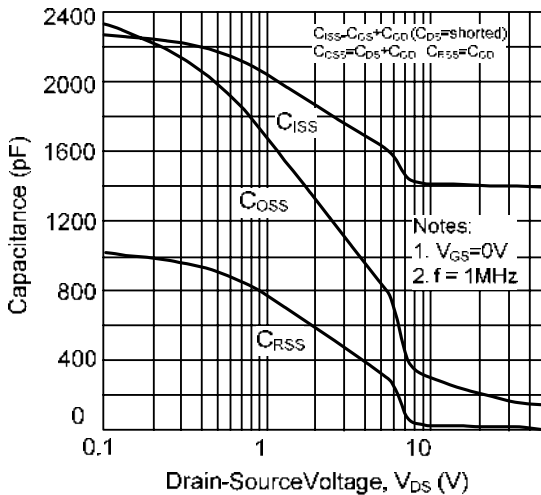

Gate Charge Characteristics

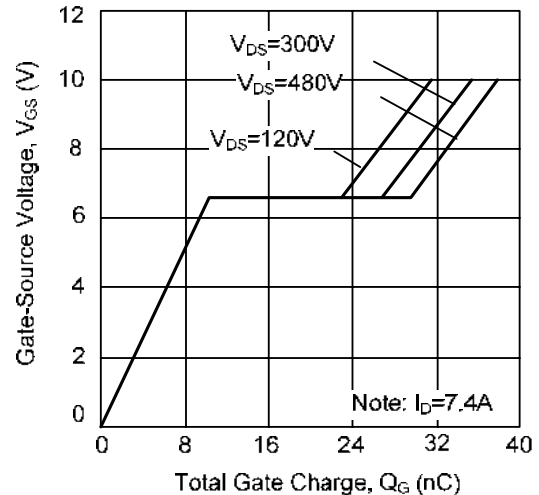

■ **TYPICAL CHARACTERISTICS(Cont.)**

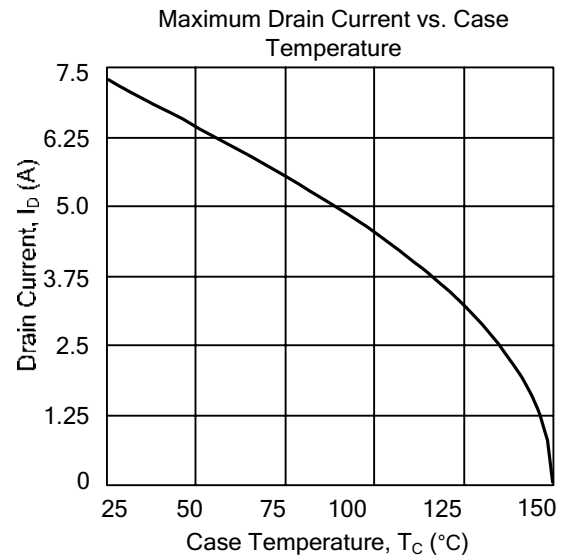
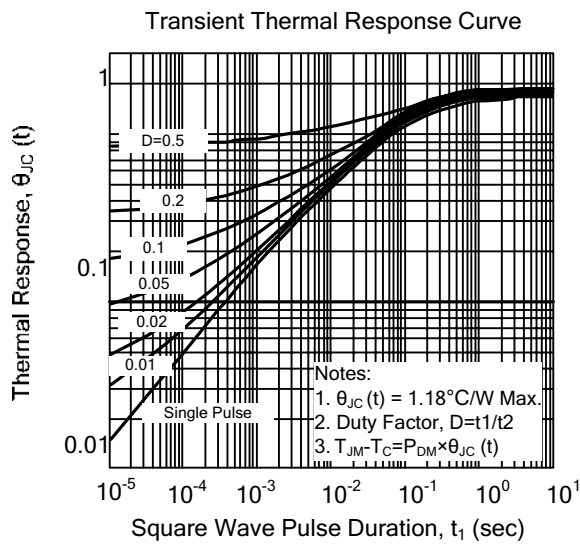
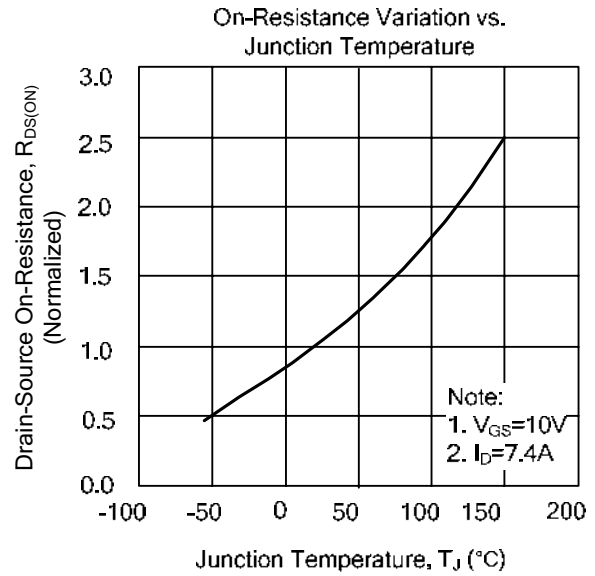
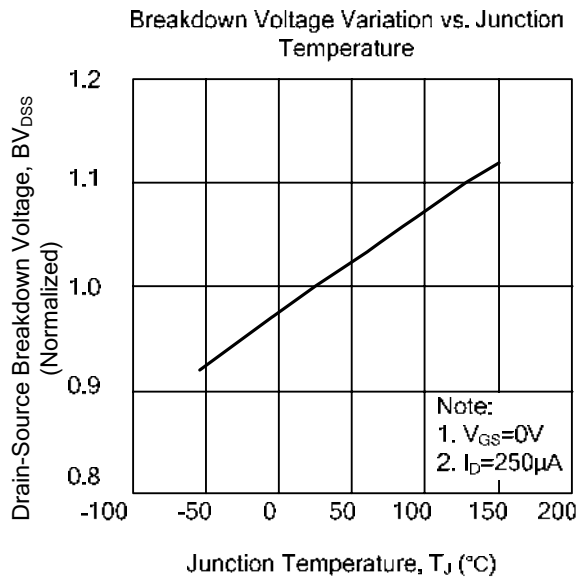

Safe Operating Area - 650V

