

SOT-23 Plastic-Encapsulate MOSFETS

N-Channel MOSFET

FEATURE

- TrenchFET Power MOSFET
- Low $R_{DS(ON)}$
- Surface Mount Package

APPLICATION

- DC/DC Converters
- Load Switch
- LED Backlighting in LCD TVs

$V_{(BR)DSS}$	$R_{DS(on)MAX}$	I_D
100V	234mΩ@10V	2A
	267mΩ@6V	
	278mΩ@4.5V	

SOT-23

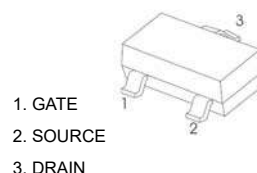

Equivalent Circuit

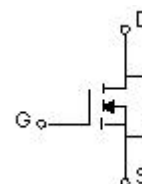

MARKING: S24



ABSOLUTE MAXIMUM RATINGS ($T_a=25^{\circ}C$ unless otherwise noted)

Parameter	Symbol	Value	Unit
Drain-Source Voltage	V_{DS}	100	V
Gate-Source Voltage	V_{GS}	±20	V
Continuous Drain Current	I_D	2	A
Pulsed Drain Current	I_{DM}^*	8	A
Maximum Power Dissipation	P_D	0.35	W
Thermal Resistance from Junction to Ambient	$R_{\theta JA}$	357	$^{\circ}C/W$
Operation Junction and Storage Temperature Range	T_J, T_{STG}	-55~+150	$^{\circ}C$
Lead Temperature for Soldering Purposes(1/8" from case for 10 s)	T_L	260	$^{\circ}C$

*Repetitive rating: Pulse width limited by junction temperature.

MOSFET ELECTRICAL CHARACTERISTICS

$T_a=25^\circ\text{C}$ unless otherwise specified

Parameter	Symbol	Test Condition	Min	Typ	Max	Unit
STATIC PARAMETERS						
Drain-source breakdown voltage	$V_{(BR)DSS}$	$V_{GS} = 0V, I_D = 250\mu A$	100			V
Zero gate voltage drain current	I_{DSS}	$V_{DS} = 100V, V_{GS} = 0V$			1	μA
Gate-body leakage current	I_{GSS}	$V_{GS} = \pm 20V, V_{DS} = 0V$			± 100	nA
Gate threshold voltage(note 1)	$V_{GS(th)}$	$V_{DS} = V_{GS}, I_D = 250\mu A$	1.2		2.8	V
Drain-source on-resistance (note 1)	$R_{DS(on)}$	$V_{GS} = 10V, I_D = 1.5A$		195	234	m Ω
		$V_{GS} = 6V, I_D = 1A$		200	267	m Ω
		$V_{GS} = 4.5V, I_D = 0.5A$		208	278	m Ω
Forward transconductance (note 1)	g_{FS}	$V_{DS} = 20V, I_D = 1.5A$		2		S
Diode forward voltage (note 1)	V_{SD}	$I_S = 1.3A, V_{GS} = 0V$			1.2	V
DYNAMIC PARAMETERS (note2)						
Input Capacitance	C_{iss}	$V_{DS} = 50V, V_{GS} = 0V, f = 1MHz$		190		pF
Output Capacitance	C_{oss}			22		pF
Reverse Transfer Capacitance	C_{rss}			13		pF
Gate Resistance	R_g	$F = 1MHz$	0.3		2.8	Ω
SWITCHING PARAMETERS (note 2)						
Turn-on delay time	$t_{d(on)}$	$V_{DD} = 50V, V_{GEN} = 4.5V$ $R_L = 39\Omega, R_G = 1\Omega, I_D = 1.3A$			45	ns
Turn-on rise time	t_r				39	ns
Turn-off delay time	$t_{d(off)}$				26	ns
Turn-off fall time	t_f				20	ns
Total Gate Charge	Q_g	$V_{DS} = 50V, V_{GS} = 4.5V, I_D = 1.6A$			5.8	nC
Gate-Source Charge	Q_{gs}			0.75		nC
Gate-Drain Charge	Q_{gd}			1.4		nC

- Notes :**
1. Pulse Test : Pulse width $\leq 300\mu s$, duty cycle $\leq 0.5\%$.
 2. Guaranteed by design, not subject to production testing.

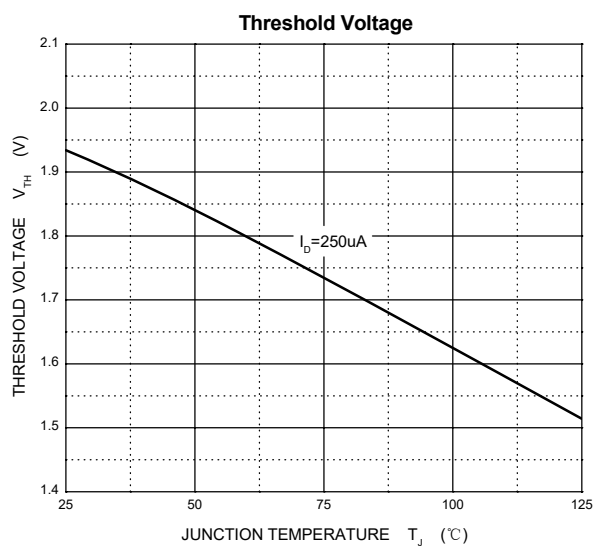
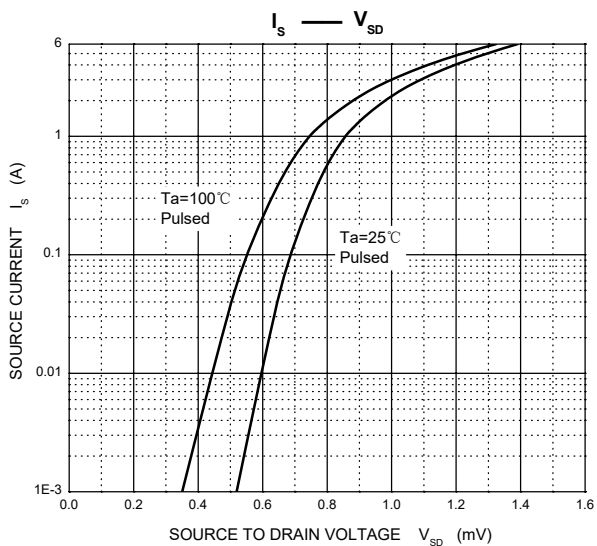
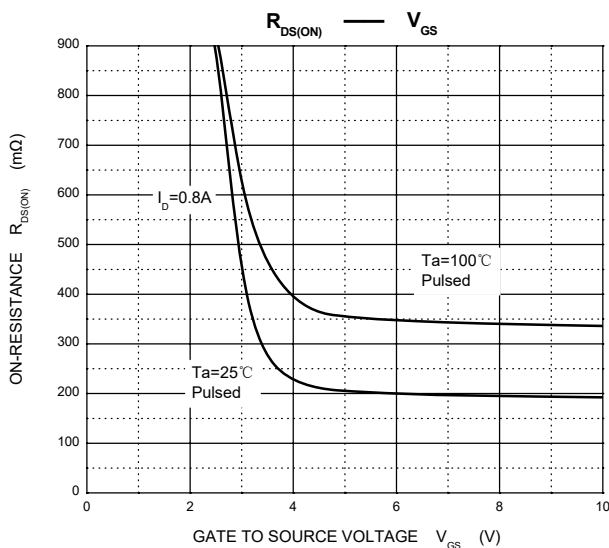
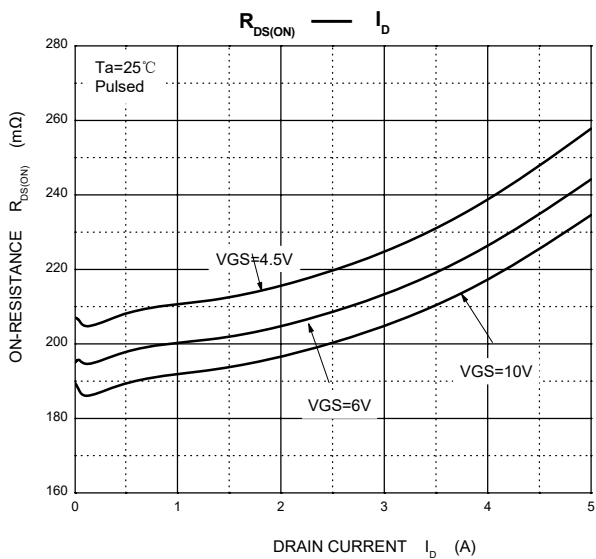
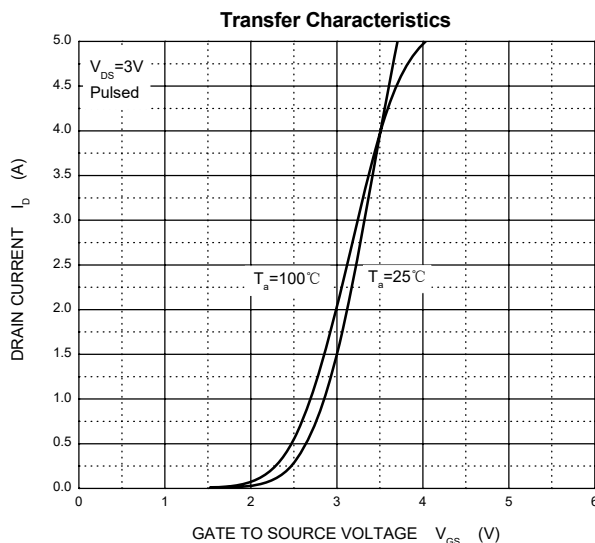
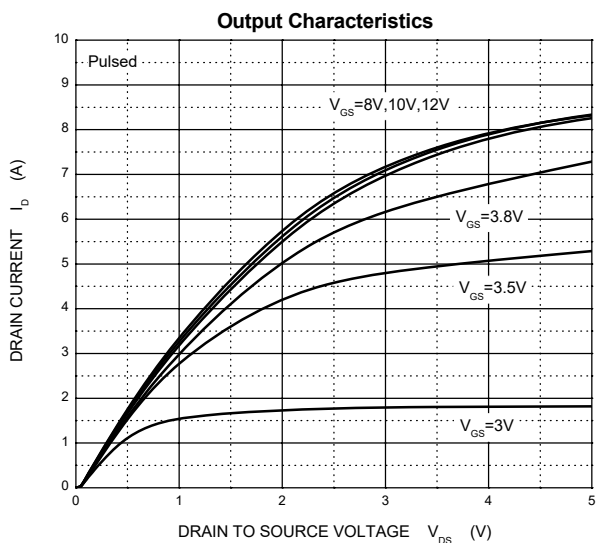

SOT-23 Package Outline Dimensions

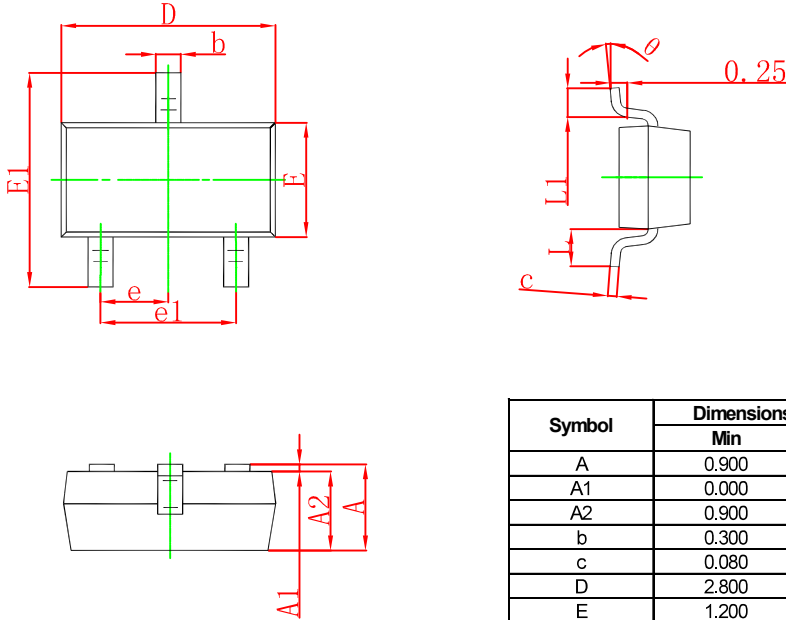

Symbol	Dimensions In Millimeters		Dimensions In Inches	
	Min	Max	Min	Max
A	0.900	1.150	0.035	0.045
A1	0.000	0.100	0.000	0.004
A2	0.900	1.050	0.035	0.041
b	0.300	0.500	0.012	0.020
c	0.080	0.150	0.003	0.006
D	2.800	3.000	0.110	0.118
E	1.200	1.400	0.047	0.055
E1	2.250	2.550	0.089	0.100
e	0.950 TYP		0.037 TYP	
e1	1.800	2.000	0.071	0.079
L	0.550 REF		0.022 REF	
L1	0.300	0.500	0.012	0.020
θ	0°	8°	0°	8°

SOT-23 Suggested Pad Layout

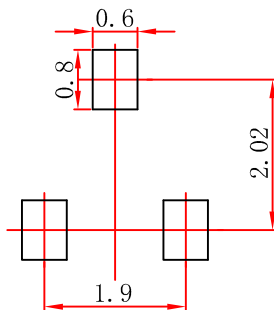

- Note:
1. Controlling dimension: in millimeters.
 2. General tolerance: ± 0.05mm.
 3. The pad layout is for reference purposes only

SOT-23 Tape and reel

SOT-23 Embossed Carrier Tape

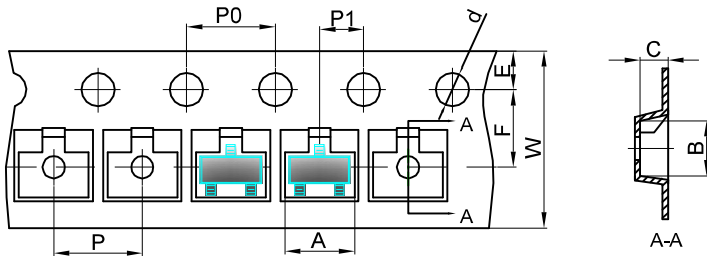

Packaging Description:

SOT-23 parts are shipped in tape. The carrier tape is made from a dissipative (carbon filled) polycarbonate resin. The cover tape is a multilayer film (Heat Activated Adhesive in nature) primarily composed of polyester film, adhesive layer, sealant, and anti-static sprayed agent. These reeled parts in standard option are shipped with 3,000 units per 7" or 17.8cm diameter reel. The reels are clear in color and is made of polystyrene plastic (anti-static coated).

Dimensions are in millimeter										
Pkg type	A	B	C	d	E	F	P0	P	P1	W
SOT-23	3.15	2.77	1.22	Ø1.50	1.75	3.50	4.00	4.00	2.00	8.00

SOT-23 Tape Leader and Trailer

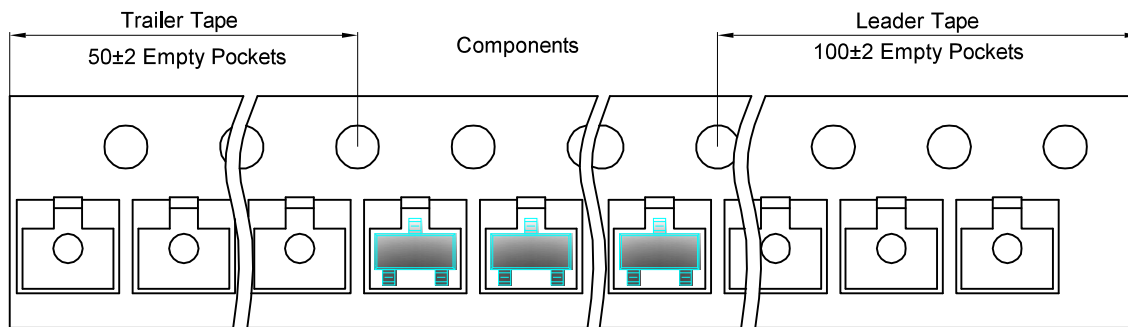

SOT-23 Reel

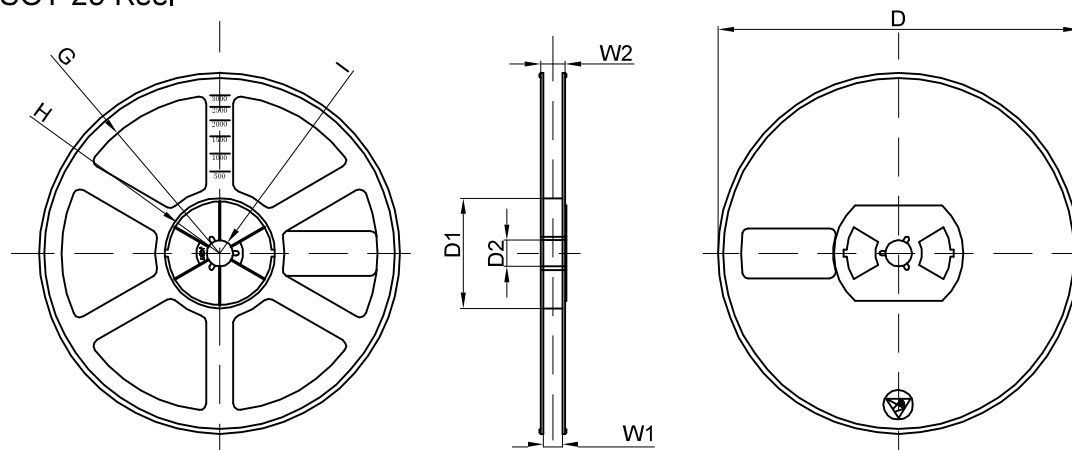

Dimensions are in millimeter								
Reel Option	D	D1	D2	G	H	I	W1	W2
7" Dia	Ø178.00	54.40	13.00	R78.00	R25.60	R6.50	9.50	12.30

REEL	Reel Size	Box	Box Size(mm)	Carton	Carton Size(mm)	G.W.(kg)
3000 pcs	7 inch	30,000 pcs	203×203×195	120,000 pcs	438×438×220	