

SMA Plastic-Encapsulate Diodes

Schottky Rectifier Diodes

Features:

- $I_{F(AV)}$ 2A
- V_{RRM} 20V-200V
- High surge current capability
- Polarity: Color band denotes cathode

Applications:

- Rectifier

Marking

- SS2X
X : From 2 To 20
- SK2X
X : From 2 To 20

SMA



Limiting Values(Absolute Maximum Rating)

Item	Symbol	Unit	Test Conditions	SK2									
				2A	3A	4A	5A	6A	8A	10A	15A	20A	
Repetitive Peak Reverse Voltage	V_{RRM}	V		20	30	40	50	60	80	100	150	200	
Maximum RMS Voltage	V_{RMS}	V		14	21	28	35	42	56	70	105	140	
Average Forward Current	$I_{F(AV)}$	A	60Hz Half-sine wave , Resistance load , $T_a=100^{\circ}C$	2.0									
Surge(Non-repetitive)Forward Current	I_{FSM}	A	60Hz Half-sine wave , 1 cycle , $T_a=25^{\circ}C$	60									
Junction Temperature	T_J	$^{\circ}C$		-55~+150									
Storage Temperature	T_{STG}	$^{\circ}C$		-55 ~+150									

Electrical Characteristics ($T = 25^{\circ}C$ Unless otherwise specified)

Item	Symbol	Unit	Test Condition	SK2									
				2A	3A	4A	5A	6A	8A	10A	15A	20A	
Peak Forward Voltage	V_F	V	$I_F=2.0A$	0.55		0.65		0.85		0.95			
Peak Reverse Current	I_{RRM1}	mA	$V_{RM}=V_{RRM}$	$T_a = 25^{\circ}C$		0.2		0.1					
	I_{RRM2}			$T_a = 100^{\circ}C$		10		5.0					
Thermal Resistance(Typical)	$R_{\theta J-A}$	$^{\circ}C/W$	Between junction and ambient	75									
	$R_{\theta J-L}$		Between junction and terminal	17									

Notes:

Thermal resistance from junction to ambient and from junction to lead mounted on P.C.B. with 0.2" x 0.2" (5.0 mm x 5.0 mm) copper pad areas

Typical Characteristics

FIG.1: FORWARD CURRENT DERATING CURVE

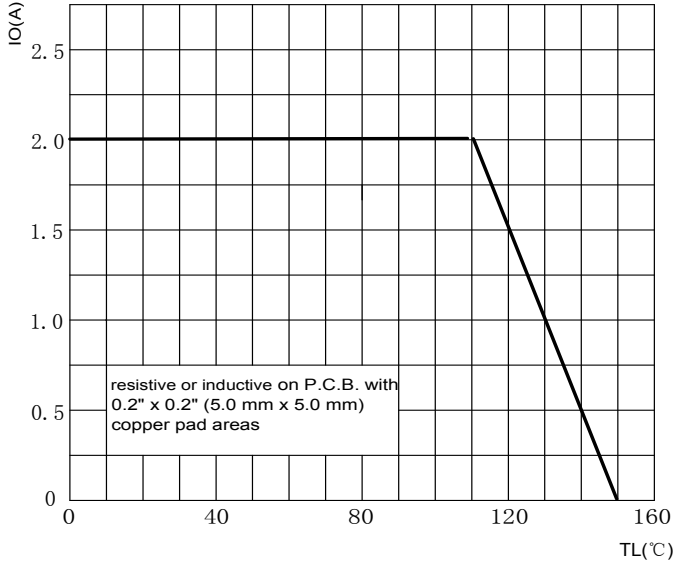

FIG.2: MAXIMUM NON-REPETITIVE FORWARD SURGE CURRENT

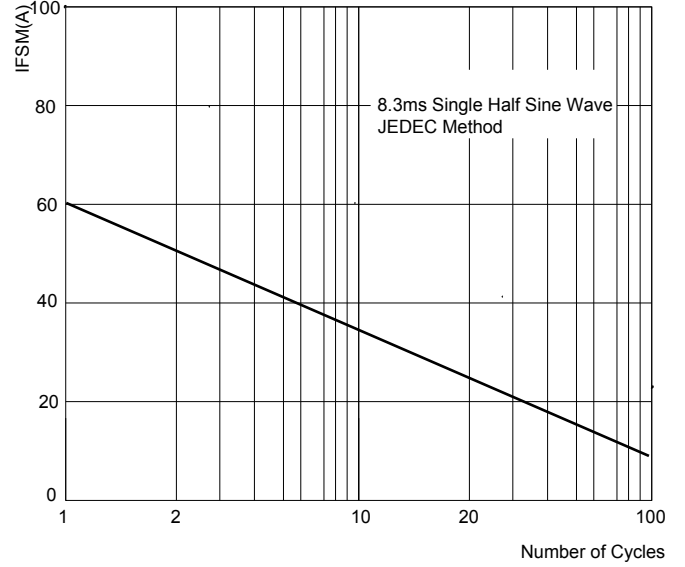

FIG.3: TYPICAL FORWARD CHARACTERISTICS

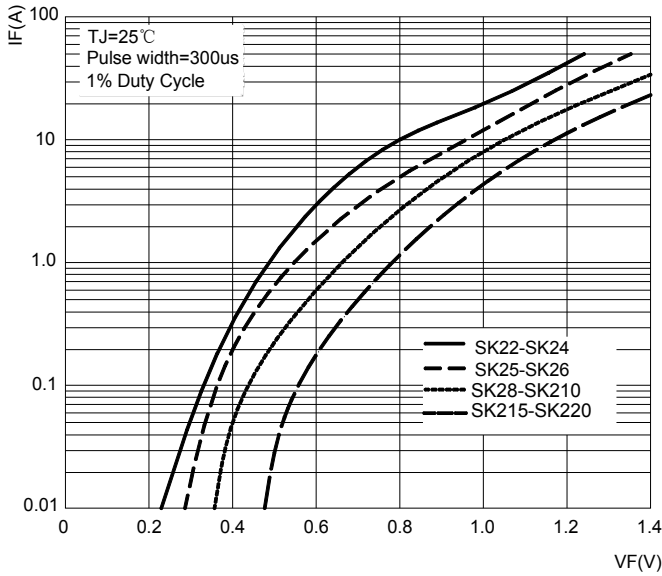
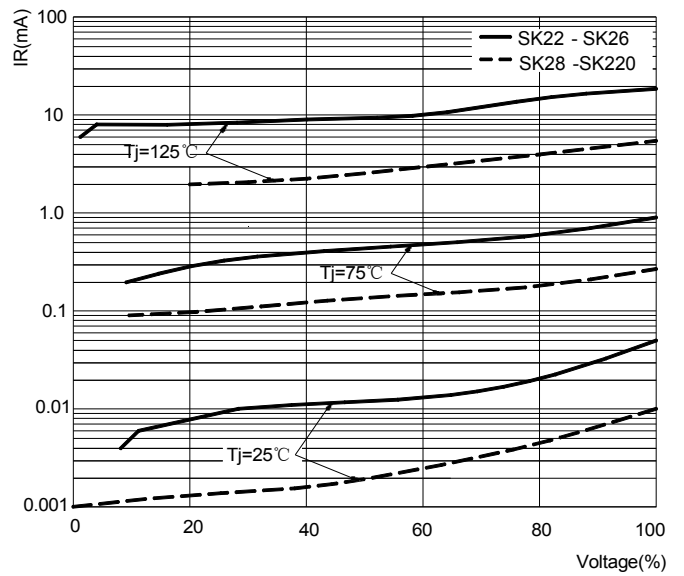
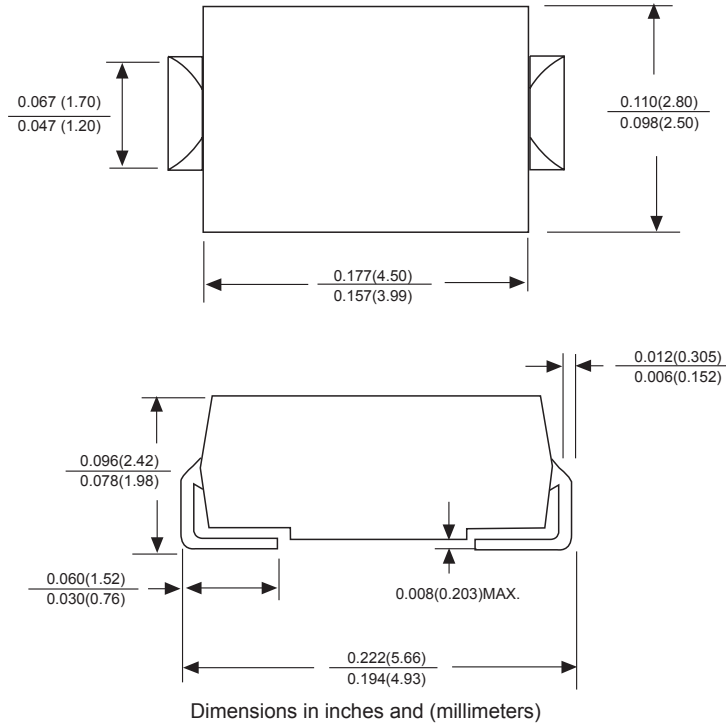

FIG.4: TYPICAL REVERSE CHARACTERISTICS



SMA Package Outline Dimensions



SMA Suggested Pad Layout

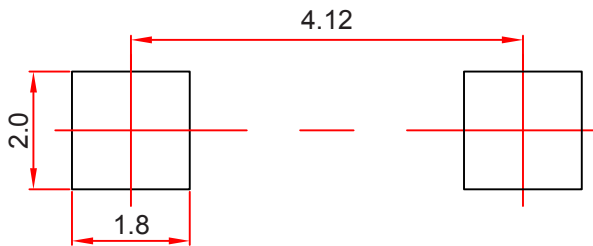

Note:

1. Controlling dimension: in millimeters.
2. General tolerance: $\pm 0.05\text{mm}$.
3. The pad layout is for reference purposes only.

Reel Taping Specifications For Surface Mount Devices-SMA

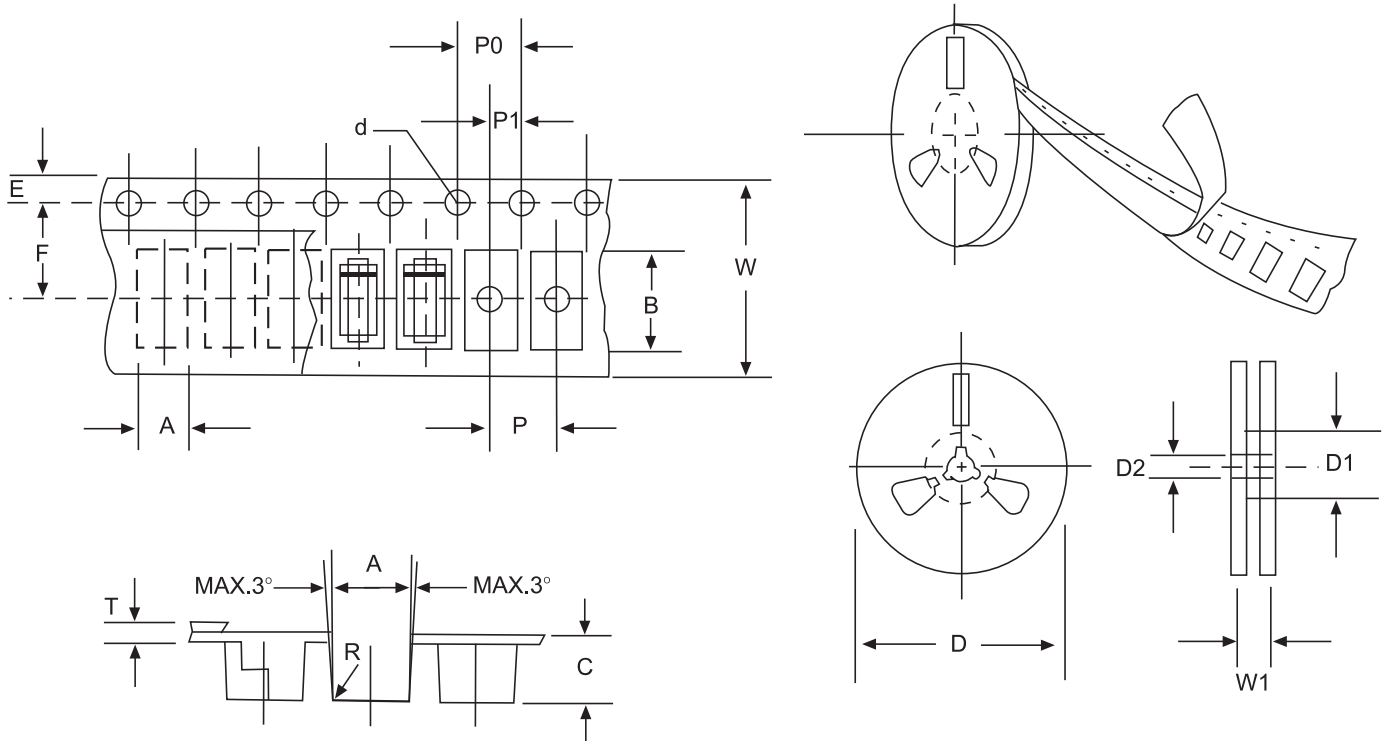

FIG: CONFIGURATION OF SURFACE MOUNTED DEVICES TAPING

ITEM	SYMBOL	SMA mm(inch)
Carrier width	A	2.79±0.1(0.110±0.004)
Carrier length	B	5.33±0.1(0.210±0.004)
Carrier depth	C	2.36±0.1(0.093±0.004)
Sprocket hole	d	1.55±0.05(0.061±0.002)
Reel outside diameter	D	279±2.0 (11± 0.079)
Reel inner diameter	D1	75±1.0 (2.95 ±0.039)
Feed hole diameter	D2	13±0.5(0.512±0.020)
Strocket hole position	E	1.75±0.1(0.069±0.004)
Punch hole position	F	5.5±0.05(0.217±0.002)
Punch hole pitch	P	4.0±0.1(0.157±0.004)
Sprocket hole pitch	P0	4.0±0.1(0.157±0.004)
Embossment center	P1	2.0±0.1(0.079±0.004)
Total tape thickness	T	0.28±0.02(0.011 ±0.0008)
Tape width	W	12.0±0.2(0.472±0.008)
Reel width	W1	16.8±2.0(0.661±0.079)

NOTE: Devices are packed in accordance with EIA standard RS-481-A and specification given above.