

TO-252-2 Silicon Carbide Schottky Diode

SiC Diode 650 V, 10 A, 38nC

Features

- Zero forward recovery voltage
- Zero reverse recovery current
- Excellent surge current capability
- Temperature independent switching
- Positive temperature coefficient on V_F
- High frequency operation

Package: TO-252-2

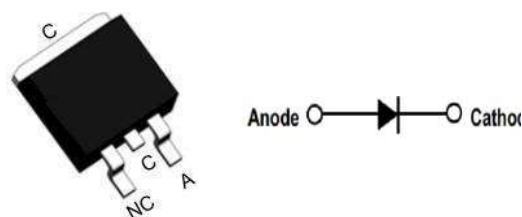

Benefits

- Increased Power Density
- Essentially no Switching Losses
- Reduction of Heat Sink Requirements
- Higher Efficiency
- Reduced EMI

Part NO.	KJSC65C10T2
V_{RRM}	= 650 V
$I_F(T_C=160^\circ\text{C})$	= 10A
Q_C	= 38nC

Applications

- Uninterruptible power supplies
- Switch mode power supplies (SMPS)
- Power Factor Correction
- Motor Drivers

Typical Characteristics

Maximum ratings ($T_j=25^\circ\text{C}$ unless otherwise specified)

Symbol	Parameter	Test conditions	Value	Unit
V_{RRM}	Repetitive peak reverse voltage		650	V
I_F	Continuous forward current	$T_c=25^\circ\text{C}$ $T_c=160^\circ\text{C}$	50 10	A
I_{FSM}	Non-Repetitive forward surge current	$T_c=25^\circ\text{C}$, $t_p=10\text{ms}$, Half Sine Wave	85	A
$\int i^2 dt$	i^2t value	$T_c=25^\circ\text{C}$, $t_p=10\text{ms}$	36	A^2S
P_{tot}	Power dissipation	$T_c=25^\circ\text{C}$ $T_c=110^\circ\text{C}$	197 85	W
T_j	Operating junction temperature		-55~175	$^\circ\text{C}$
T_{stg}	Storage temperature		-55~175	$^\circ\text{C}$

Electrical Characteristics

Static Characteristics

Symbol	Parameter	Test conditions	Value			Unit
			Min.	Typ.	Max.	
V_{DC}	DC blocking voltage	$T_j=25^\circ\text{C}$	650			V
V_F	Diode forward voltage	$I_F=10\text{A}, T_j=25^\circ\text{C}$ $I_F=10\text{A}, T_j=175^\circ\text{C}$		1.29 1.43		V
I_R	Reverse current	$V_R=650\text{V}, T_j=25^\circ\text{C}$ $V_R=650\text{V}, T_j=175^\circ\text{C}$		1 9		μA

Typical Characteristics

AC Characteristics

Symbol	Parameter	Test conditions	Value			Unit
			Min.	Typ.	Max.	
Q _C	Total capacitive charge	V _R =400V , T _j =25°C Q _C = ∫ ₀ ^V R C(V)dV		38		nC
C	Total capacitance	V _R =1V f=1MHz V _R =300V f=1MHz V _R =600V f=1MHz		551 63 57		pF
E _C	Capacitance stored energy	V _R =400V		5.7		μJ

Thermal Characteristics

Symbol	Parameter	Value			Unit
		Min.	Typ.	Max.	
R _{th(jc)}	Thermal Resistance from Junction to Case		0.76		° C/W

Typical Characteristics

Typical Performance

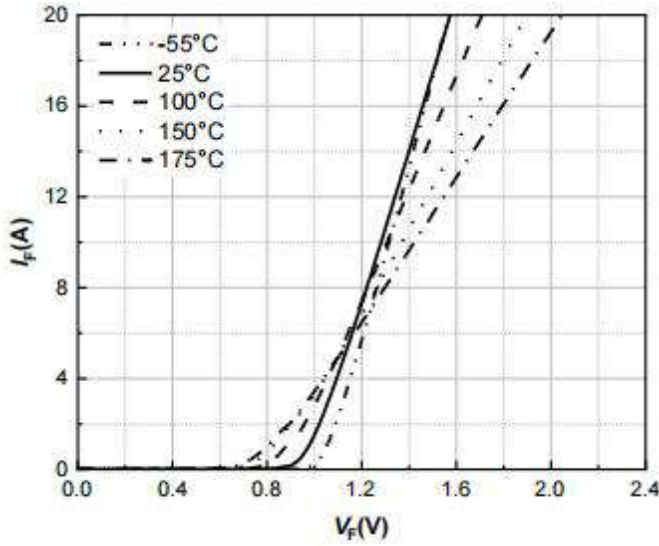

Figure 1. Typical forward characteristics

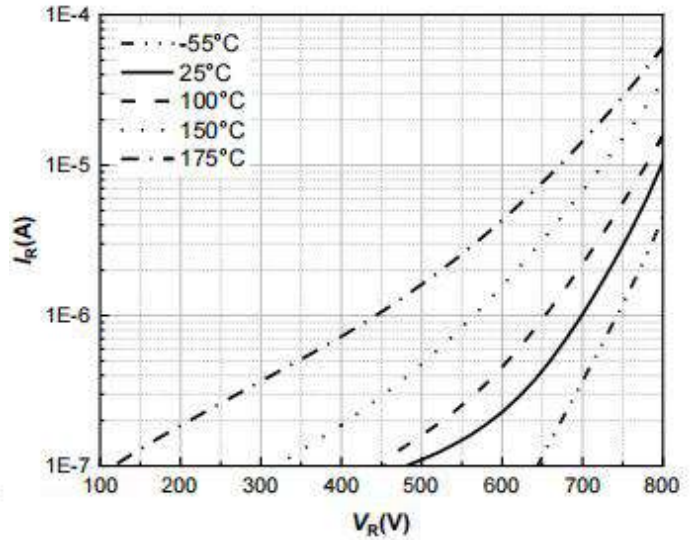

Figure 2. Typical reverse current as function of reverse voltage

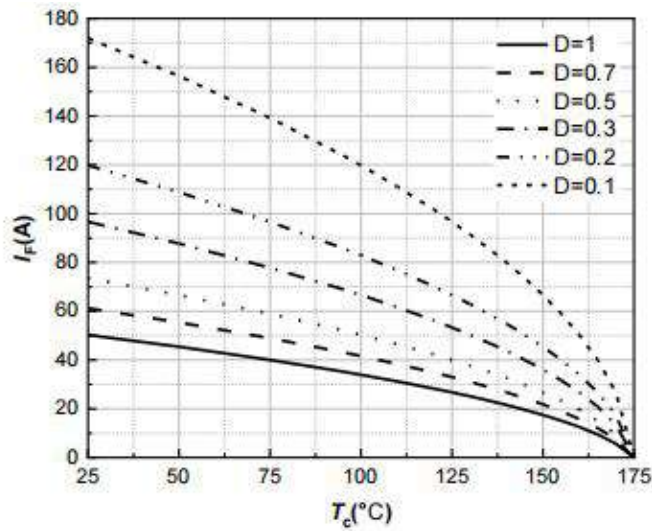

Figure 3. Diode forward current as function of temperature, D=duty cycle

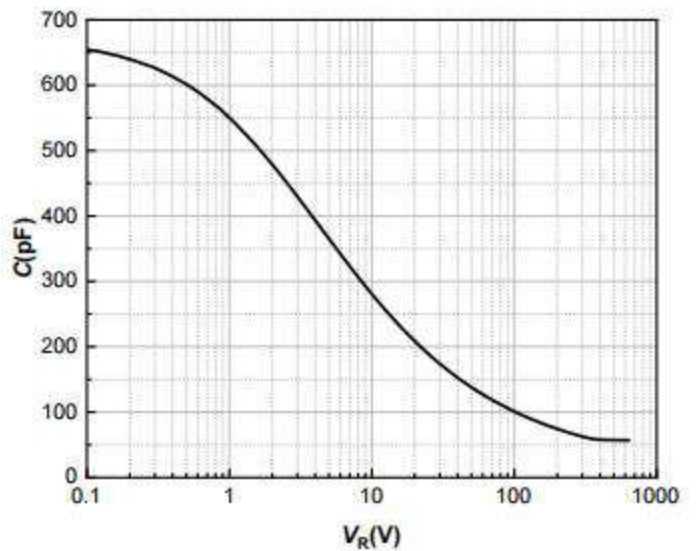

Figure 4. Typical capacitance as function of reverse voltage, $C=f(V_R)$; $T_j=25^\circ\text{C}$; $f=1\text{ MHz}$

Typical Characteristics

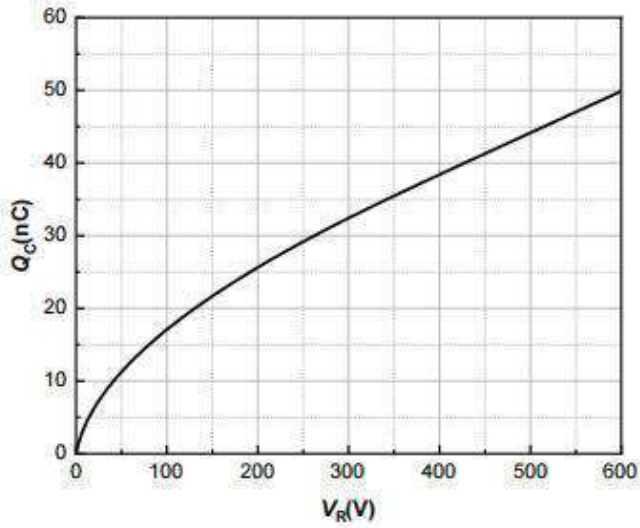

Figure 5. Typical reverse charge as function of reverse voltage

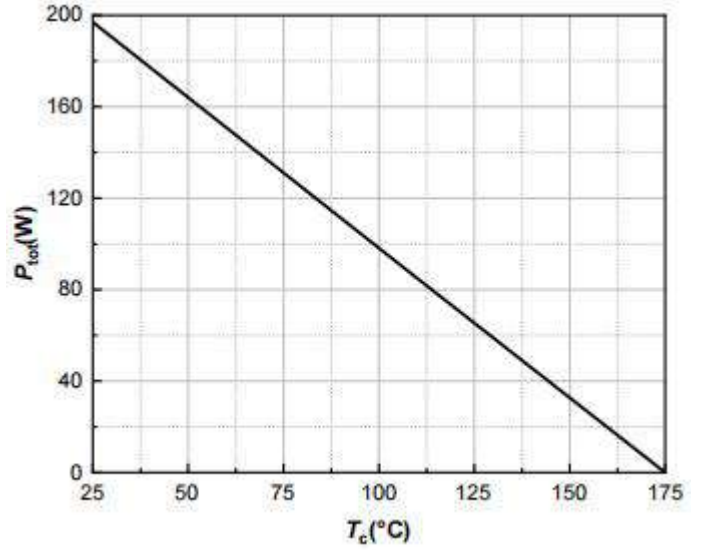

Figure 6. Power dissipation as function of case temperature

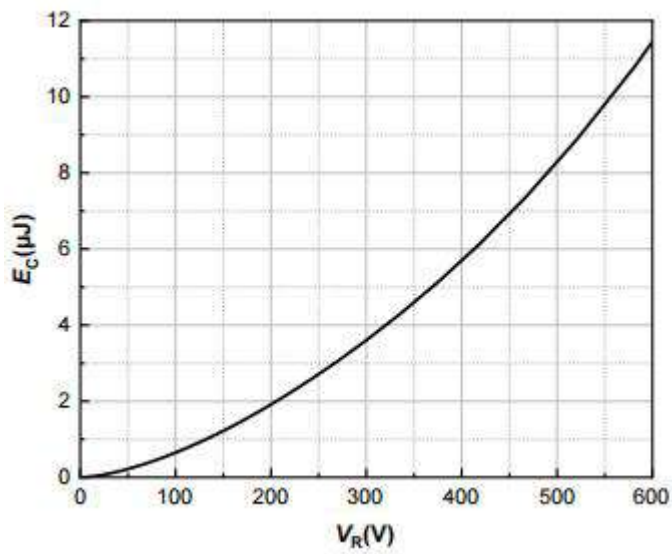

Figure 7. Capacitance stored energy

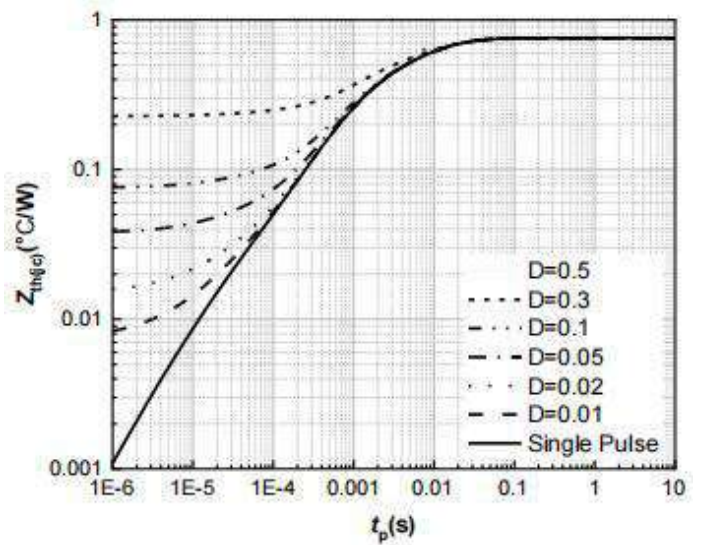
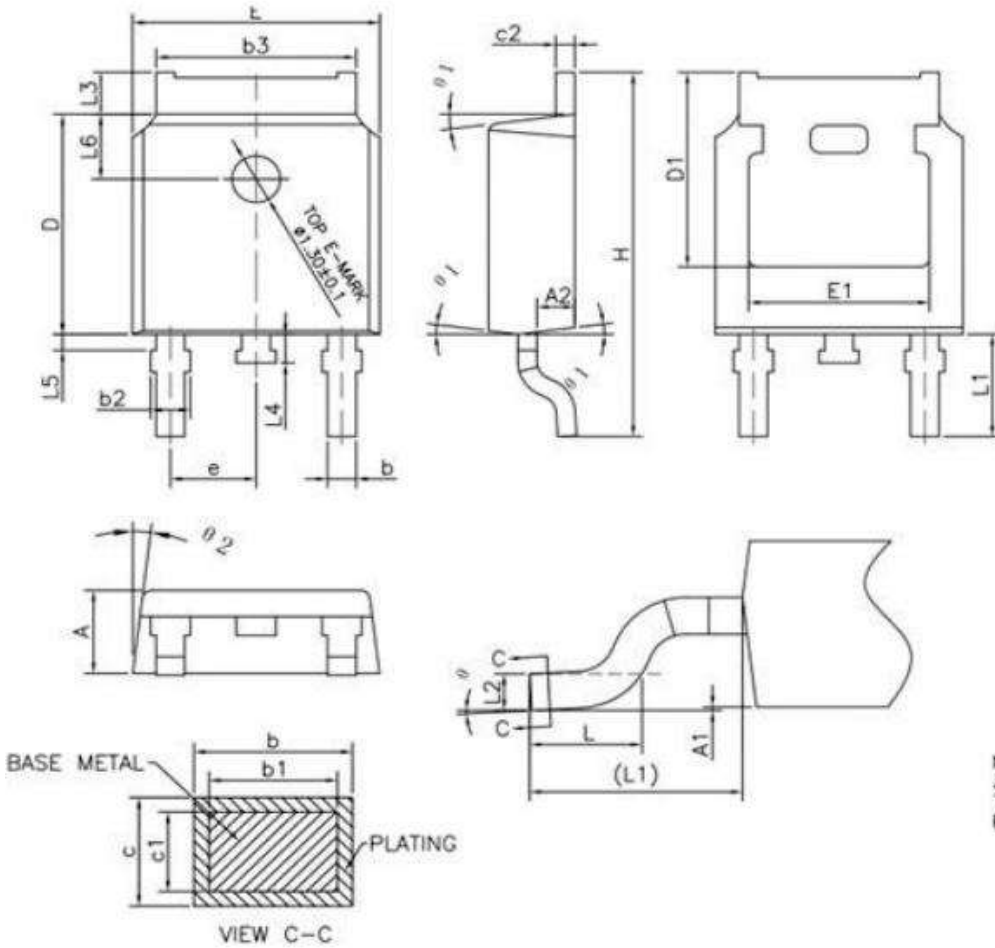

Figure 8. Max. transient thermal impedance, $Z_{th(jc)}=f(t_p)$, parameter: $D=t_p/T$

Package Outline Dimensions



COMMON DIMENSIONS
 (UNITS OF MEASURE =MILLIMETER)

SYMBOL	MIN	NOM	MAX
A	2.20	2.30	2.38
A1	0	---	0.10
A2	0.90	1.01	1.10
b	0.72	---	0.85
b1	0.71	0.76	0.81
b2	0.72	---	0.90
b3	5.13	5.33	5.46
c	0.47	---	0.60
c1	0.46	0.51	0.56
c2	0.47	---	0.60
D	6.00	6.10	6.20
D1	5.25	---	---
E	6.50	6.60	6.70
E1	4.70	---	---
e	2.186	2.286	2.386
H	9.80	10.10	10.40
L	1.40	1.50	1.70
L1	2.90 REF		
L2	0.508 BSC		
L3	0.90	---	1.25
L4	0.60	0.80	1.00
L5	0.15	---	0.75
L6	1.80 REF		
θ	0°	---	8°
θ1	5°	7°	9°
θ2	5°	7°	9°

NOTES:
 ALL DIMENSIONS REFER TO JEDEC STANDARED TO-252 AA DO NOT INCLUDE MOLD FLASH OR PROTRUSIONS