

P-Channel High Density Trench MOSFET

Features:

- Super high dense cell trench design for low $R_{DS(on)}$.
- Rugged and reliable.
- Surface Mount package.

SOT-23

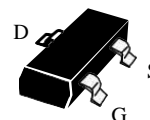

PRODUCT SUMMARY

V_{DSS}	I_D	$R_{DS(on)}$ (m Ω) Max
-30V	- 3.7A	70 @ $V_{GS} = -10V$
	- 3.0A	95 @ $V_{GS} = -4.5V$

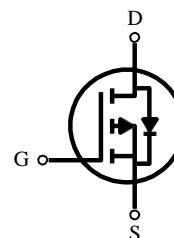

DEVICE MARKING

K3407S = 5BV / A7TA $\frac{X}{X}$	XX:Week Code
-----------------------------------	--------------

ABSOLUTE MAXIMUM RATINGS ($T_A = 25^\circ\text{C}$ unless otherwise noted)

Parameter	Symbol	Limit	Unit
Drain-Source Voltage	V_{DS}	- 30	V
Gate-Source Voltage	V_{GS}	± 20	V
Drain Current-Continuous ^a @ $T_A = 25^\circ\text{C}$ -Pulse ^b	I_D	- 3.7	A
	I_{DM}	- 14	A
Drain-Source Diode Forward Current ^a	I_S	- 1.9	A
Maximum Power Dissipation ^a	P_D	$T_A = 25^\circ\text{C}$	1.25
		$T_A = 75^\circ\text{C}$	0.75
Operating Junction and Storage Temperature Range	T_J, T_{STG}	- 55 to 150	$^\circ\text{C}$

THERMAL CHARACTERISTICS

Thermal Resistance, Junction-to-Ambient ^a	R_{thJA}	100	$^\circ\text{C/W}$
------------------------------------------------------	------------	-----	--------------------

Note :

a. Surface Mounted on FR4 Board , $t \leq 5\text{sec}$.

b. Pulse width limited by maximum junction temperature .

ELECTRICAL CHARACTERISTICS (TA=25°C unless otherwise noted)

Parameter	Symbol	Condition	Min	Typ ^c	Max	Unit	
OFF CHARACTERISTICS							
Drain-Source Breakdown Voltage	BV _{DSS}	V _{GS} = 0V , I _D = -250uA	-30			V	
Zero Gate Voltage Drain Current	I _{DSS}	V _{DS} = -24V , V _{GS} = 0V			-1	uA	
Gate-Body Leakage	I _{GSS}	V _{GS} = -20V , V _{DS} = 0V			-100	nA	
ON CHARACTERISTICS^b							
Gate Threshold Voltage	V _{GS(th)}	V _{DS} = V _{GS} , I _D = -250uA	-1	-1.5	-3	V	
Drain-Source On-State Resistance	R _{DS(on)}	V _{GS} = -10V , I _D = -3.7A		56	70	mΩ	
		V _{GS} = -4.5V , I _D = -3.0A		73	95		
Forward Transconductance	g _{fs}	V _{DS} = -15V , I _D = -3.5A		10.2		S	
DRAIN-SOURCE DIODE CHARACTERISTICS^b							
Diode Forward Voltage	V _{SD}	V _{GS} = 0V , I _S = -1.9A			-1.3	V	
DYNAMIC CHARACTERISTICS^c							
Input Capacitance	C _{ISS}	V _{DS} = -15V , V _{GS} = 0V f = 1.0MHz		490		pF	
Output Capacitance	C _{OSS}				66		pF
Reverse Transfer Capacitance	C _{RSS}				53		pF
SWITCHING CHARACTERISTICS^c							
Turn-On Delay Time	t _{D(ON)}	V _{DD} = -15V , I _D = -1A		4.4		ns	
Rise Time	t _r	V _{GEN} = -10V		2.2		ns	
Turn-Off Delay Time	t _{D(OFF)}	R _L = 15 Ω		22		ns	
Fall Time	t _f	R _{GEN} = 6 Ω		4.2		ns	
Total Gate Charge	Q _g	V _{DS} = -15V		10		nC	
Gate-Source Charge	Q _{gs}	I _D = -1A		1.5		nC	
Gate-Drain Charge	Q _{gd}	V _{GS} = -10V		1.4		nC	

Note :

b. Pulse Test : Pulse width ≤ 300us , Duty Cycle ≤ 2% .

c. Guaranteed by design , not subject to production testing .

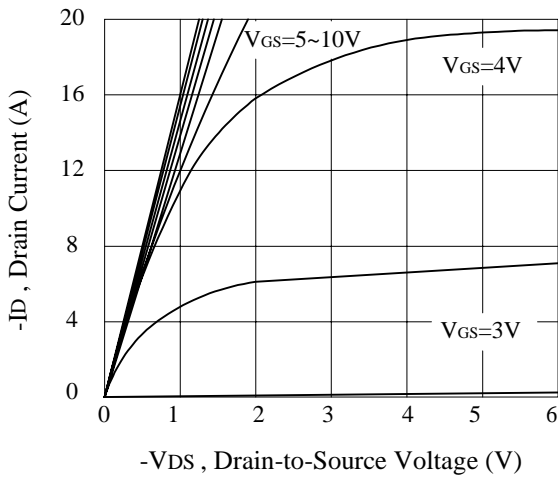

Figure 1. Output Characteristics

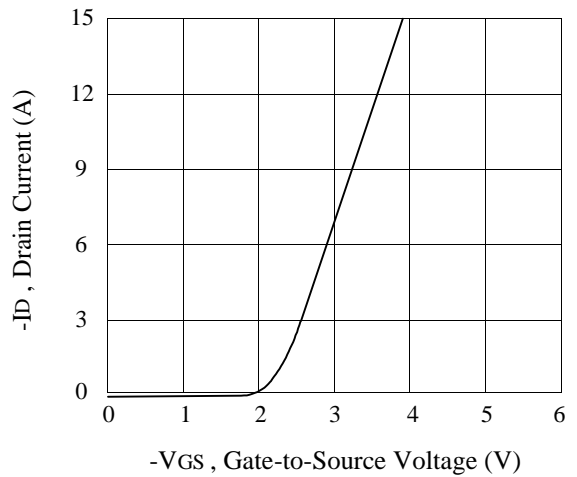

Figure 2. Transfer Characteristics

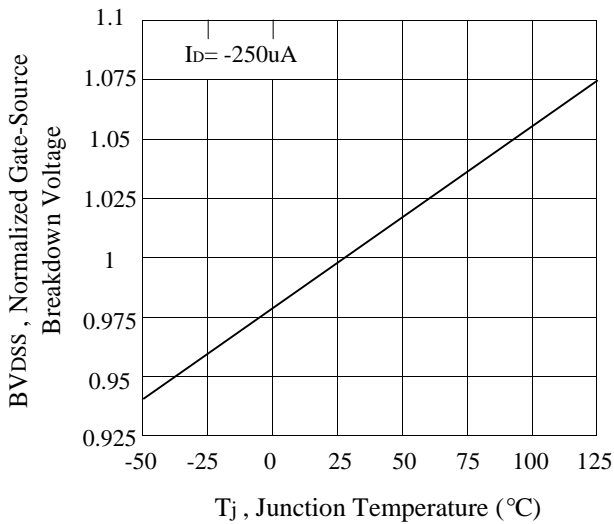

Figure 3. Breakdown Voltage Variation with Temperature

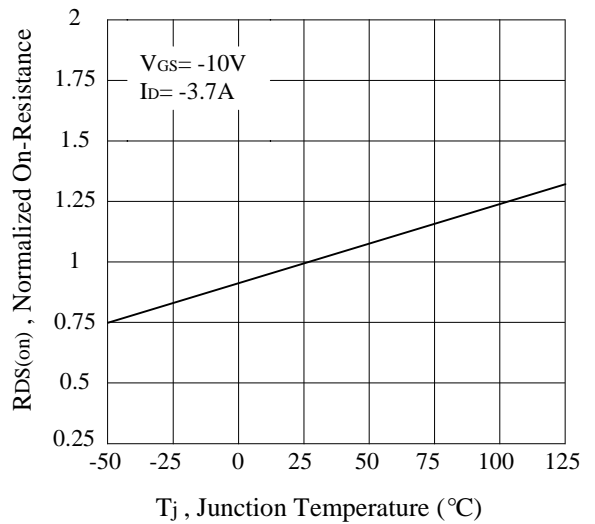

Figure 4. On-Resistance Variation with Temperature

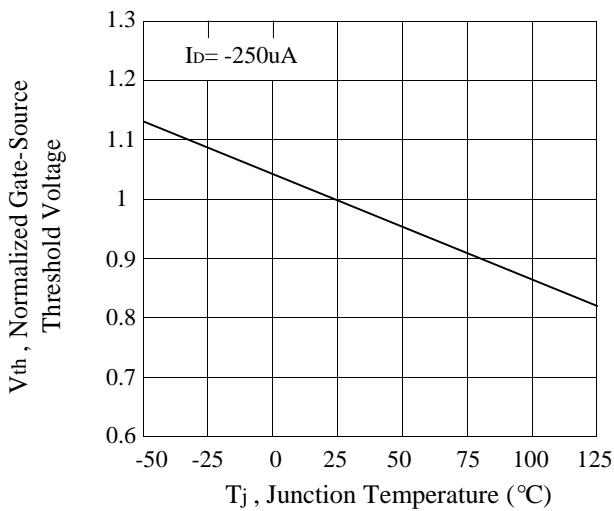

Figure 5. Gate Threshold Variation with Temperature

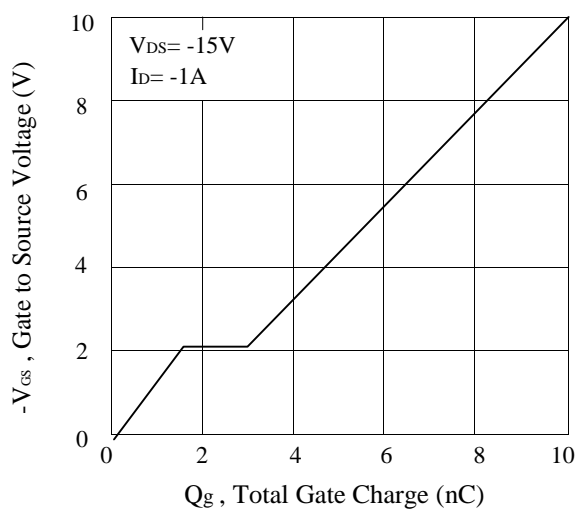
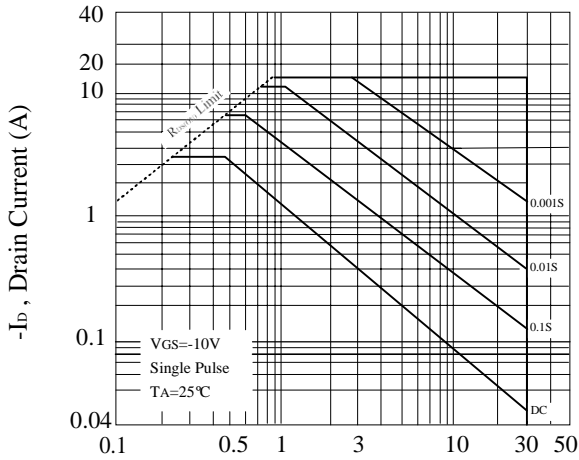
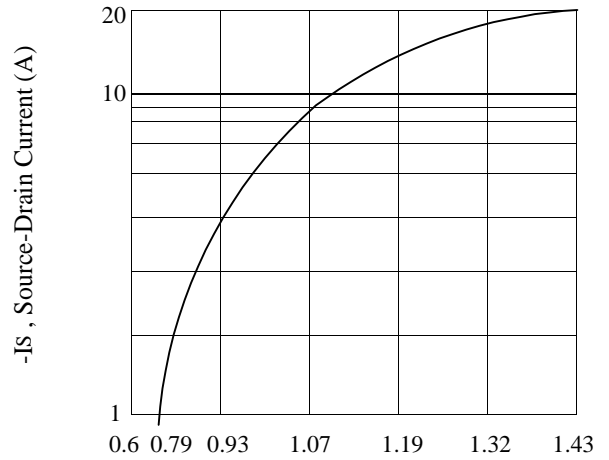

Figure 6. Gate Charge



-V_{DS}, Drain-Source Voltage (V)
 Figure 7. Maximum Safe Operating Area



-V_{SD}, Body Diode Forward Voltage (V)
 Figure 1. Body Diode Forward Voltage Variation with Source Current

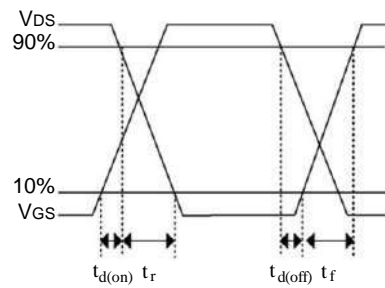
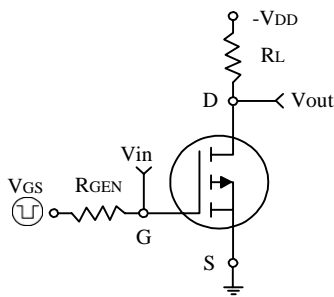

Figure 9. Switching Test Circuit and Switching Waveforms

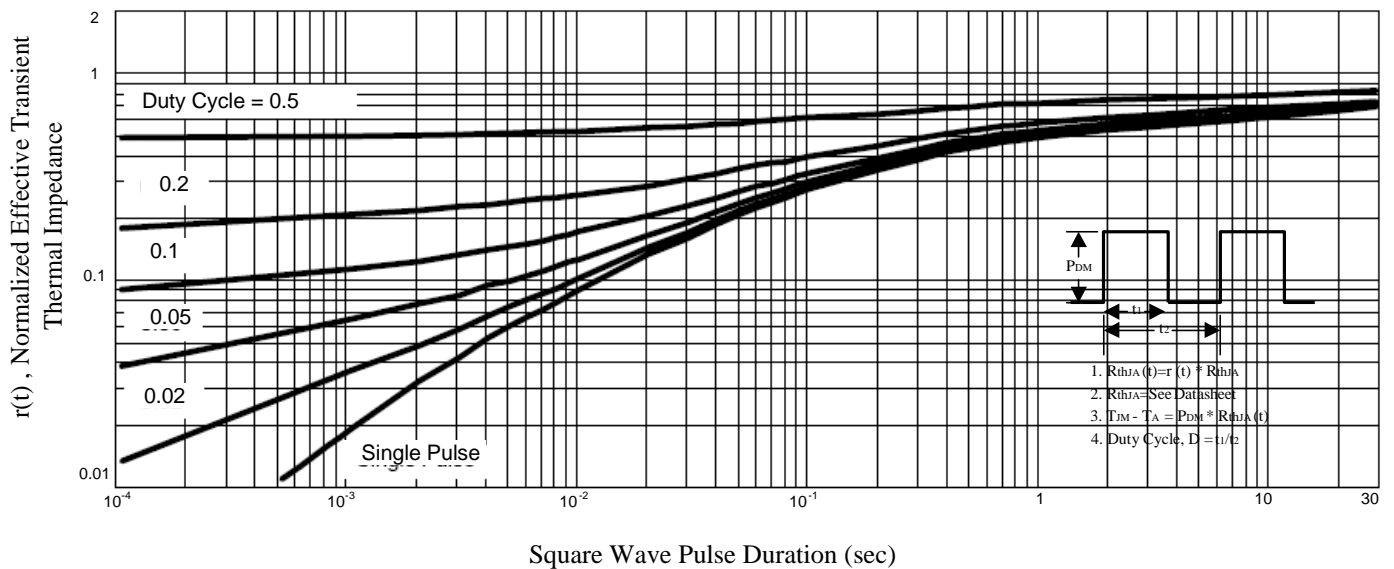
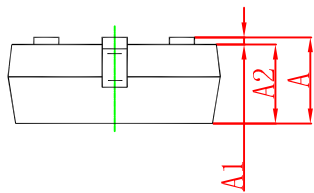
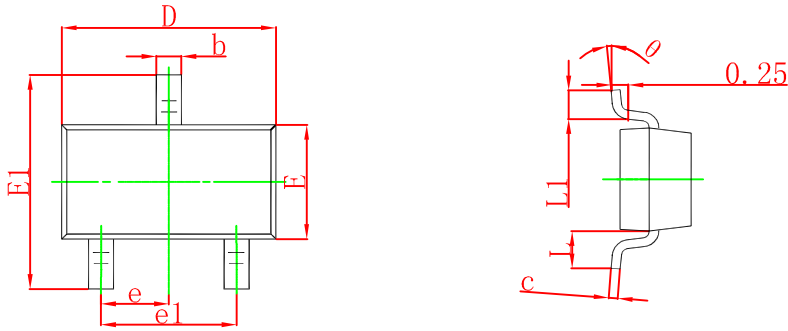

Figure 10. Normalized Thermal Transient Impedance Curve

SOT-23 Package Outline Dimensions



Symbol	Dimensions In Millimeters		Dimensions In Inches	
	Min	Max	Min	Max
A	0.900	1.150	0.035	0.045
A1	0.000	0.100	0.000	0.004
A2	0.900	1.050	0.035	0.041
b	0.300	0.500	0.012	0.020
c	0.080	0.150	0.003	0.006
D	2.800	3.000	0.110	0.118
E	1.200	1.400	0.047	0.055
E1	2.250	2.550	0.089	0.100
e	0.950 TYP		0.037 TYP	
e1	1.800	2.000	0.071	0.079
L	0.550 REF		0.022 REF	
L1	0.300	0.500	0.012	0.020
θ	0°	8°	0°	8°

SOT-23 Suggested Pad Layout

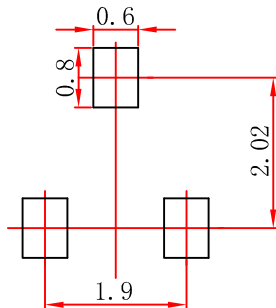

- Note:
1. Controlling dimension: in millimeters.
 2. General tolerance: $\pm 0.05\text{mm}$.
 3. The pad layout is for reference purposes only.

SOT-23 Tape and Reel

SOT-23 Embossed Carrier Tape

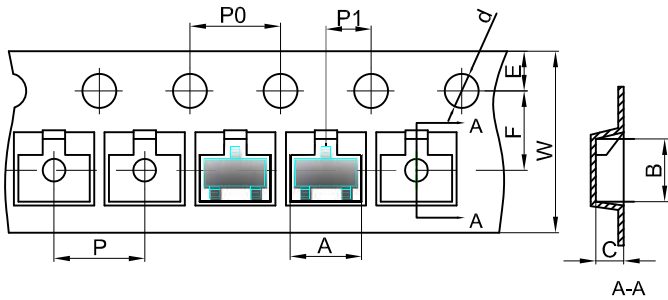

Packaging Description:

SOT-23 parts are shipped in tape. The carrier tape is made from a dissipative (carbon filled) polycarbonate resin. The cover tape is a multilayer film (Heat Activated Adhesive in nature) primarily composed of polyester film, adhesive layer, sealant, and anti-static sprayed agent. These reeled parts in standard option are shipped with 3,000 units per 7" or 17.8cm diameter reel. The reels are clear in color and is made of polystyrene plastic (anti-static coated).

Dimensions are in millimeter										
Pkg type	A	B	C	d	E	F	P0	P	P1	W
SOT-23	3.15	2.77	1.22	Ø1.50	1.75	3.50	4.00	4.00	2.00	8.00

SOT-23 Tape Leader and Trailer

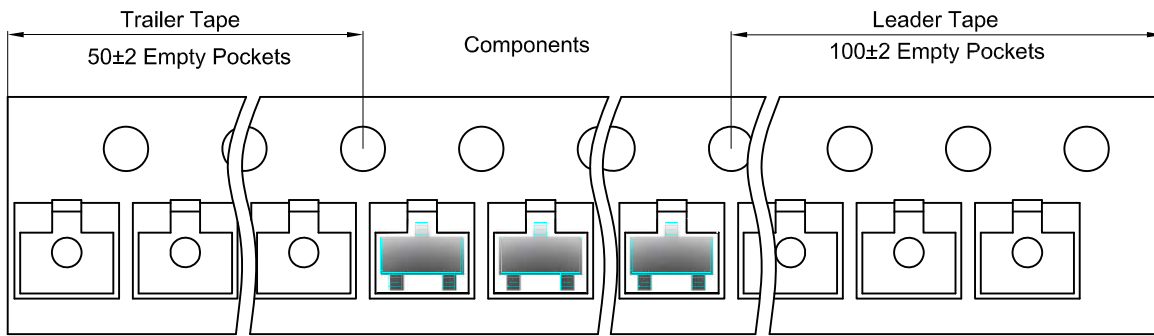

SOT-23 Reel

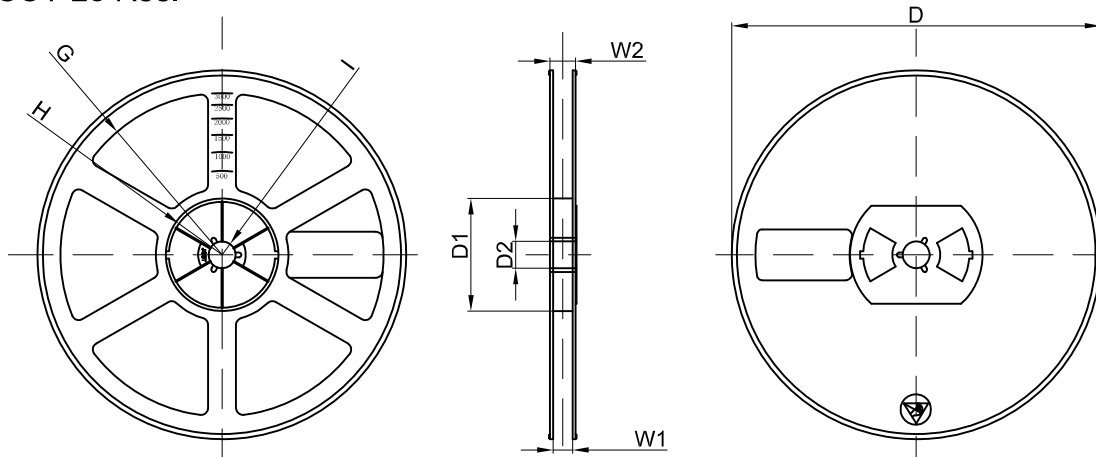

Dimensions are in millimeter								
Reel Option	D	D1	D2	G	H	I	W1	W2
7"Dia	Ø178.00	54.40	13.00	R78.00	R25.60	R6.50	9.50	12.30

REEL	Reel Size	Box	Box Size(mm)	Carton	Carton Size(mm)	G.W.(kg)
3000 pcs	7 inch	45,000 pcs	203×203×195	180,000 pcs	438×438×220	