

AUTOMOTIVE SCHOTTKY BARRIER RECTIFIER

Features:

- Plastic package has Underwriters Laboratory Flammability Classification 94V-0
- Metal silicon junction ,majority carrier conduction
- Guard ring for overvoltage protection
- Low power loss ,high efficiency
- High current capability ,low forward voltage drop
- High surge capability
- High temperature soldering guaranteed:260°C/10 seconds at terminals
- Component in accordance to RoHS 2015/863/EU
- AEC-Q101 qualified and PPAP capable



Mechanical Data:

- Case: SOD-123FL molded plastic body
- Terminals: Solder Plated, solderable per MIL-STD-750,method 2026
- Polarity: Color band denotes cathode end
- Weight: 11.7 mg(approximately)

SOD-123FL



TYPICAL APPLICATIONS

For use in low voltage ,high frequency inverters ,DC/DC converters,
 free wheeling ,and polarity protection applications

MAXIMUM RATINGS

(Ratings at 25°C ambient temperature unless otherwise specified)

Parameter	Symbol	Value	Unit
Maximum repetitive peak reverse voltage	V_{RRM}	60	V
Maximum average forward rectified current	$I_{F(AV)}$	3.0	A
Peak forward surge current 8.3ms single half sine-wave superimposed on rated load (JEDEC method at rated TL)	I_{FSM}	80	A
Operating junction temperature range	T_j	-55 to+150	°C
Storage temperature range	T_{stg}	-55 to+150	°C

Electrical Characteristics (T_a=25°C Unless Otherwise Noted)

Parameter	Test Conditions		Symbol	Typ.	Max.	Unit
Instaneous forward voltage	T _j =25°C	I _f =1.0A	V _F 1)	0.44	-	V
		I _f =3.0A		0.60	0.66	
	T _j =125°C	I _f =1.0A		0.36	-	
		I _f =3.0A		0.53	0.59	
Reverse current	T _j =25°C	V _R =60V	I _R 2)	-	50	μA
	T _j =125°C			-	40	mA
Typical junction capacitance	4V,1MHz		C _J	100		pF

Notes: 1.Pulse test: 300 μs pulse width,1% duty cycle
 2.Pulse test: pulse width≤40ms

THERMAL CHARACTERISTICS

Parameter	Symbol	SMAF	Unit
Typical thermal resistance	R _{θJA} 3) 4)	150	°C/W
	R _{θJM}	15	

3.The heat generated must be less than the thermal conductivity from junction-to-ambient: $dP_j/dT_j < 1/R_{\theta JA}$
 4.Thermal resistance junction-to-ambient to follow JEDEC51-2A, device mounted on FR4 PCB, 2 oz., standard footprint
 5.Thermal resistance junction-to-mount to follow JEDEC51-14 transient dual interface test method (TDIM)

AVAILABALE PACK INFORMATION

Product code	Pack	Reel Size (mm)	Quantity (pcs/reel)	Box Size L×W×H (mm)	Quantity (reel/box)	Carton Size L×W×H (mm)	Quantity (box/carton)
K36-V-SOD-123FL	T/R	Φ330	7500	330×35×333	2	364×364×360	8

RATINGS AND CHARACTERISTICS OF K36-V

FIG.1-FORWARD CURRENT DERATING CURVE

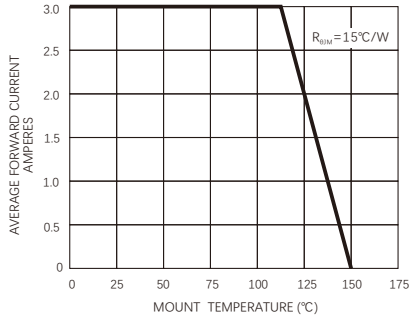

FIG.2-MAXIMUM NON-REPETITIVE PEAK FORWARD SURGE CURRENT

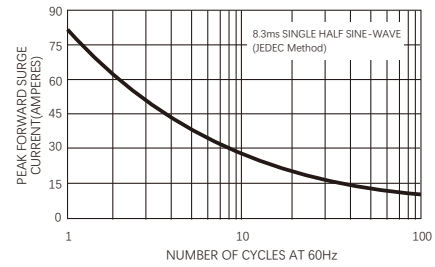

FIG.3-TYPICAL INSTANTANEOUS FORWARD CHARACTERISTICS

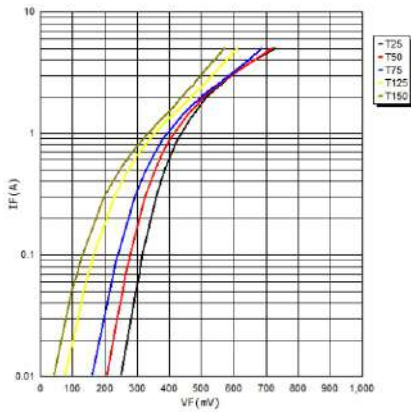

FIG.4-TYPICAL REVERSE CHARACTERISTICS

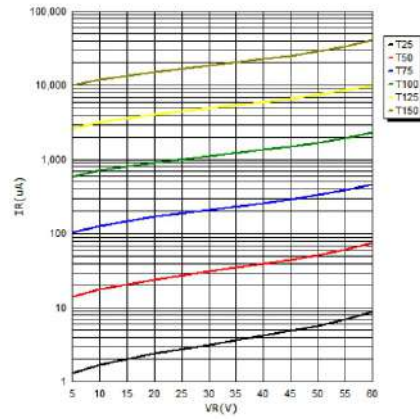
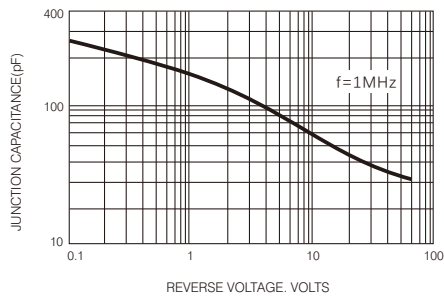
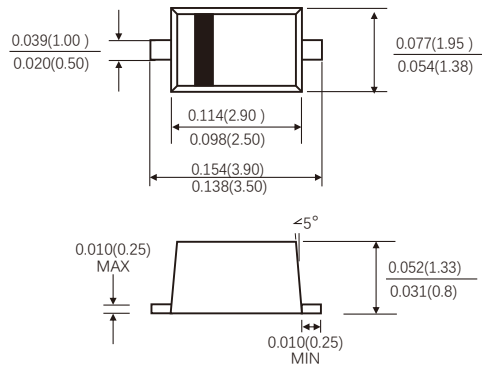

FIG.5-TYPICAL JUNCTION CAPACITANCE



PACKAGE OUTLINE DIMENSIONS

SOD-123FL



Suggested PAD Layout

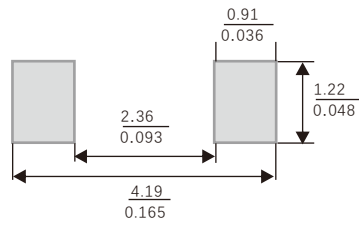

Dimensions in millimeters/inches