

10A 600V N-CHANNEL POWER MOSFET

Description:

The KWNJ10N60 is a high voltage and high current power MOSFET, designed to have better characteristics, such as fast switching time, low gate charge, low on-state resistance and have a high rugged avalanche characteristics. This power MOSFET is usually used at high speed switching applications in power supplies, PWM motor controls, high efficient DC to DC converters and bridge circuits.

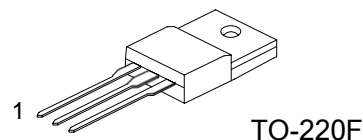
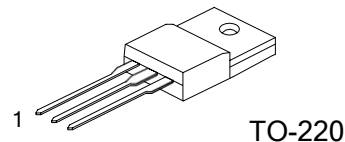

Features:

- * $V_{DS} = 600V$
- * $I_D = 10A$
- * $R_{DS(ON)} = 0.75\Omega @ V_{GS} = 10V$.
- * Low gate charge (typical 44nC)
- * Low CRSS (typical 18 pF)
- * Fast switching capability
- * Avalanche energy specified
- * Improved dv/dt capability

■ SYMBOL

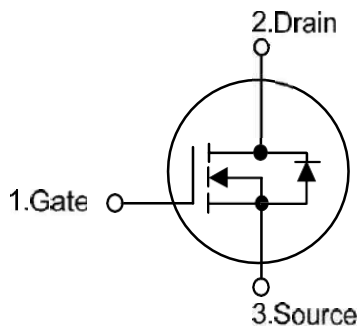

ORDERING INFORMATION

Ordering Number	Package	Pin Assignment			Packing
		1	2	3	
KWNJ10N60	TO-220	G	D	S	Tape Box
KWNJ10N60-BL	TO-220	G	D	S	Bulk
KWNJ10N60F	TO-220F	G	D	S	Tube

Note: Pin Assignment: G: Gate D: Drain S: Source

ABSOLUTE MAXIMUM RATINGS ($T_C=25^{\circ}\text{C}$ unless otherwise specified)

PARAMETER	SYMBOL	RATINGS	UNIT
Drain-Source Voltage	V_{DSS}	600	V
Gate-Source Voltage	V_{GSS}	± 30	V
Avalanche Current (Note 2)	I_{AR}	10	A
Drain Current	Continuous	I_D	10
	Pulsed (Note 2)	I_{DM}	38
Avalanche Energy	Single Pulsed (Note 3)	E_{AS}	700
	Repetitive (Note 2)	E_{AR}	15.6
Peak Diode Recovery dv/dt (Note 4)	dv/dt	4.5	V/ns
Power Dissipation	TO-220	P_D	156
	TO-220F		50
Junction Temperature	T_J	+150	$^{\circ}\text{C}$
Operating Temperature	T_{OPR}	-55 ~ +150	$^{\circ}\text{C}$
Storage Temperature	T_{STG}	-55 ~ +150	$^{\circ}\text{C}$

Notes: 1. Absolute maximum ratings are those values beyond which the device could be permanently damaged.

Absolute maximum ratings are stress ratings only and functional device operation is not implied.

2. Repetitive Rating: Pulse width limited by maximum junction temperature

3. $L = 14.2\text{mH}$, $I_{AS} = 10\text{A}$, $V_{DD} = 50\text{V}$, $R_G = 25\ \Omega$ Starting $T_J = 25^{\circ}\text{C}$

4. $I_{SD} = 9.5\text{A}$, $di/dt = 200\text{A}/3\text{s}$, $V_{DD} = BV_{DSS}$, Starting $T_J = 25^{\circ}\text{C}$

THERMAL DATA

PARAMETER	SYMBOL	RATING	UNIT
Junction to Ambient	θ_{JA}	62.5	$^{\circ}\text{C}/\text{W}$
Junction to Case	TO-220	0.8	$^{\circ}\text{C}/\text{W}$
	TO-220F	2.5	
	θ_{JC}		

ELECTRICAL CHARACTERISTICS (T_C=25°C, unless otherwise specified)

PARAMETER	SYMBOL	TEST CONDITIONS	MIN	TYP	MAX	UNIT
OFF CHARACTERISTICS						
Drain-Source Breakdown Voltage	BV _{DSS}	V _{GS} =0V, I _D =250 μ A	600			V
Drain-Source Leakage Current	I _{DSS}	V _{DS} =600V, V _{GS} =0V			1	μ A
Gate-Source Leakage Current	Forward	V _{GS} =30 V, V _{DS} =0V			100	nA
	Reverse		V _{GS} =-30 V, V _{DS} =0V			-100
Breakdown Voltage Temperature Coefficient	$\frac{\Delta BV_{DSS}}{\Delta T_J}$	I _D =250 μ A, Referenced to 25°C		0.7		V/°C
ON CHARACTERISTICS						
Gate Threshold Voltage	V _{GS(TH)}	V _{DS} =V _{GS} , I _D =250 μ A	2.0		4.0	V
Static Drain-Source On-State Resistance	R _{DS(ON)}	V _{GS} =10V, I _D =5A		0.68	0.75	Ω
DYNAMIC CHARACTERISTICS						
Input Capacitance	C _{ISS}	V _{DS} =25V, V _{GS} =0V, f=1.0 MHz		1570	2040	pF
Output Capacitance	C _{OSS}		166	215	pF	
Reverse Transfer Capacitance	C _{RSS}		18	24	pF	
Gate Resistance	R _G	V _{DS} =0V, V _{GS} =0V, f=1MHz	0.25		1.4	Ω
SWITCHING CHARACTERISTICS						
Turn-On Delay Time	t _{D(ON)}	V _{DD} =300V, I _D =10A, R _G =25 Ω (Note1, 2)		23	55	ns
Turn-On Rise Time	t _r		69	150	ns	
Turn-Off Delay Time	t _{D(OFF)}		144	300	ns	
Turn-Off Fall Time	t _f		77	165	ns	
Total Gate Charge	Q _G	V _{DS} =480V, I _D =10A, V _{GS} =10 V (Note1, 2)		44	57	nC
Gate-Source Charge	Q _{GS}		6.7		nC	
Gate-Drain Charge	Q _{GD}		18.5		nC	
DRAIN-SOURCE DIODE CHARACTERISTICS AND MAXIMUM RATINGS						
Drain-Source Diode Forward Voltage	V _{SD}	V _{GS} =0 V, I _S =10A			1.4	V
Maximum Continuous Drain-Source Diode Forward Current	I _S				10	A
Maximum Pulsed Drain-Source Diode Forward Current	I _{SM}				38	A
Reverse Recovery Time	t _{rr}	V _{GS} =0 V, I _S =10A,		420		ns
Reverse Recovery Charge	Q _{RR}	dI _F /dt=100A/ μ s (Note 1)		4.2		μ C

Notes: 1. Pulse Test : Pulse width \gg 300 μ s, Duty cycle \gg 2%

2. Essentially independent of operating temperature

TEST CIRCUITS AND WAVEFORMS

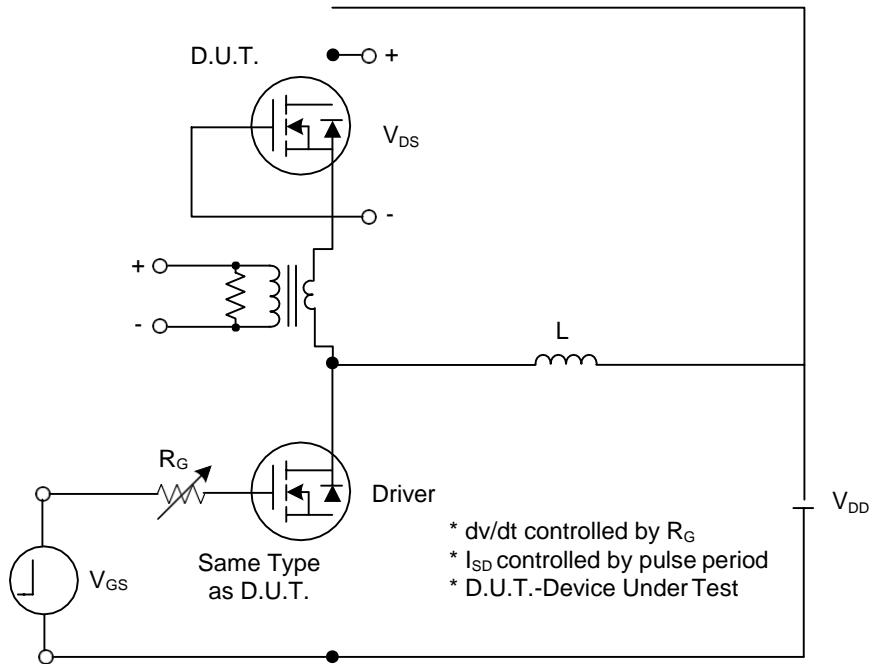

Peak Diode Recovery dv/dt Test Circuit

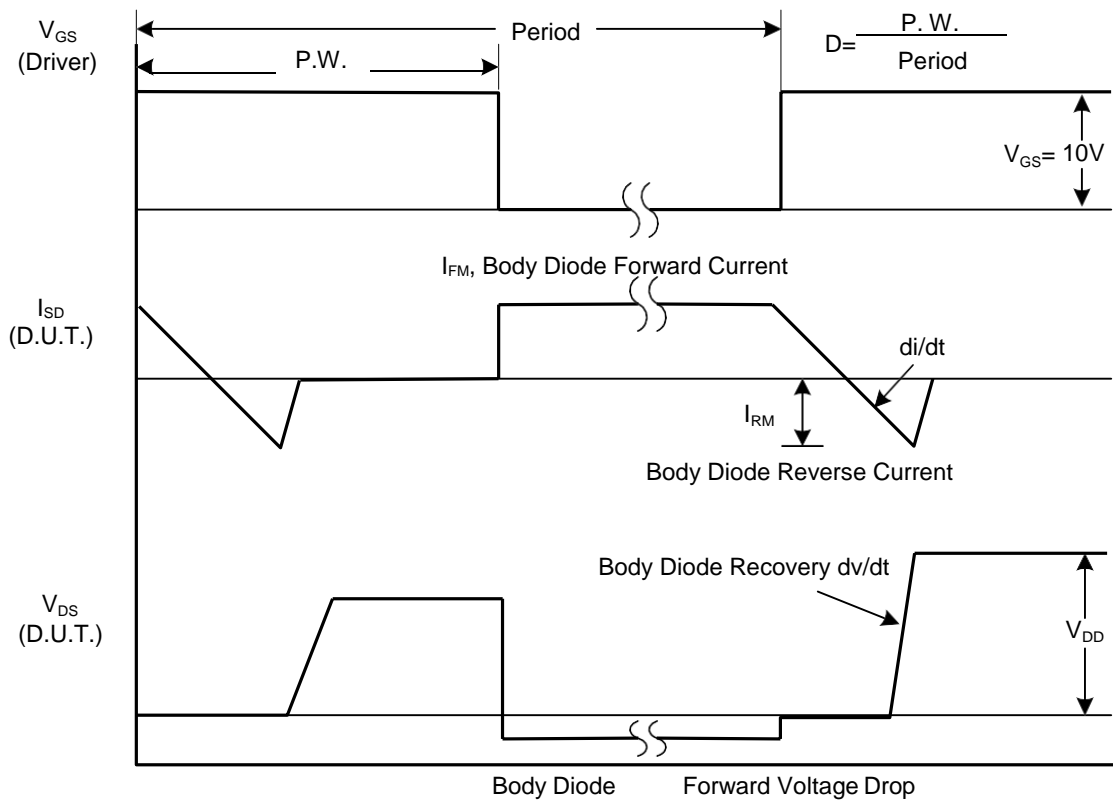

Peak Diode Recovery dv/dt Waveforms

TEST CIRCUITS AND WAVEFORMS(Cont.)

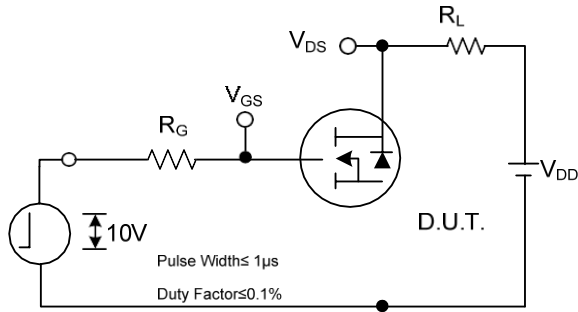

Switching Test Circuit

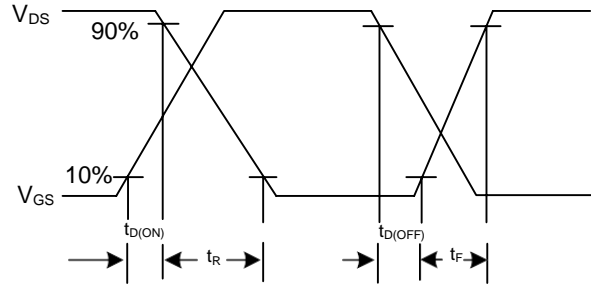

Switching Waveforms

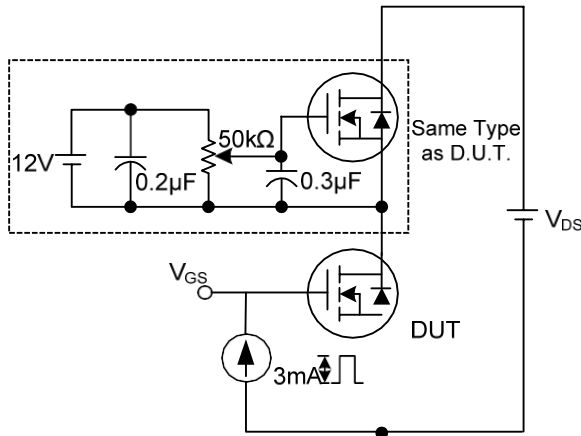

Gate Charge Test Circuit

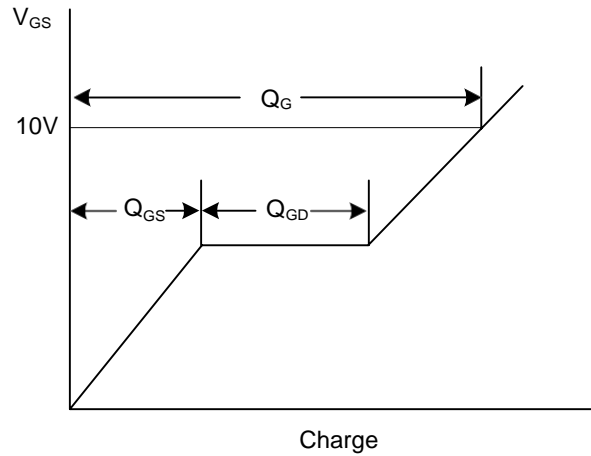

Gate Charge Waveform

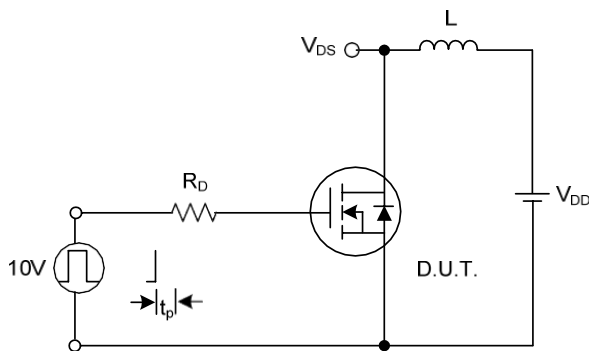

Unclamped Inductive Switching Test Circuit

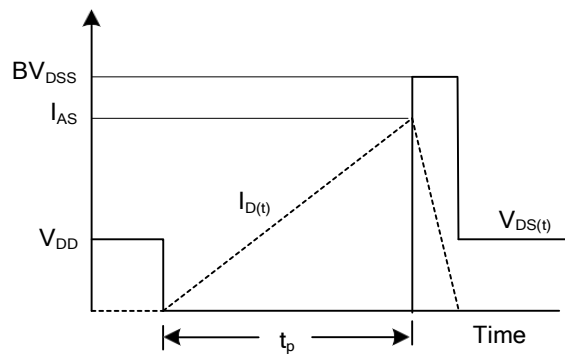

Unclamped Inductive Switching Waveforms

TYPICAL CHARACTERISTICS

On-Region Characteristics

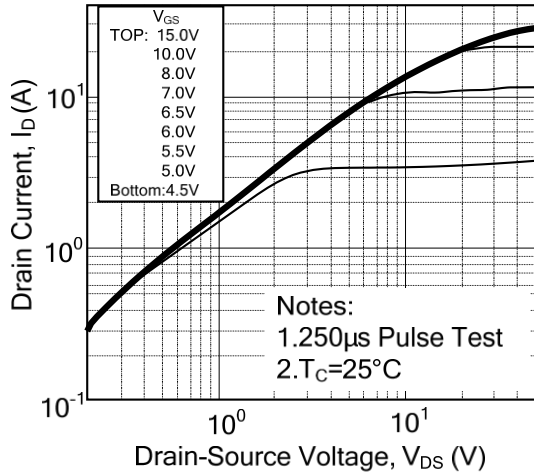

Transfer Characteristics

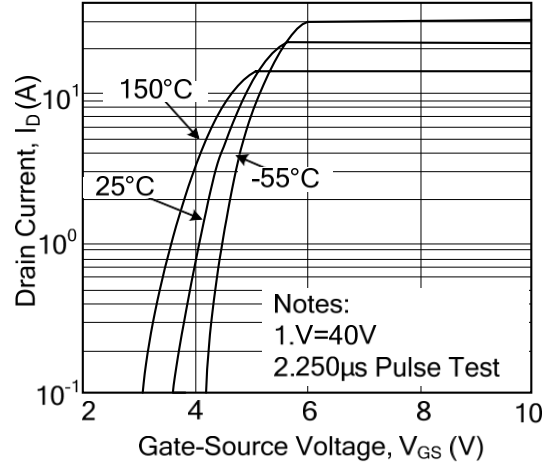

On-Resistance Variation vs. Drain Current and Gate Voltage

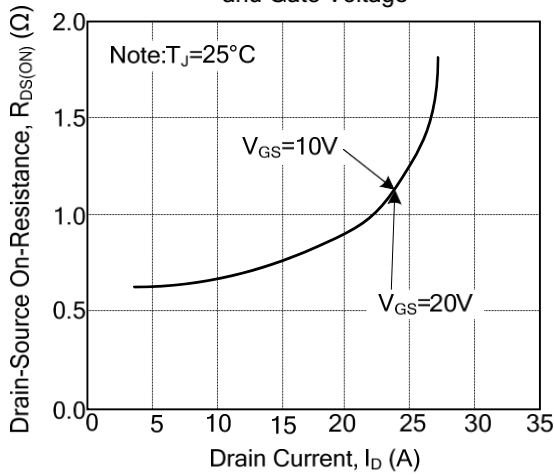

Body Diode Forward Voltage Variation with Source Current and Temperature

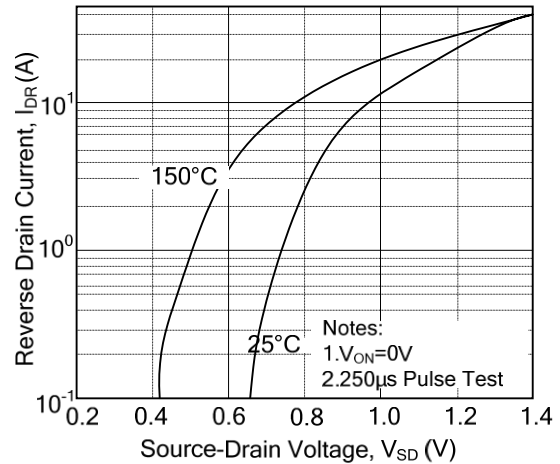

Capacitance Characteristics

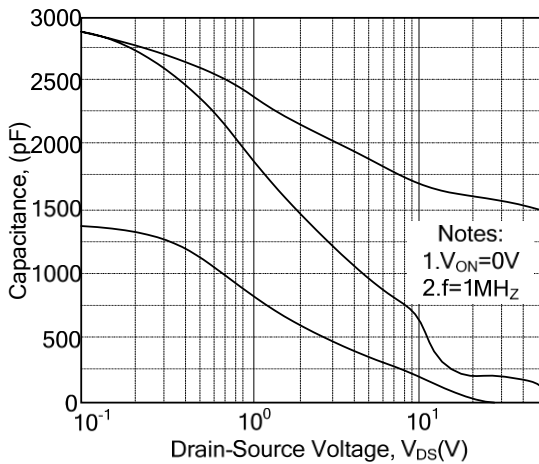

Gate Charge Characteristics

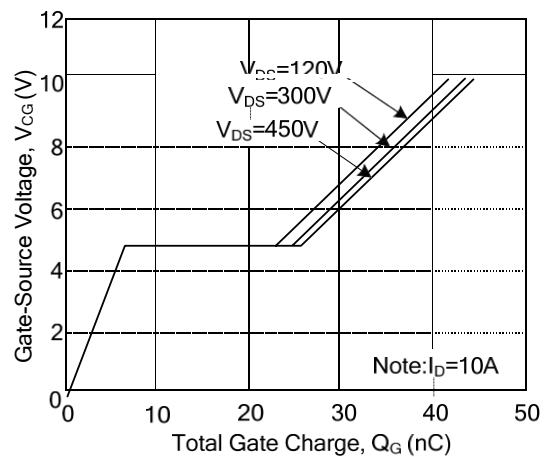

TYPICAL CHARACTERISTICS(Cont.)

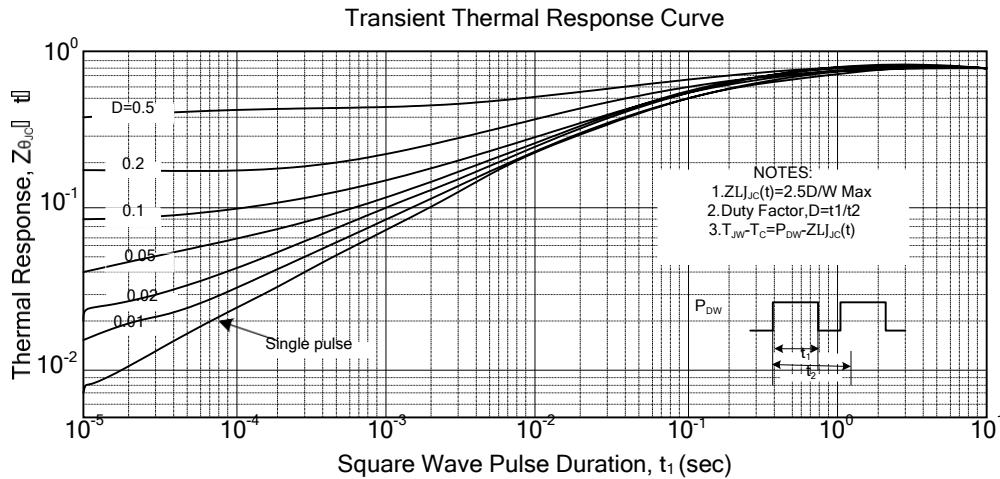
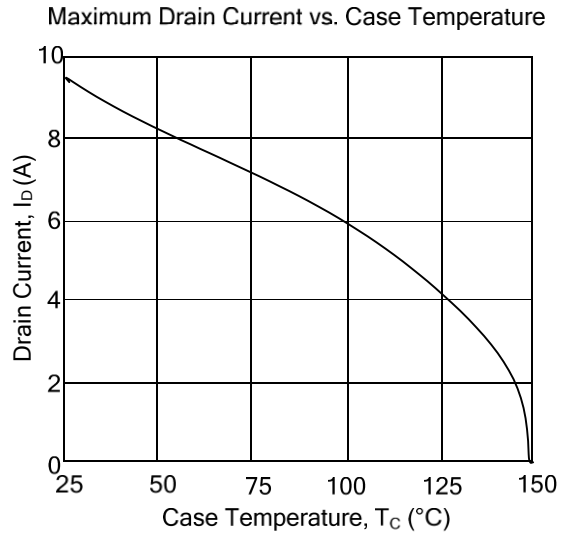
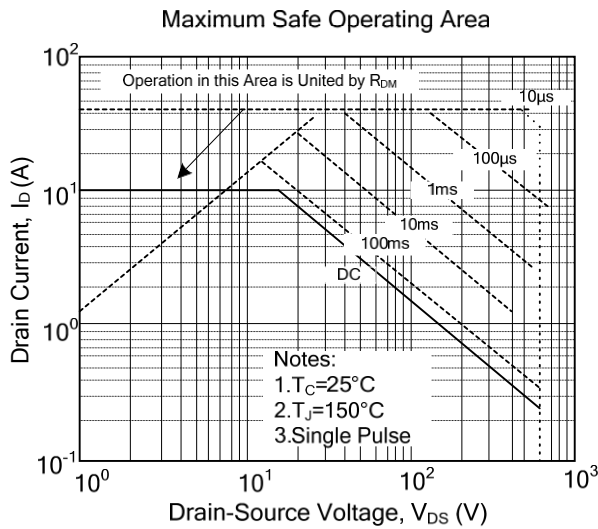
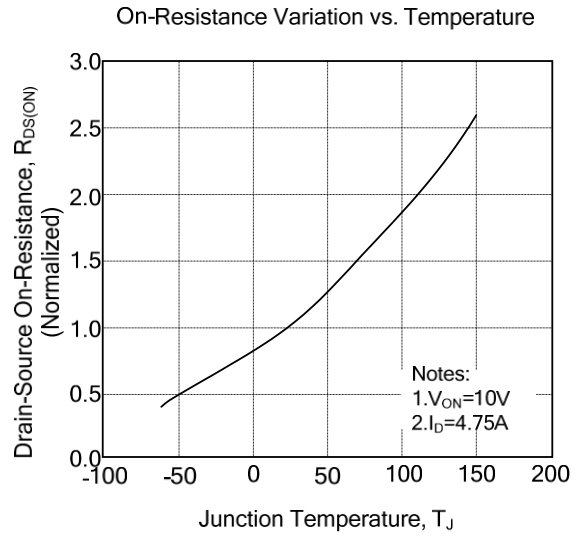
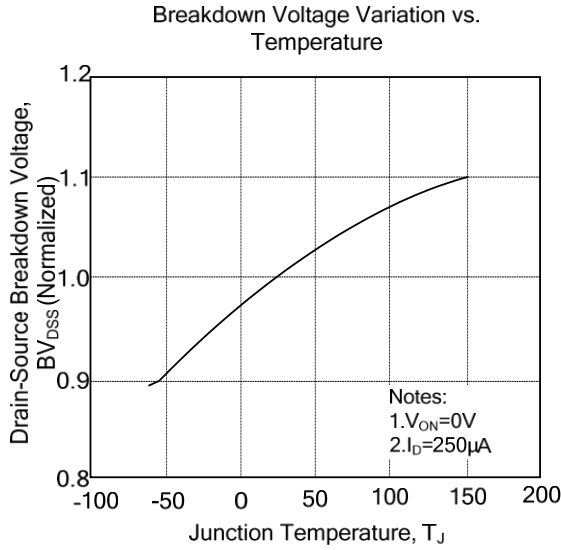

TO-220-3L Package Outline Dimensions

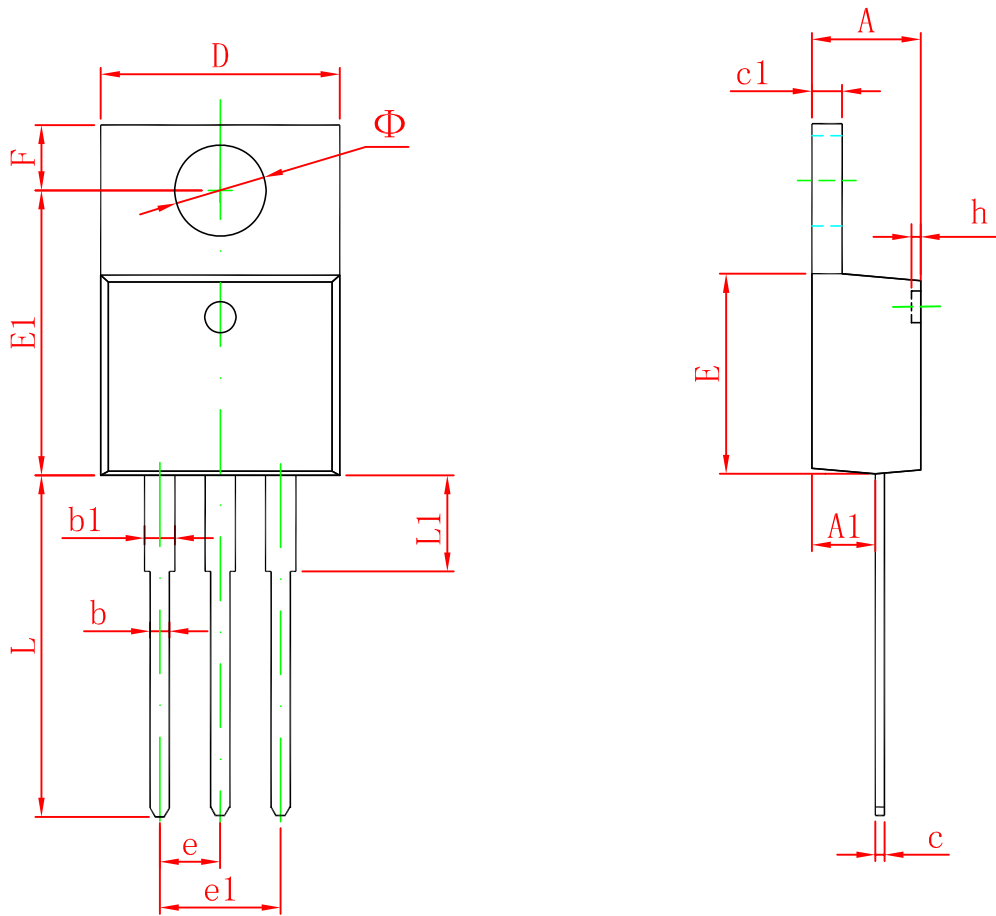

Symbol	Dimensions In Millimeters		Dimensions In Inches	
	Min	Max	Min	Max
A	4.470	4.670	0.176	0.184
A1	2.520	2.820	0.099	0.111
b	0.710	0.910	0.028	0.036
b1	1.170	1.370	0.046	0.054
c	0.310	0.530	0.012	0.021
c1	1.170	1.370	0.046	0.054
D	10.010	10.310	0.394	0.406
E	8.500	8.900	0.335	0.350
E1	12.060	12.460	0.475	0.491
e	2.540 TYP		0.100 TYP	
e1	4.980	5.180	0.196	0.204
F	2.590	2.890	0.102	0.114
h	0.000	0.300	0.000	0.012
L	13.400	13.800	0.528	0.543
L1	3.560	3.960	0.140	0.156
Φ	3.735	3.935	0.147	0.155

TO-220F Package Outline Dimensions

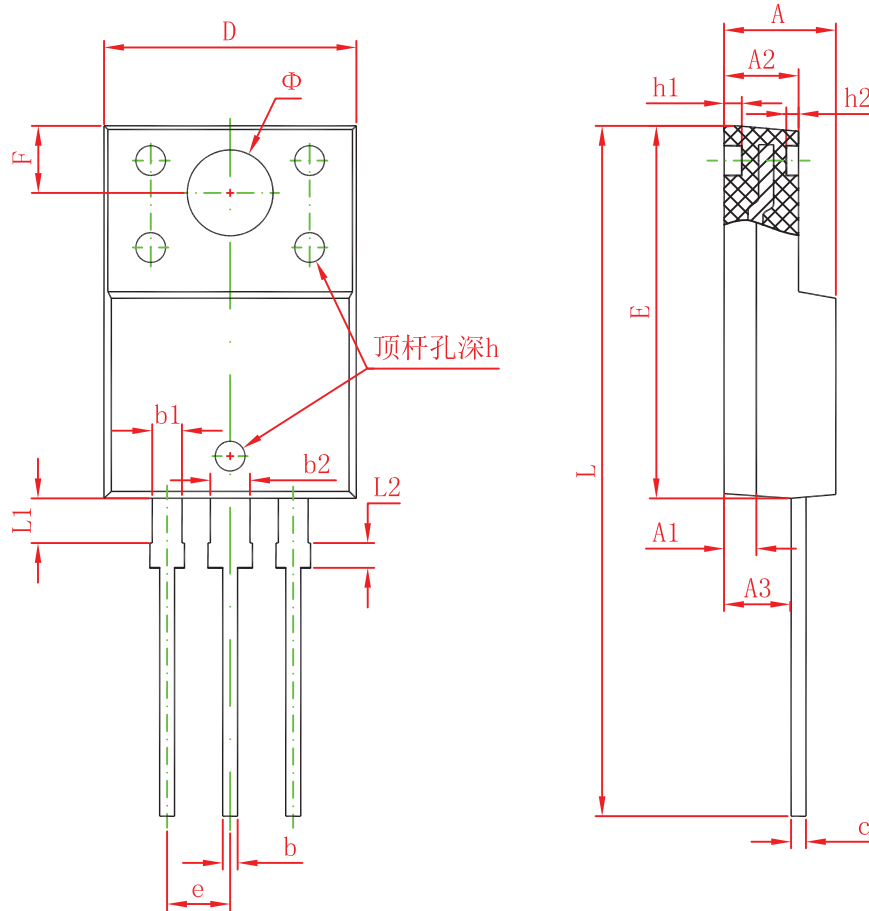

Symbol	Dimensions In Millimeters		Dimensions In Inches	
	Min.	Max.	Min.	Max.
A	4.300	4.700	0.169	0.185
A1	1.300 REF.		0.051 REF.	
A2	2.800	3.200	0.110	0.126
A3	2.500	2.900	0.098	0.114
b	0.500	0.750	0.020	0.030
b1	1.100	1.350	0.043	0.053
b2	1.500	1.750	0.059	0.069
c	0.500	0.750	0.020	0.030
D	9.960	10.360	0.392	0.408
E	14.800	15.200	0.583	0.598
e	2.540 TYP.		0.100 TYP.	
F	2.700 REF.		0.106 REF.	
Φ	3.500 REF.		0.138 REF.	
h	0.000	0.300	0.000	0.012
h1	0.800 REF.		0.031 REF.	
h2	0.500 REF.		0.020 REF.	
L	28.000	28.400	1.102	1.118
L1	1.700	1.900	0.067	0.075
L2	0.900	1.100	0.035	0.043

Packaging Specifications of Tube Pack for TO-220AB and ITO-220AB

TO-220AB&ITO-220AB Suggested Pad Layout

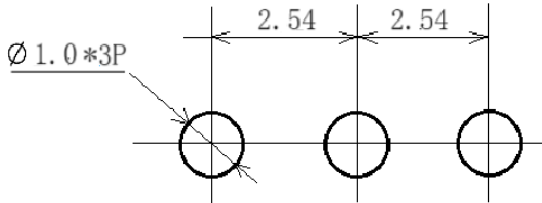

Note:

1. Controlling dimension: in millimeters.
2. General tolerance: $\pm 0.05\text{mm}$.
3. The pad layout is for reference purposes only.

1. The method of packaging and dimension are shown as below figure. (Dimension in mm)

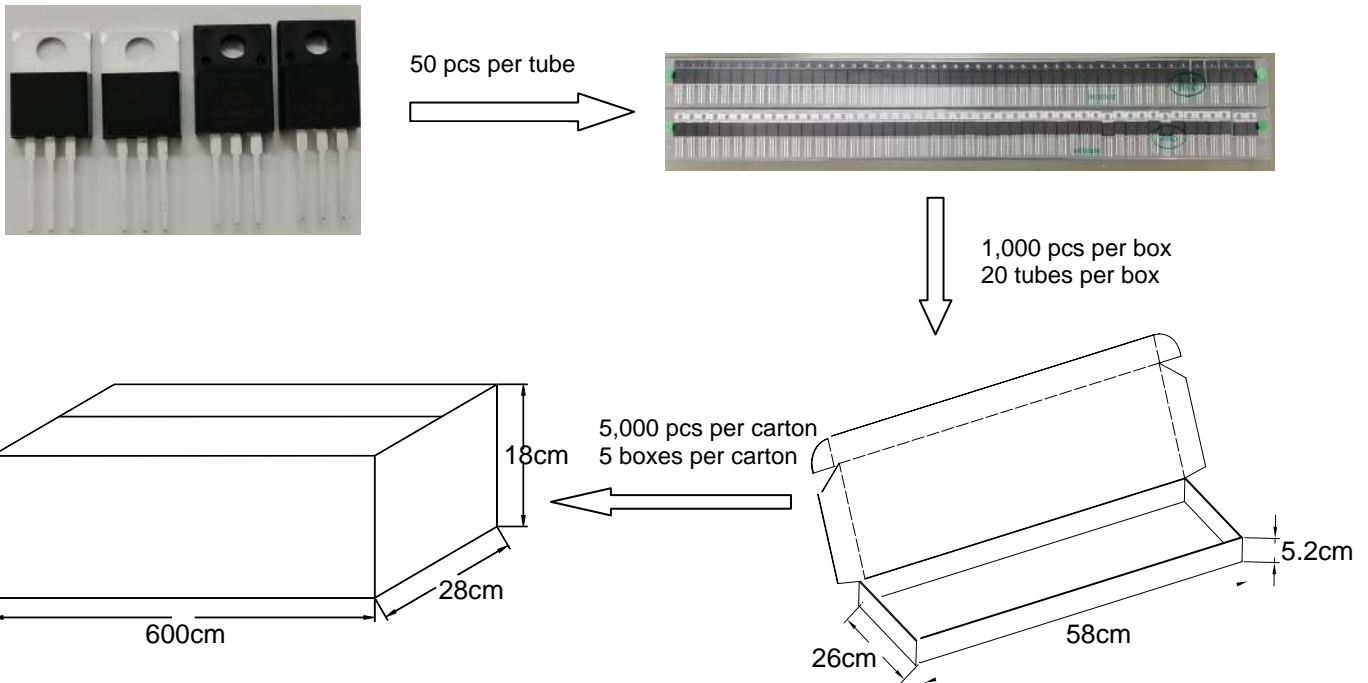

2. Tube data (Units: mm)

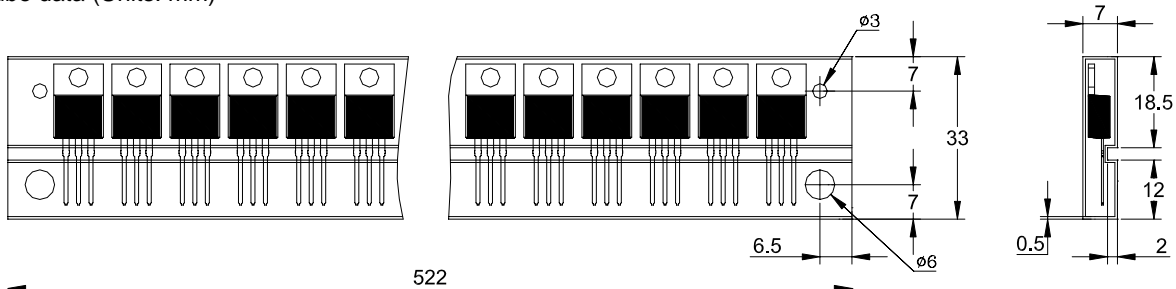

Storage

1. It is recommended to store the products in the following conditions:

Humidity: 75% R.H. Max.

Temperature : $0^{\circ}\text{C} \sim 35^{\circ}\text{C}$ ($32^{\circ}\text{F} \sim 95^{\circ}\text{F}$)

2. Shelf life : 12 month at $< 0^{\circ}\text{C} \sim 35^{\circ}\text{C}$ ($32^{\circ}\text{F} \sim 95^{\circ}\text{F}$) and $< 75\%$ R.H.