

4.0A 650V N-CHANNEL POWER MOSFET

Description:

The KW4N65 is a high voltage MOSFET and is designed to have better characteristics, such as fast switching time, low gate charge, low on-state resistance and have a high rugged avalanche characteristics. This power MOSFET is usually used at high speed switching applications in power supplies, PWM motor controls, high efficient DC to DC converters and bridge circuits.

Features:

- * $V_{DS} = 650V$
- * $I_D = 4.0A$
- * $R_{DS(ON)} = 2.5\Omega @ V_{GS} = 10V$.
- * Ultra Low gate charge (typical 15nC)
- * Low reverse transfer capacitance ($C_{RSS} =$ typical 8.0pF)
- * Fast switching capability
- * Avalanche energy specified
- * Improved dv/dt capability, high ruggedness

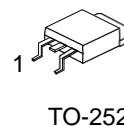
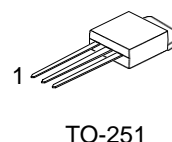
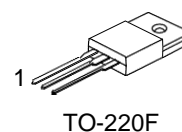
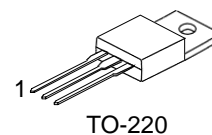

■ SYMBOL

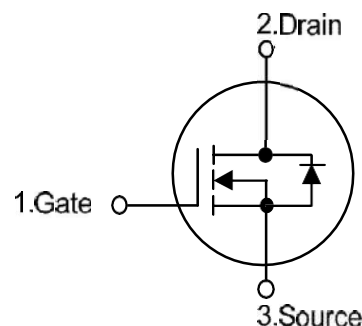

• ORDERING INFORMATION

Ordering Number	Package	Pin Assignment			Packing
		1	2	3	
KW4N65-LI	TO-220	G	D	S	Tape Box
KW4N65-BL	TO-220	G	D	S	Bulk
KW4N65F-LI	TO-220F	G	D	S	Tube
KW4N65A-LI	TO-251	G	D	S	Tube
KW4N65D-TR	TO-252	G	D	S	Tape Ree
KW4N65D-LI	TO-252	G	D	S	Tube

Note: Pin Assignment: G: Gate D: Drain S: Source

■ **ABSOLUTE MAXIMUM RATINGS** ($T_C = 25^\circ\text{C}$, unless otherwise specified)

PARAMETER	SYMBOL	RATINGS	UNIT	
Drain-Source Voltage	V_{DSS}	650	V	
Gate-Source Voltage	V_{GSS}	± 30	V	
Avalanche Current (Note2)	I_{AR}	4.4	A	
Drain Current	Continuous	I_D	4.0	A
	Pulsed (Note2)	I_{DM}	16	A
Avalanche Energy Single Pulsed (Note3)	KW4N65-E	E_{AS}	200	mJ
	Repetitive (Note2)	E_{AR}	10.6	mJ
Peak Diode Recovery dv/dt (Note4)	dv/dt	4.5	V/ns	
Power Dissipation	TO-220	P_D	106	W
	TO-220F		36	
	TO-251		50	
	TO-252		50	
Junction Temperature	T_J	+150	$^\circ\text{C}$	
Operating Temperature	T_{OPR}	-55 ~ +150	$^\circ\text{C}$	
Storage Temperature	T_{STG}	-55 ~ +150	$^\circ\text{C}$	

Note: 1. Absolute maximum ratings are those values beyond which the device could be permanently damaged.

Absolute maximum ratings are stress ratings only and functional device operation is not implied.

2. Repetitive Rating : Pulse width limited by maximum junction temperature

3. $L = 30\text{mH}$, $I_{AS} = 4\text{A}$, $V_{DD} = 50\text{V}$, $R_G = 25\ \Omega$, Starting $T_J = 25^\circ\text{C}$

4. $s_D \leq 4.4\text{A}$, $di/dt \leq 200\text{A}/\mu\text{s}$, $V_{DD} \leq BV_{DSS}$, Starting $T_J = 25^\circ\text{C}$

■ **THERMAL DATA**

PARAMETER	PACKAGE	SYMBOL	RATINGS	UNIT
Junction to Ambient	TO-220	θ_{JA}	62.5	$^\circ\text{C}/\text{W}$
	TO-220F			
	TO-251			
	TO-252			
Junction to Case	TO-220	θ_{JC}	1.18	$^\circ\text{C}/\text{W}$
	TO-220F		3.47	
	TO-251		2.5	
	TO-252		2.5	

■ **ELECTRICAL CHARACTERISTICS** ($T_C = 25^\circ\text{C}$, unless otherwise specified)

PARAMETER	SYMBOL	TEST CONDITIONS	MIN	TYP	MAX	UNIT	
OFF CHARACTERISTICS							
Drain-Source Breakdown Voltage	BV_{DSS}	$V_{GS} = 0\text{ V}, I_D = 250\mu\text{A}$	650			V	
Drain-Source Leakage Current	I_{DSS}	$V_{DS} = 650\text{ V}, V_{GS} = 0\text{ V}$			10	μA	
Gate-Source Leakage Current	Forward	$V_{GS} = 30\text{ V}, V_{DS} = 0\text{ V}$ $V_{GS} = -30\text{ V}, V_{DS} = 0\text{ V}$			100	nA	
	Reverse				-100	nA	
Breakdown Voltage Temperature Coefficient	$\Delta BV_{DSS}/\Delta T_J$	$I_D = 250\mu\text{A}$, Referenced to 25°C		0.6		$\text{V}/^\circ\text{C}$	
ON CHARACTERISTICS							
Gate Threshold Voltage	$V_{GS(TH)}$	$V_{DS} = V_{GS}, I_D = 250\mu\text{A}$	2.0			V	
Static Drain-Source On-State Resistance	KW4N65	$V_{GS} = 10\text{ V}, I_D = 2.2\text{A}$		2.4	2.5	Ω	
	KW4N65-E			2.4	2.5		
	KW4N65-N			2.9	3.1		
	KW4N65-Q			2.9	3.1		
DYNAMIC CHARACTERISTICS							
Input Capacitance	C_{ISS}	$V_{DS} = 25\text{ V}, V_{GS} = 0\text{V},$ $f = 1\text{MHz}$		520	670	pF	
Output Capacitance	C_{OSS}			70	90	pF	
Reverse Transfer Capacitance	C_{RSS}			8	11	pF	
SWITCHING CHARACTERISTICS							
Turn-On Delay Time	$t_{D(ON)}$	$V_{DS} = 325\text{V}, I_D = 4.0\text{A},$ $R_G = 25\Omega$ (Note 1, 2)		13	35	ns	
Turn-On Rise Time	KW4N65		t_R		70	100	ns
	KW4N65-E				60	100	
	KW4N65-N				70	100	
	KW4N65-Q				45	100	
Turn-Off Delay Time	$t_{D(OFF)}$			25	60	ns	
Turn-Off Fall Time	KW4N65		t_F		100	120	ns
	KW4N65-E				70	120	
	KW4N65-N				100	120	
	KW4N65-Q				35	120	
Total Gate Charge	Q_G	$V_{DS} = 520\text{V}, I_D = 4.0\text{A},$ $V_{GS} = 10\text{V}$ (Note 1, 2)		15	20	nC	
Gate-Source Charge	Q_{GS}			3.4		nC	
Gate-Drain Charge	Q_{GD}			7.1		nC	
SOURCE- DRAIN DIODE RATINGS AND CHARACTERISTICS							
Drain-Source Diode Forward Voltage	V_{SD}	$V_{GS} = 0\text{ V}, I_S = 4.4\text{A}$			1.4	V	
Maximum Continuous Drain-Source Diode Forward Current	I_S				4.4	A	
Maximum Pulsed Drain-Source Diode Forward Current	I_{SM}				17.6	A	
Reverse Recovery Time	t_{rr}	$V_{GS} = 0\text{V}, I_S = 4.4\text{A},$		250		ns	
Reverse Recovery Charge	Q_{RR}	$di_F/dt = 100\text{ A}/\mu\text{s}$ (Note 1)		1.5		μC	

Note: 1. Pulse Test: Pulse width $\leq 300\mu\text{s}$, Duty cycle $\leq 2\%$
 2. Essentially independent of operating temperature

TEST CIRCUITS AND WAVEFORMS

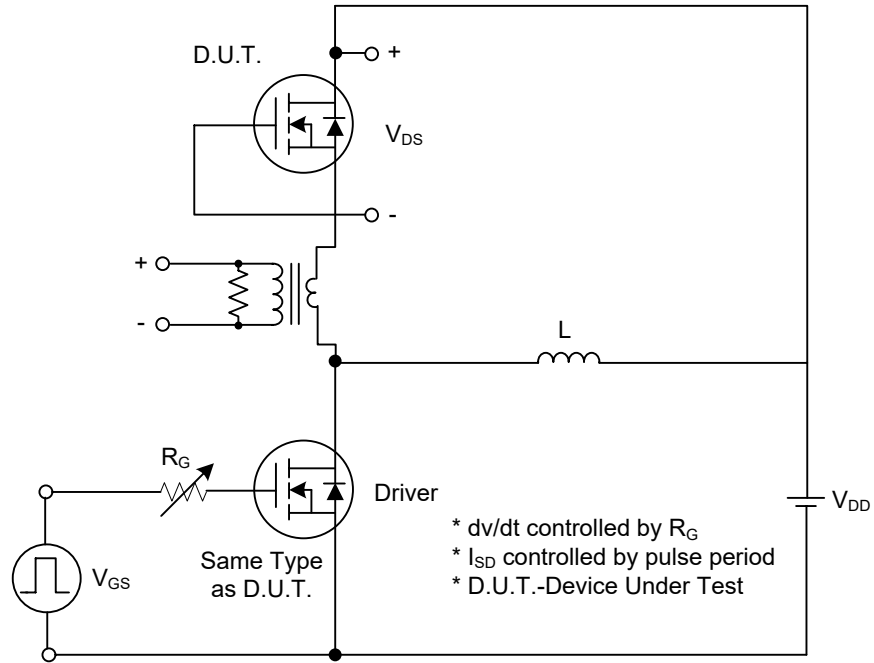

Peak Diode Recovery dv/dt Test Circuit

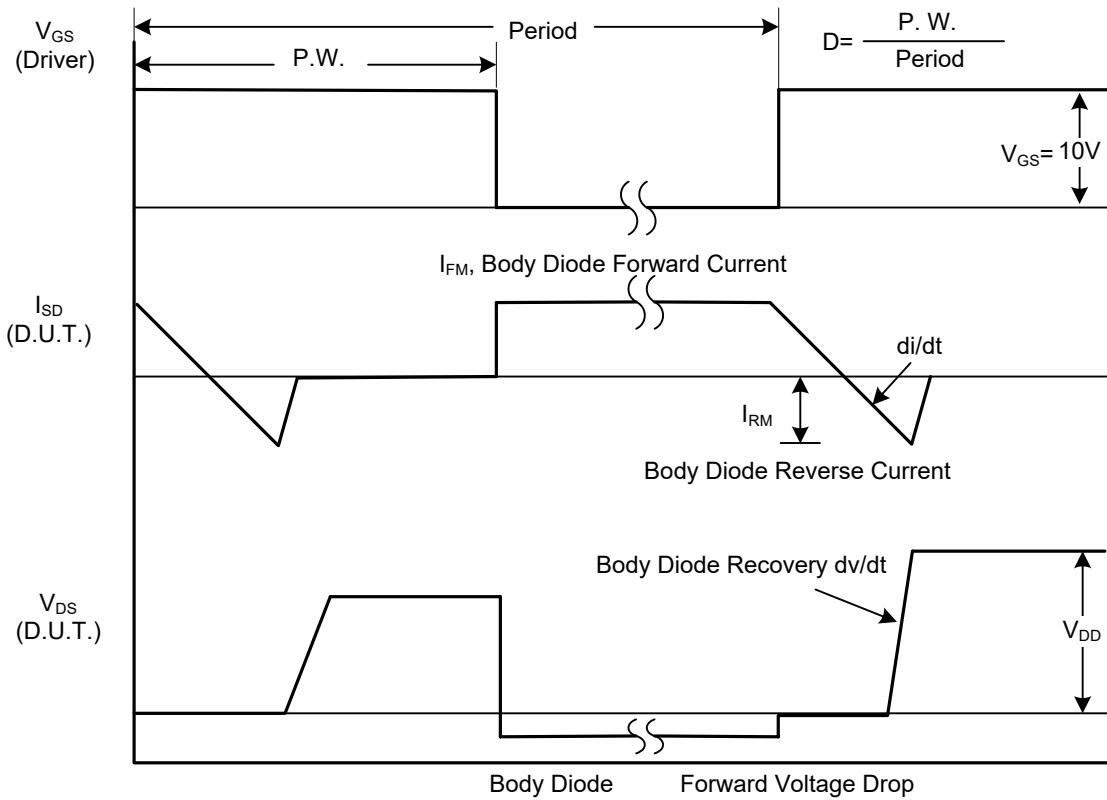

Peak Diode Recovery dv/dt Waveforms

TEST CIRCUITS AND WAVEFORMS(Cont.)

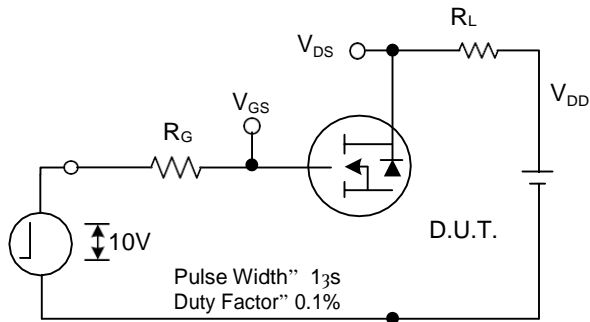

Switching Test Circuit

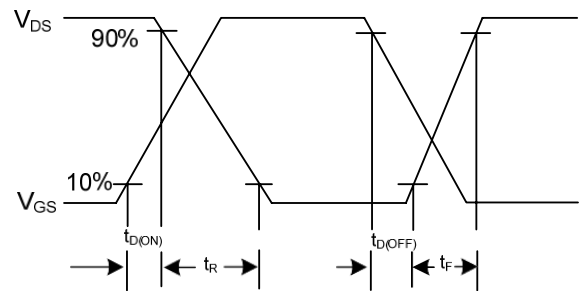

Switching Waveforms

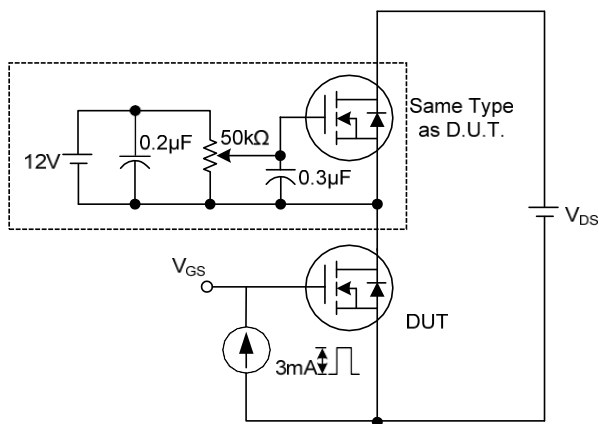

Gate Charge Test Circuit

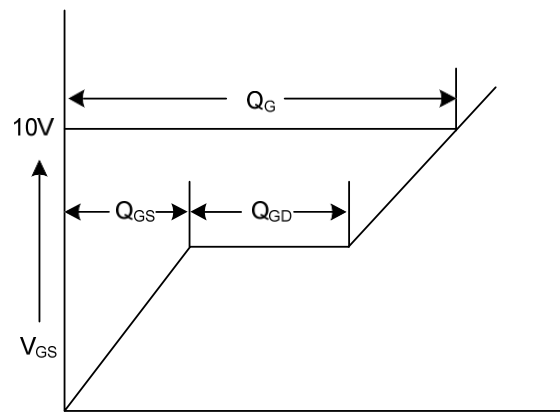

Gate Charge Waveform

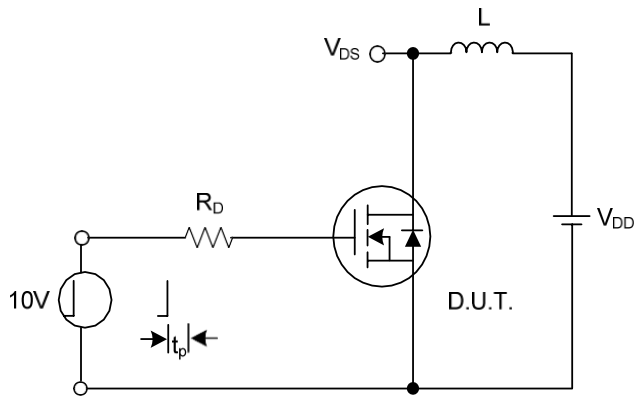

Unclamped Inductive Switching Test Circuit

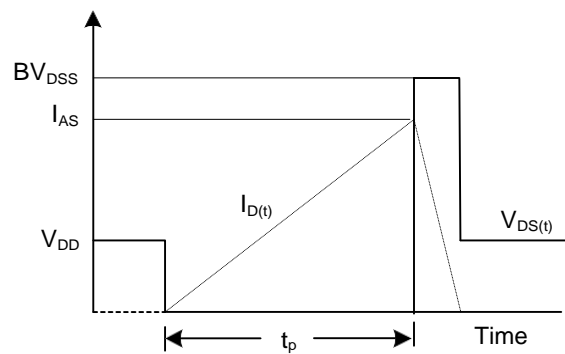

Unclamped Inductive Switching Waveforms

■ TYPICAL CHARACTERISTICS

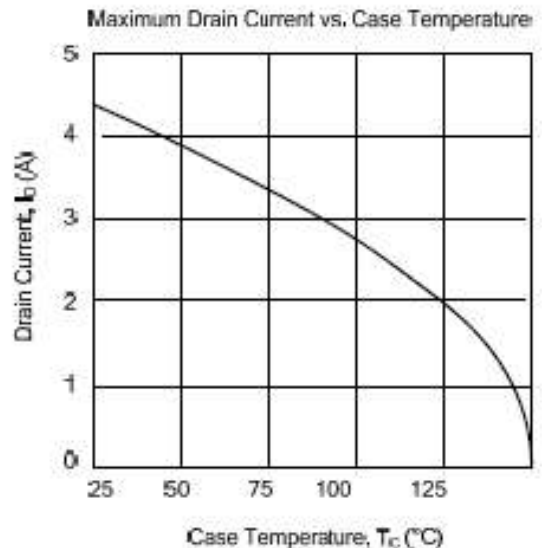
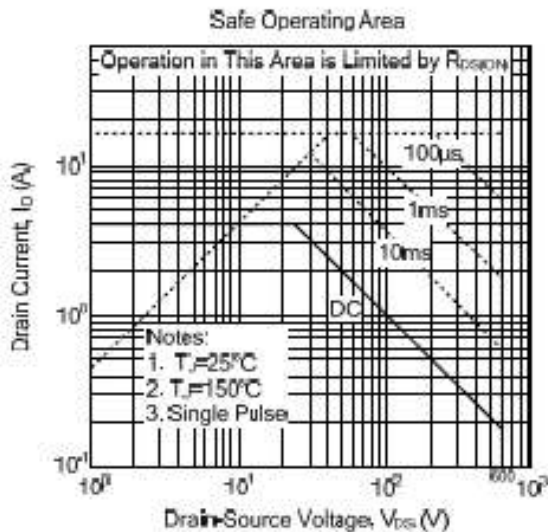
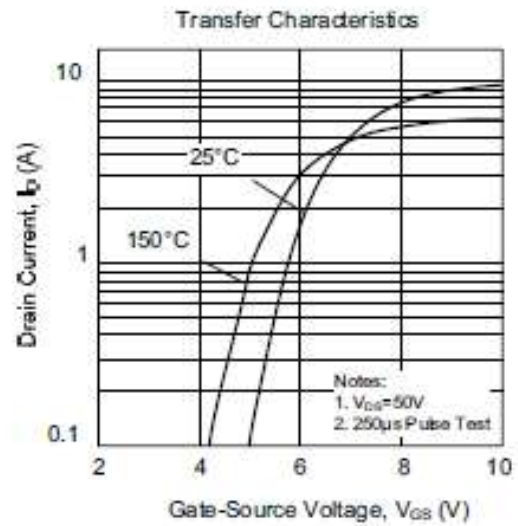
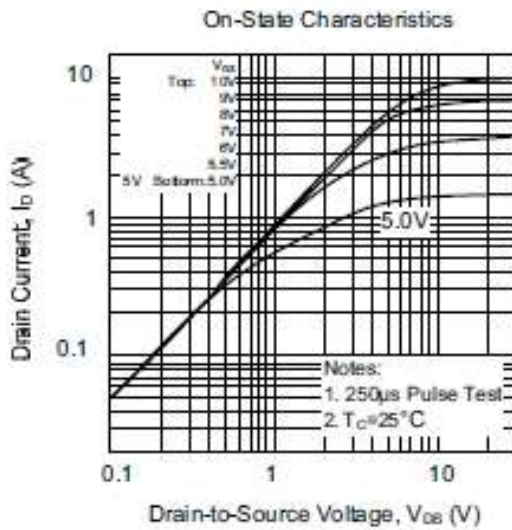
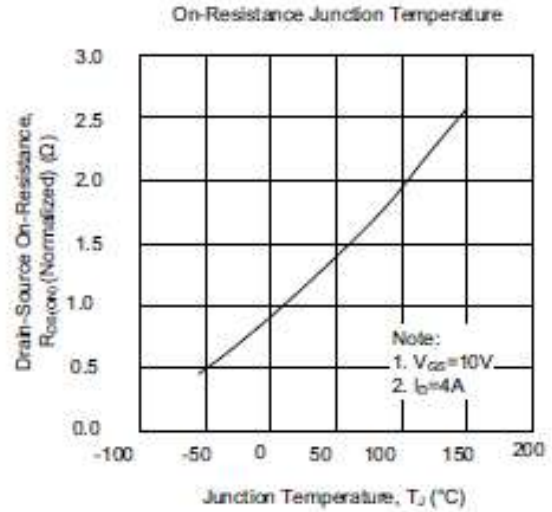
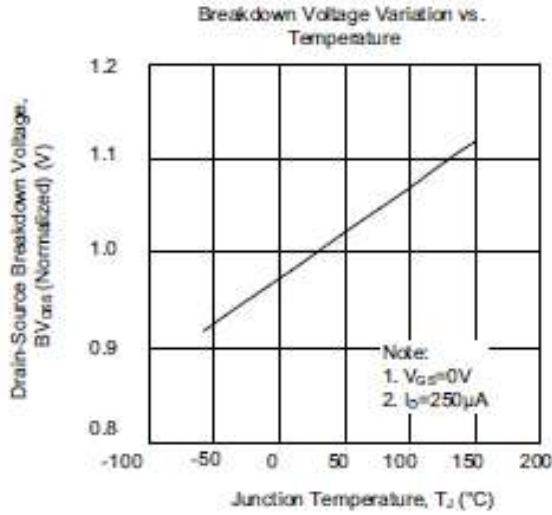

■ TYPICAL CHARACTERISTICS(Cont.)

