

MINI SURFACE MOUNT GLASS PASSIVATED BRIDGE RECTIFIERS

Features:

- * Ideal for printed circuit board
- * Reliable low cost construction utilizing molded plastic technique
- * High surge current capability
- * Polarity: marked on body
- * Mounting position: Any
- * Weight: 1.0 grams
- * Both normal and Pb free product are available:
- * Normal: 80~95%Sn, 5~20%Pb
- * Pb free: 99 Sn above can meet Rohs environment substance directive request

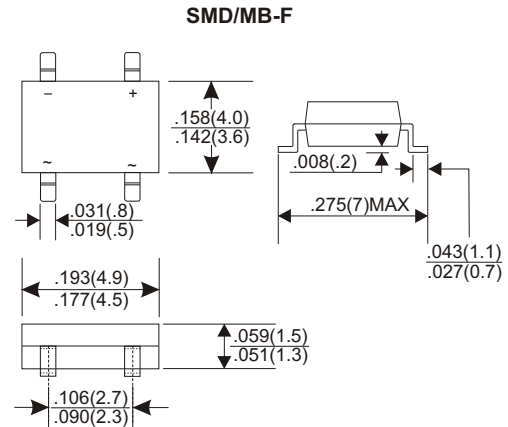

Dimensions in inches and (millimeters)

MAXIMUM RATINGS AND ELECTRICAL CHARACTERISTICS

Rating 25°C ambient temperature unless otherwise specified.
 Single phase half wave, 60Hz, resistive or inductive load.
 For capacitive load, derate current by 20%.

TYPE NUMBER	MB1F	MB2F	MB4F	MB6F	MB8F	MB10F	UNITS
Maximum Recurrent Peak Reverse Voltage	100	200	400	600	800	1000	V
Maximum RMS Voltage	700	140	280	420	560	700	V
Maximum DC Blocking Voltage	100	200	400	600	800	1000	V
Maximum Average Forward Rectified Current .375" (9.5mm) Lead Length at Ta=40°C	1.0						A
Peak Forward Surge Current, 8.3 ms single half sine-wave superimposed on rated load (JEDEC method)	30						A
Maximum Forward Voltage Drop per Bridge Element at 1.0A D.C.	1.0						V
Maximum DC Reverse Current Ta=25°C	5						uA
at Rated DC Blocking Voltage Ta=125°C	500						uA
Operating Temperature Range, Tj	-65 — +150						°C
Storage Temperature Range, TSTG	-65 — +150						°C

RATING AND CHARACTERISTIC CURVES (MB1F THRU MB10F)

FIG.1-TYPICAL FORWARD CURRENT DERATING CURVE

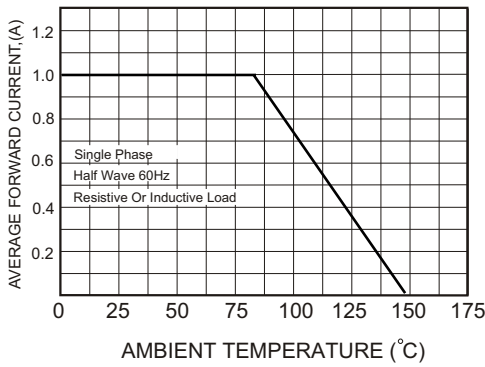

FIG.2-MAXIMUM NON-REPETITIVE FORWARD SURGE CURRENT

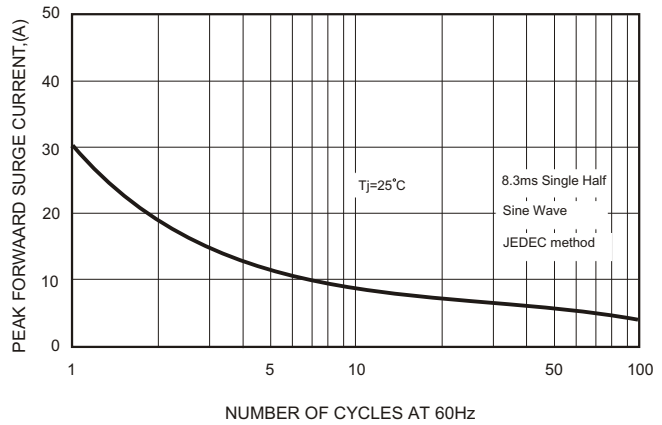

FIG.3-TYPICAL FORWARD CHARACTERISTICS

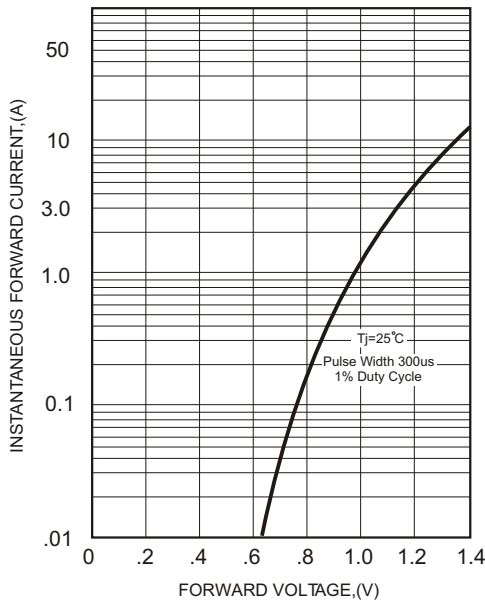

FIG.4-TYPICAL REVERSE CHARACTERISTICS

