

## TO-92 Plastic-Encapsulate Transistors

TRANSISTOR (NPN)

### Features:

- General Purpose Amplifier

### MARKING

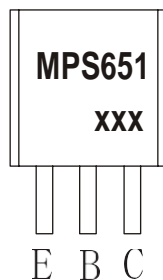

MPS651=Device code  
 XXX=Code

TO - 92

1.EMITTER

2.BASE

3.COLLECTOR

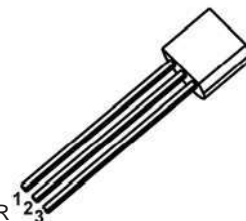

### Equivalent Circuit

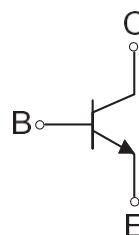

### ORDERING INFORMATION

Part Number	Package	Packing Method	Pack Quantity
MPS651	TO-92	Bulk	1000pcs/Bag
MPS651-TA	TO-92	Tape	2000pcs/Box

### MAXIMUM RATINGS (T<sub>a</sub>=25°C unless otherwise noted)

Symbol	Parameter	Value	Unit
V <sub>CB0</sub>	Collector-Base Voltage	80	V
V <sub>CEO</sub>	Collector-Emitter Voltage	60	V
V <sub>EBO</sub>	Emitter-Base Voltage	5	V
I <sub>C</sub>	Collector Current -Continuous	4	A
P <sub>D</sub>	Collector Power Dissipation	750	mW
R <sub>θJA</sub>	Thermal Resistance rom Junction to Ambient	210	°C /W
T <sub>J</sub> ,T <sub>stg</sub>	Operation Junction and Storage Temperature Range	-55~+150	°C

## ELECTRICAL CHARACTERISTICS

T =25 °C unless otherwise specified

Parameter	Symbol	Test conditions	Min	Typ	Max	Unit
Collector-base breakdown voltage	$V_{(BR)CBO}$	$I_C=0.1mA, I_E=0$	80			V
Collector-emitter breakdown	$V_{(BR)CEO}^*$	$I_C=10mA, I_B=0$	60			V
Emitter-base breakdown voltage	$V_{(BR)EBO}$	$I_E=0.01mA, I_C=0$	5			V
Collector cut-off current	$I_{CBO}$	$V_{CB}=80V, I_E=0$			0.1	$\mu A$
Emitter cut-off current	$I_{EBO}$	$V_{EB}=4V, I_C=0$			0.1	$\mu A$
DC current gain	$h_{FE(1)}^*$	$V_{CE}=2V, I_C=50mA$	75			
	$h_{FE(2)}^*$	$V_{CE}=2V, I_C=500mA$	75			
	$h_{FE(3)}^*$	$V_{CE}=2V, I_C=1A$	75			
	$h_{FE(4)}^*$	$V_{CE}=2V, I_C=2A$	40			
Collector-emitter saturation voltage	$V_{CE(sat)(1)}^*$	$I_C=2A, I_B=200mA$			0.5	V
	$V_{CE(sat)(2)}^*$	$I_C=1A, I_B=100mA$			0.3	V
Base-emitter saturation voltage	$V_{BE(sat)}^*$	$I_C=1A, I_B=100mA$			1.2	V
Base-emitter voltage	$V_{BE}$	$I_C=1A, V_{CE}=2V$			1	V
Transition frequency	$f_T$	$V_{CE}=5V, I_C=50mA, f=100MHz$	75			MHz

\*Pulse test: pulse width  $\leq 300\mu s$ , duty cycles  $\leq 2.0\%$ .

**Typical Characteristics**

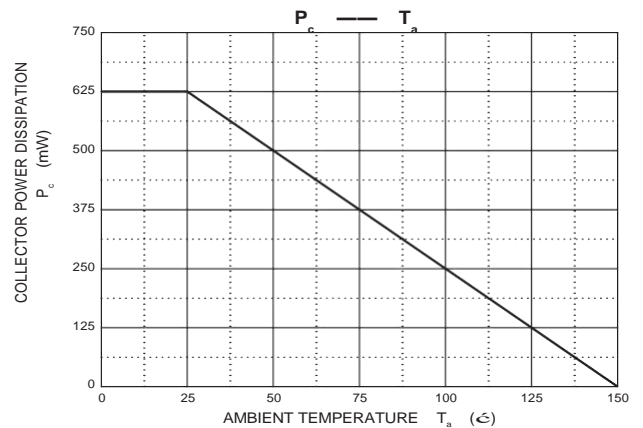
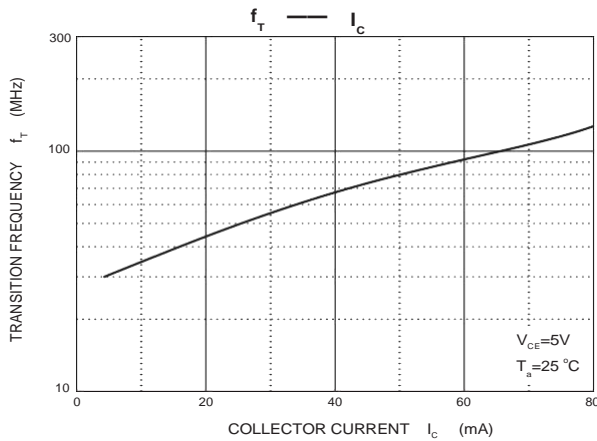
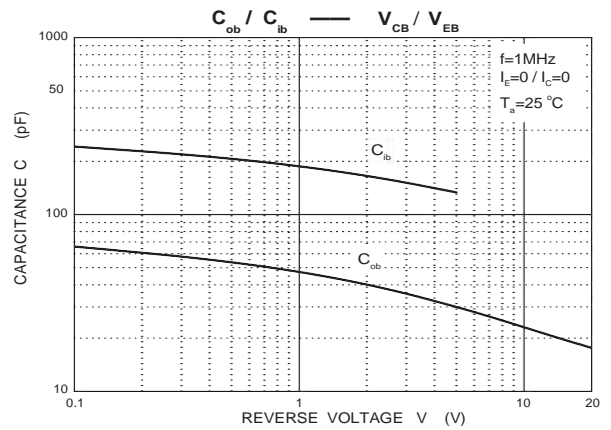
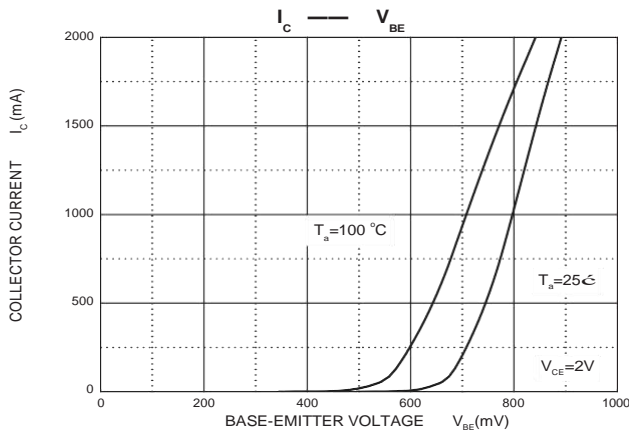
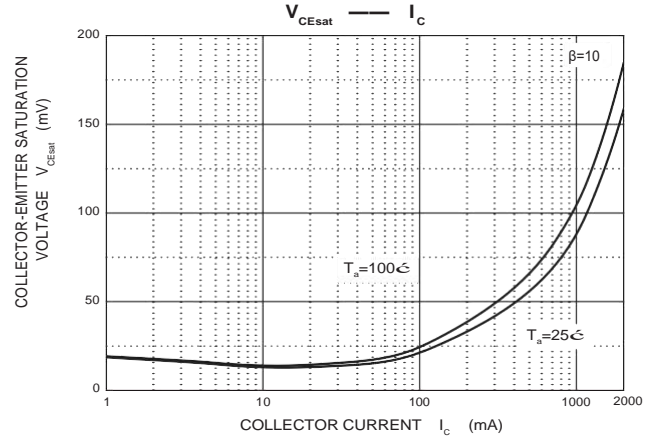
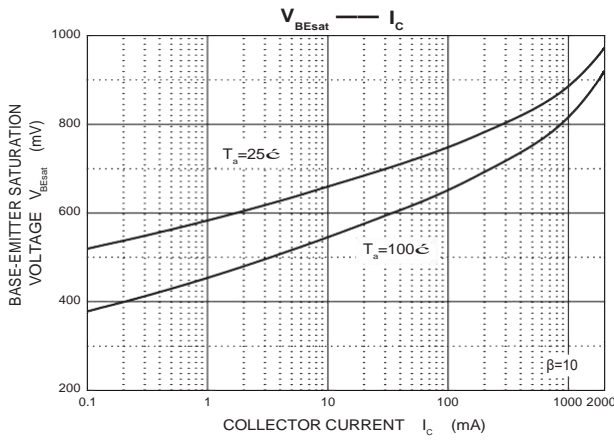
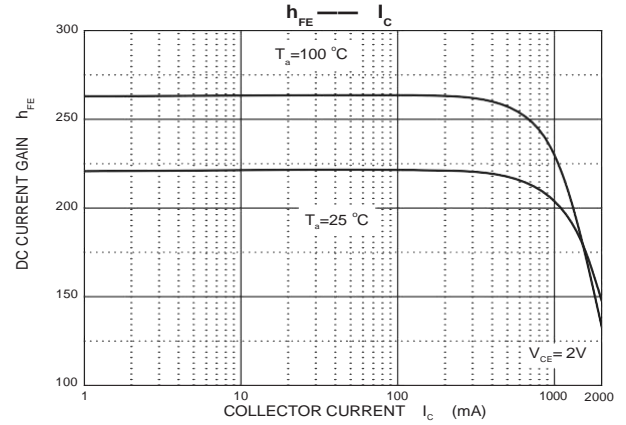
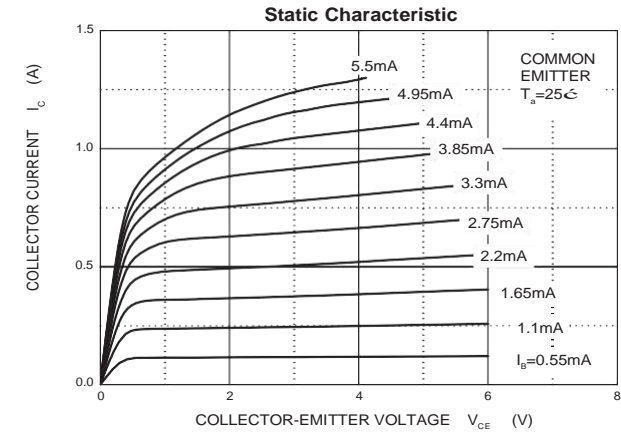

**TO-92 Package Outline Dimensions**

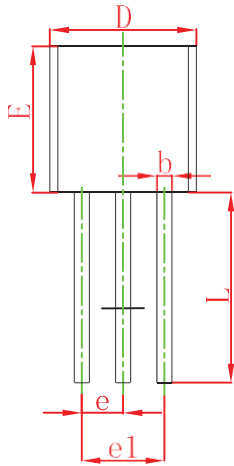
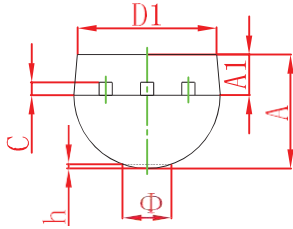

Symbol	Dimensions In Millimeters		Dimensions In Inches	
	Min	Max	Min	Max
A	3.300	3.700	0.130	0.146
A1	1.100	1.400	0.043	0.055
b	0.380	0.550	0.015	0.022
c	0.360	0.510	0.014	0.020
D	4.300	4.700	0.169	0.185
D1	3.430		0.135	
E	4.300	4.700	0.169	0.185
e	1.270 TYP		0.050 TYP	
e1	2.440	2.640	0.096	0.104
L	14.100	14.500	0.555	0.571
Φ		1.600		0.063
h	0.000	0.380	0.000	0.015

**TO-92 Suggested Pad Layout**

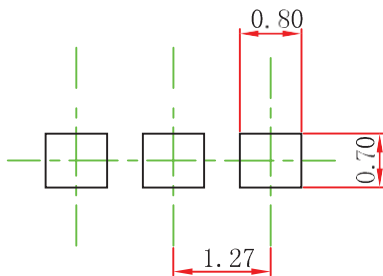

- Note:
1. Controlling dimension: in millimeters.
  2. General tolerance: ± 0.05mm.
  3. The pad layout is for reference purposes only.

**TO-92 Tape and Reel**

**TO-92 PACKAGE TAPEING DIMENSION**

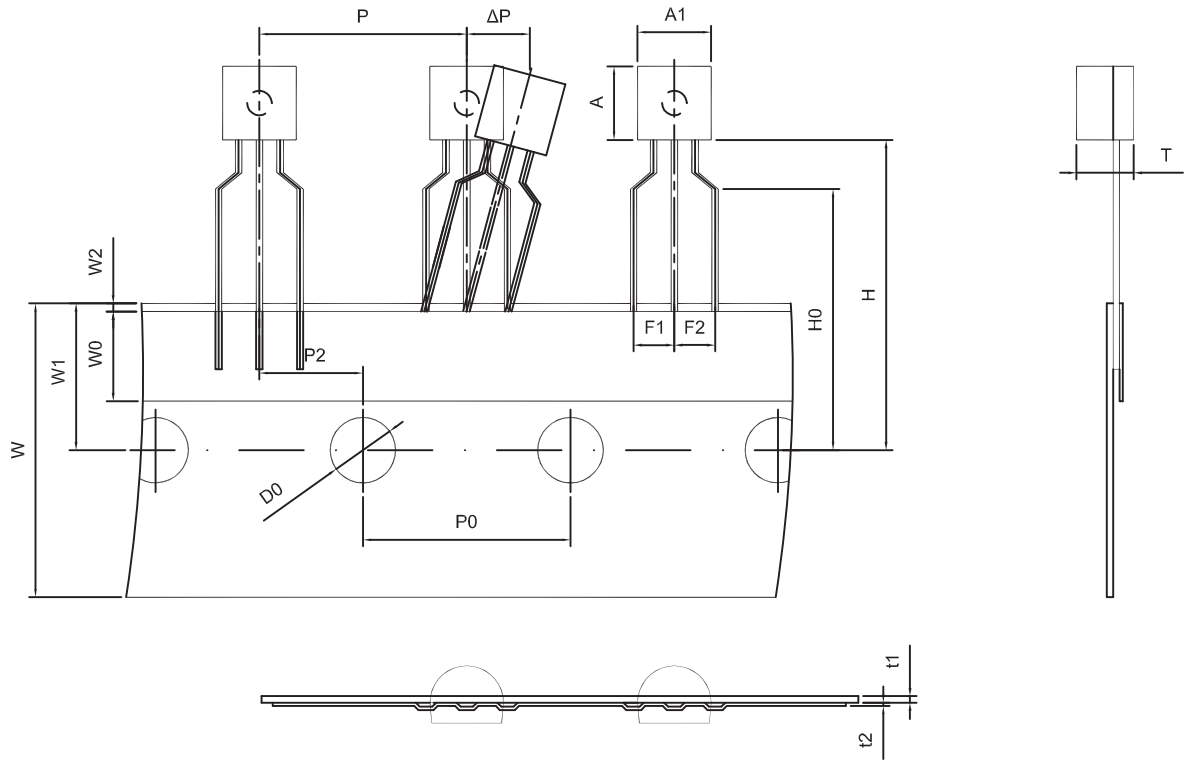

**Dimensions are in millimeter**

A1	A	T	P	P0	P2	F1	F2	W
4.5	4.5	3.5	12.7	12.7	6.35	2.5	2.5	18.0
W0	W1	W2	H	H0	D0	t1	t2	ΔP
6.0	9.0	1.0 MAX.	19.0	16.0	4.0	0.4	0.2	0

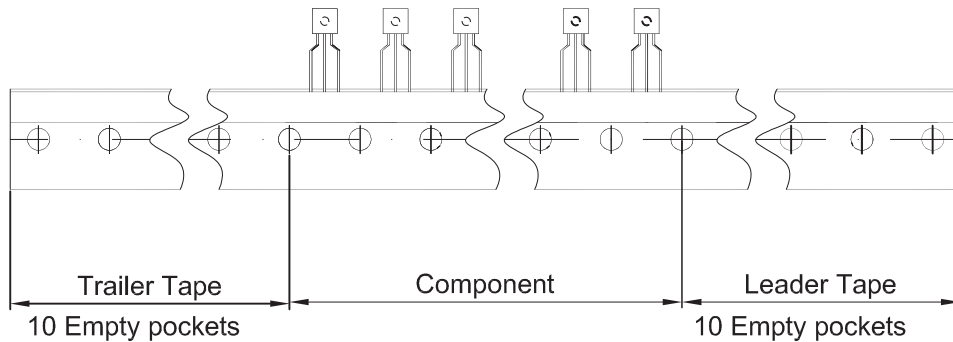

Package	Box	Box Size(mm)	Carton	Carton Size(mm)
TO-92	2000 pcs	333×162×43	20,000 pcs	350×340×250