

TO-92 Plastic-Encapsulate Transistors

TRANSISTOR (PNP)

Features:

- PNP silicon epitaxial planar transistor for switching and Amplifier applications
- As complementary type, the NPN transistor 2N3904 is Recommended
- This transistor is also available in the SOT-23 case with the type designation MMBT3906

MARKING

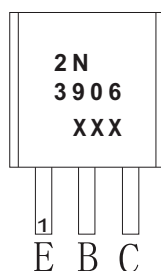

2N3906=Device code
 XXX=Code

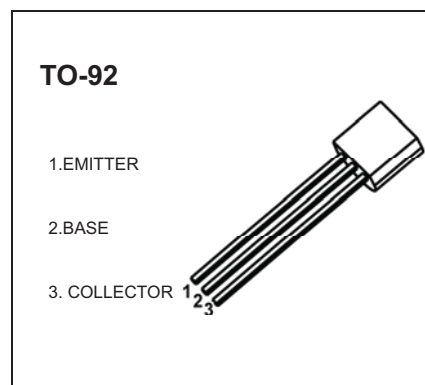

Equivalent Circuit

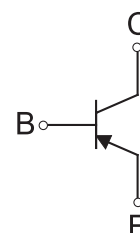

ORDERING INFORMATION

Part Number	Package	Packing Method	Pack Quantity
2N3906	TO-92	Bulk	1000pcs/Bag
2N3906-TA	TO-92	Tape	2000pcs/Box

MAXIMUM RATINGS($T_a=25^{\circ}\text{C}$ unless otherwise noted)

Symbol	Parameter	Value	Unit
V_{CBO}	Collector-Base Voltage	-40	V
V_{CEO}	Collector-Emitter Voltage	-40	V
V_{EBO}	Emitter-Base Voltage	-5	V
I_C	Collector Current-Continuous	-0.2	A
P_C	Collector Power Dissipation	0.625	W
T_J, T_{stg}	Operation Junction and Storage Temperature Range	-55~150	$^{\circ}\text{C}$

ELECTRICAL CHARACTERISTICS

$T_a=25\text{ }^\circ\text{C}$ unless otherwise specified

Parameter	Symbol	Test conditions	Min	Typ	Max	Unit
Collector-base breakdown voltage	$V_{(BR)CBO}$	$I_C = -10\mu\text{A}, I_E=0$	-40			V
Collector-emitter breakdown voltage	$V_{(BR)CEO}$	$I_C = -1\text{mA}, I_B=0$	-40			V
Emitter-base breakdown voltage	$V_{(BR)EBO}$	$I_E = -10\mu\text{A}, I_C=0$	-5			V
Collector cut-off current	I_{CBO}	$V_{CB} = -40\text{ V}, I_E=0$			-0.1	μA
Collector cut-off current	I_{CEX}	$V_{CE} = -30\text{ V}, V_{EB(off)} = -3\text{V}$			-50	nA
Emitter cut-off current	I_{EBO}	$V_{EB} = -5\text{ V}, I_C=0$			-0.1	μA
DC current gain	h_{FE1}	$V_{CE} = -1\text{ V}, I_C = -10\text{mA}$	100		400	
	h_{FE2}	$V_{CE} = -1\text{ V}, I_C = -50\text{mA}$	60			
	h_{FE3}	$V_{CE} = -2\text{ V}, I_C = -100\text{mA}$	30			
Collector-emitter saturation voltage	$V_{CE(sat)}$	$I_C = -50\text{mA}, I_B = -5\text{mA}$			-0.4	V
Base-emitter saturation voltage	$V_{BE(sat)}$	$I_C = -50\text{mA}, I_B = -5\text{mA}$			-0.95	V
Transition frequency	f_T	$V_{CE} = -20\text{V}, I_C = -10\text{mA}$ $f = 100\text{MHz}$	250			MHz
Delay Time	t_d	$V_{CC} = -3\text{V}, V_{BE} = -0.5\text{V},$			35	ns
Rise Time	t_r	$I_C = -10\text{mA}, I_{B1} = -1\text{mA}$			35	ns
Storage Time	t_s	$V_{CC} = -3\text{V}, I_C = -10\text{mA}$			225	ns
Fall Time	t_f	$I_{B1} = I_{B2} = -1\text{mA}$			75	ns

CLASSIFICATION OF h_{FE1}

Rank	O	Y	G
Range	100-200	200-300	300-400

Typical Characteristics

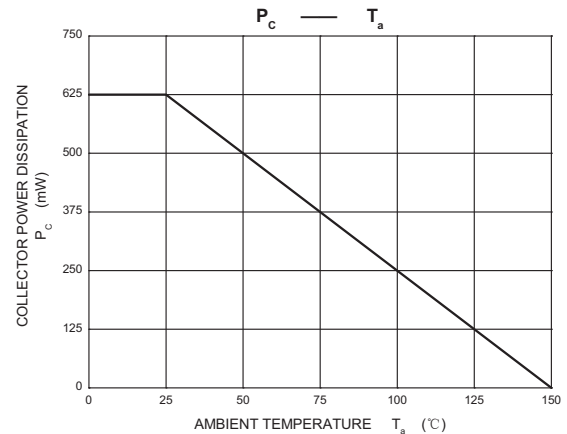
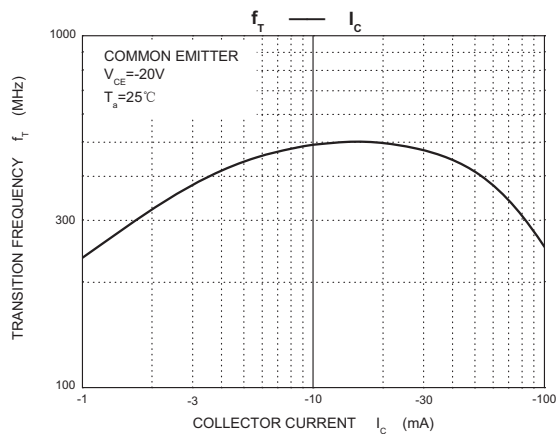
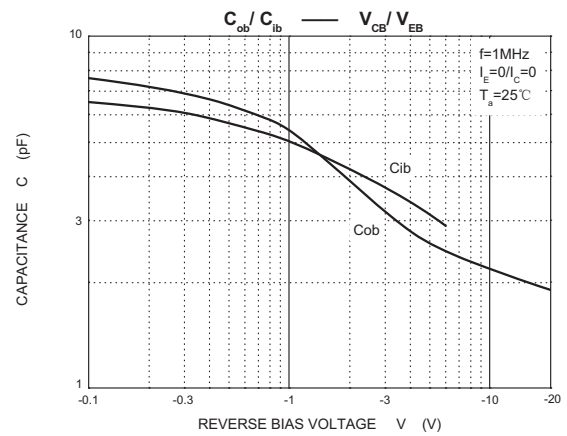
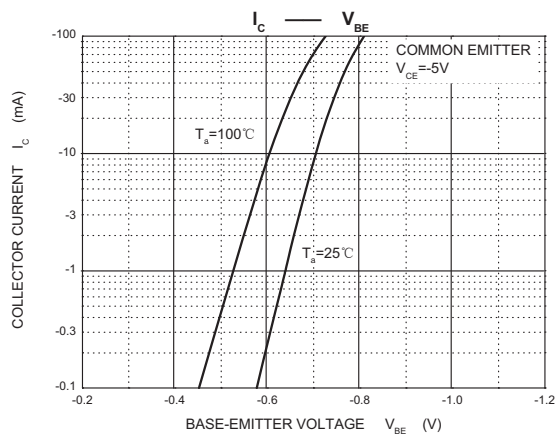
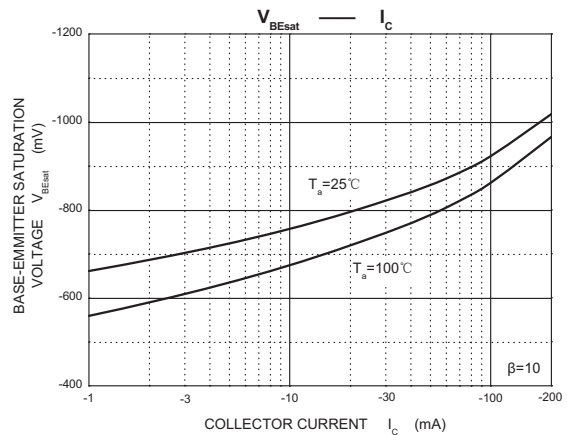
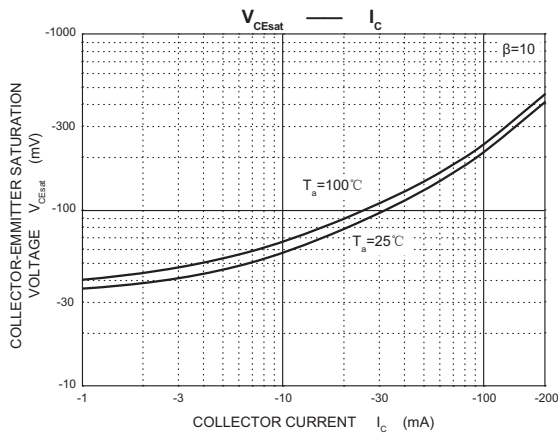
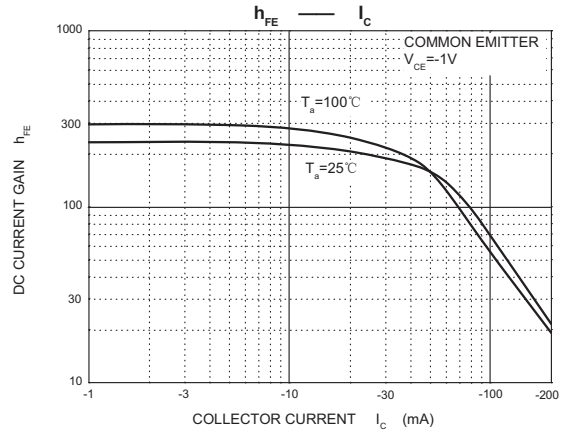
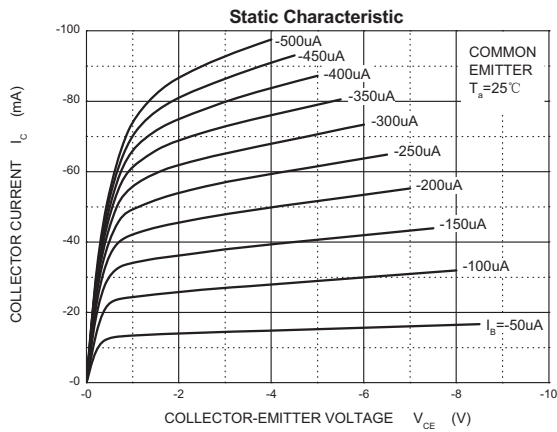

TO-92 Package Outline Dimensions

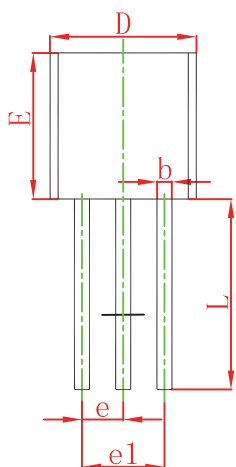
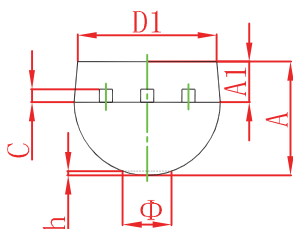

Symbol	Dimensions In Millimeters		Dimensions In Inches	
	Min	Max	Min	Max
A	3.300	3.700	0.130	0.146
A1	1.100	1.400	0.043	0.055
b	0.380	0.550	0.015	0.022
c	0.360	0.510	0.014	0.020
D	4.300	4.700	0.169	0.185
D1	3.430		0.135	
E	4.300	4.700	0.169	0.185
e	1.270 TYP		0.050 TYP	
e1	2.440	2.640	0.096	0.104
L	14.100	14.500	0.555	0.571
Φ		1.600		0.063
h	0.000	0.380	0.000	0.015

TO-92 Suggested Pad Layout

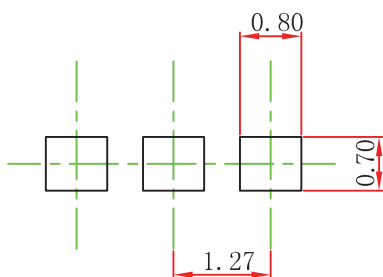

Note:

1. Controlling dimension: in millimeters.
2. General tolerance: $\pm 0.05\text{mm}$.
3. The pad layout is for reference purposes only.

TO-92 Tape

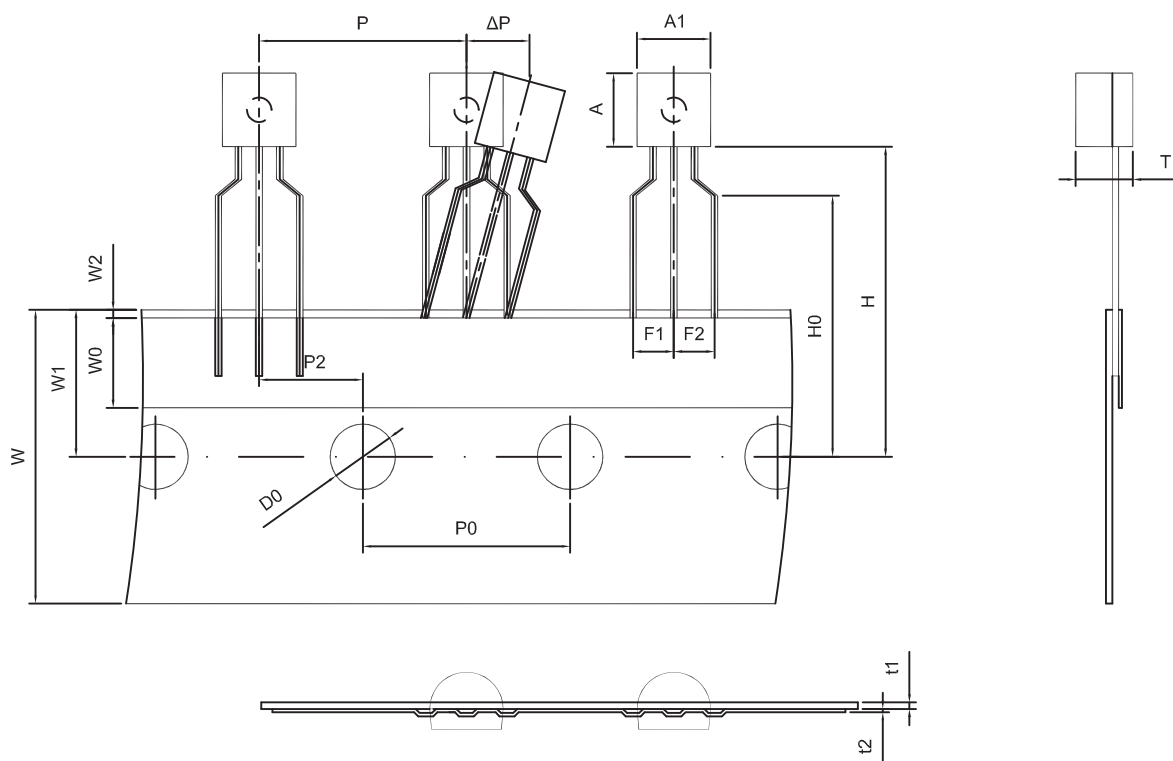

Dimiensions are in millimeter

A1	A	T	P	P0	P2	F1	F2	W
4.5	4.5	3.5	12.7	12.7	6.35	2.5	2.5	18.0
W0	W1	W2	H	H0	D0	t1	t2	ΔP
6.0	9.0	1.0 MAX.	19.0	16.0	4.0	0.4	0.2	0

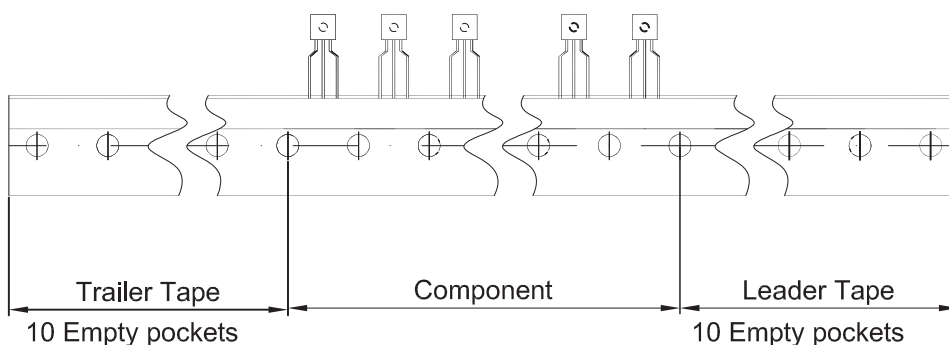

Package	Box	Box Size(mm)	Carton	Carton Size(mm)
TO-92	2000 pcs	333×162×43	20,000 pcs	350×340×250