

N-Channel Enhancement Mode Power MOSFET

Features:

- Low On Resistance
- Low Gate Charge
- Fast Switching Characteristic

TO-252

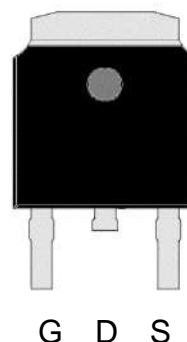

BV_{DSS}	200V
$I_D @ V_{GS}=10V, T_C=25^\circ C$	7.5A
$I_D @ V_{GS}=10V, T_A=25^\circ C$	2A
$R_{DS(ON)}$ typ. @ $V_{GS}=10V, I_D=2A$	302m Ω
$R_{DS(ON)}$ typ. @ $V_{GS}=4.5V, I_D=2A$	303m Ω

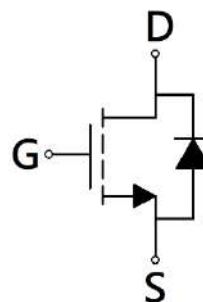

G : Gate S : Source D : Drain

Ordering Information

Device	Package	Shipping
KJD300N20	TO-252 (Pb-free lead plating and RoHS compliant package)	2500 pcs / Tape & Reel

Absolute Maximum Ratings (T_A=25°C)

Parameter	Symbol	Limits	Unit	
Drain-Source Voltage	V _{DS}	200	V	
Gate-Source Voltage	V _{GS}	±20		
Continuous Drain Current @ V _{GS} =10V, T _C =25°C	I _D	7.5	A	
Continuous Drain Current @ V _{GS} =10V, T _C =100°C		4.7		
Continuous Drain Current @ V _{GS} =10V, T _A =25°C		2		
Continuous Drain Current @ V _{GS} =10V, T _A =70°C		1.6		
Pulsed Drain Current	I _{DM}	30		
Continuous Body Diode Forward Current @ T _C =25°C	I _S	7.5	mJ	
Avalanche Current @ L=0.1mH	I _{AS}	3		
Avalanche Energy @ L=0.5mH	E _{AS}	2.3		
Total Power Dissipation	P _D	T _C =25°C	50	W
		T _C =100°C	20	
		T _A =25°C	3.9	
		T _A =70°C	2.5	
Operating Junction and Storage Temperature Range	T _J , T _{stg}	-55~+150	°C	

Thermal Data

Parameter	Symbol	Steady State	Unit
Thermal Resistance, Junction-to-case	R _{θJC}	2.5	°C/W
Thermal Resistance, Junction-to-ambient	R _{θJA}	32	

Note:

- *a. The power dissipation P_D is based on T_{J(MAX)}=150°C, using junction-to-case thermal resistance, and is more useful in setting the upper dissipation limit for cases where additional heatsinking is used.
- *b. The value of R_{θJA} is measured with the device mounted on 1 in²FR -4 board with 2 oz. copper, in a still air environment with T_A=25°C. The power dissipation P_D is based on R_{θJA} and the maximum allowed junction temperature of 150°C. The value in any given application depends on the user's specific board design.
- *c. Repetitive rating, pulse width limited by junction temperature T_{J(MAX)}=150°C. Ratings are based on low frequency and low duty cycles to keep initial T_J=25°C.

Electrical Characteristics (T_A=25°C, unless otherwise specified)

Symbol	Min.	Typ.	Max.	Unit	Test Conditions
Static					
BV _{DSS}	200	-	-	V	V _{GS} =0V, I _D =250μA
V _{GS(th)}	1	-	2.5		V _{DS} =V _{GS} , I _D =250μA
G _{FS}	-	5.4	-	S	V _{DS} =10V, I _D =2A
I _{GSS}	-	-	±100	nA	V _{GS} =±20V, V _{DS} =0V
I _{DSS}	-	-	1	μA	V _{DS} =160V, V _{GS} =0V
R _{DS(ON)}	-	302	380	mΩ	V _{GS} =10V, I _D =2A
		303	395		V _{GS} =4.5V, I _D =2A
Dynamic					
C _{iss}	-	630	-	pF	V _{DS} =100V, V _{GS} =0V, f=1MHz
C _{oss}	-	65	-		
C _{rss}	-	12	-		
R _g	-	1.8	-	Ω	f=1MHz
Q _g *1, 2	-	15	-	nC	V _{DS} =100V, I _D =2A, V _{GS} =10V
Q _{gs} *1, 2	-	2	-		
Q _{gd} *1, 2	-	4	-		
t _{d(ON)} *1, 2	-	9	-	ns	V _{DS} =100V, I _D =2A, V _{GS} =10V, R _{GS} =1Ω
t _r *1, 2	-	17	-		
t _{d(OFF)} *1, 2	-	30	-		
t _f *1, 2	-	17	-		
Source-Drain Diode					
V _{SD} *1	-	0.79	1.2	V	I _S =2A, V _{GS} =0V
t _{rr}	-	50	-	ns	I _F =2A, dI _F /dt=100A/μs
Q _{rr}	-	100	-	nC	

Note:

*1. Pulse Test : Pulse Width ≤300μs, Duty Cycle≤2%

*2. Independent of operating temperature

Typical Characteristics

Typical Output Characteristics

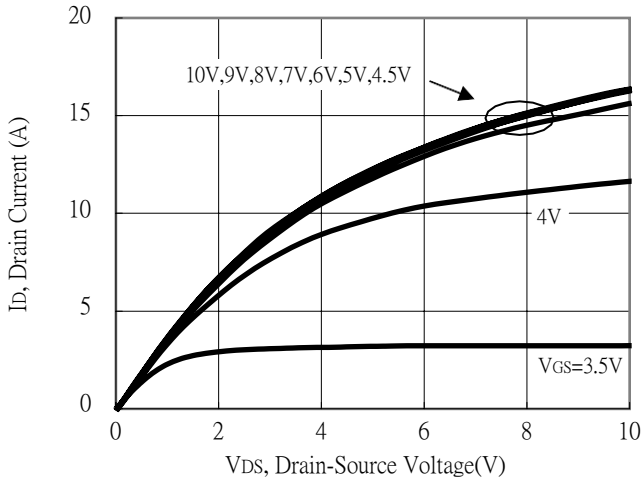

Breakdown Voltage vs Ambient Temperature

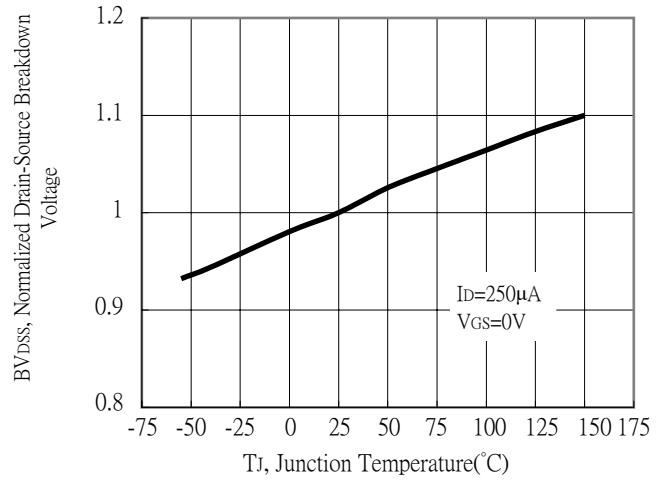

Static Drain-Source On-State resistance vs Drain Current

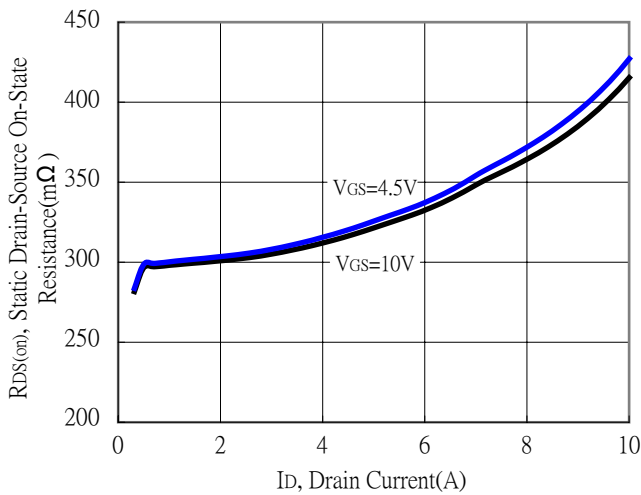

Body Diode Current vs Source-Drain Voltage

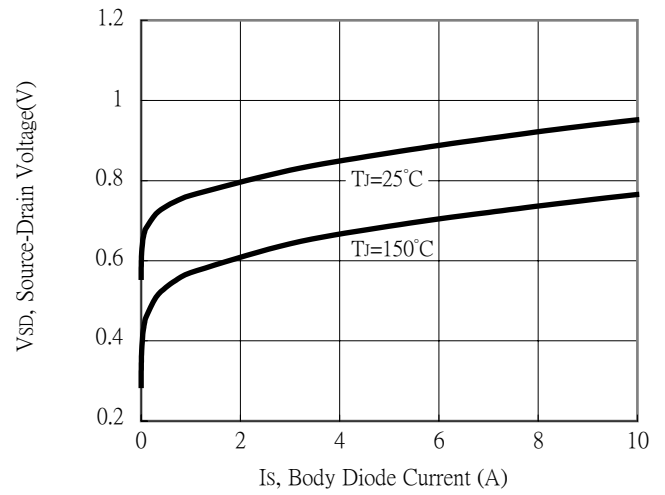

Static Drain-Source On-State Resistance vs Gate-Source Voltage

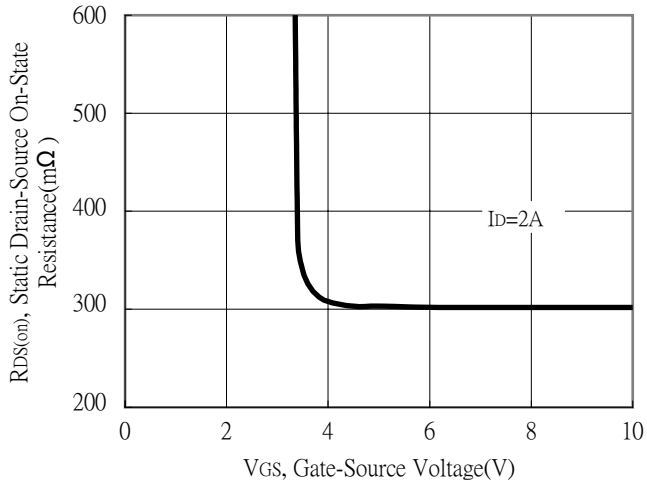

Drain-Source On-State Resistance vs Junction Temperature

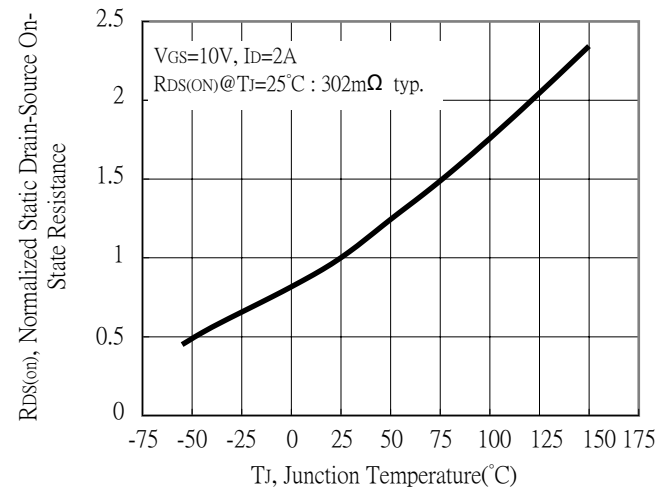

Typical Characteristics (Cont.)

Capacitance vs Drain-to-Source Voltage

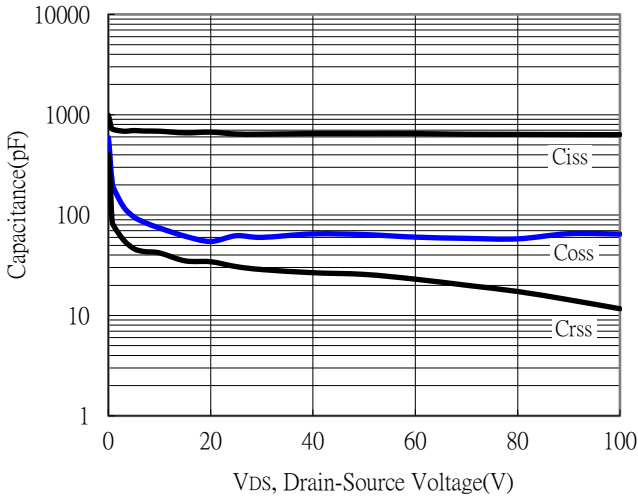

Threshold Voltage vs Junction Temperature

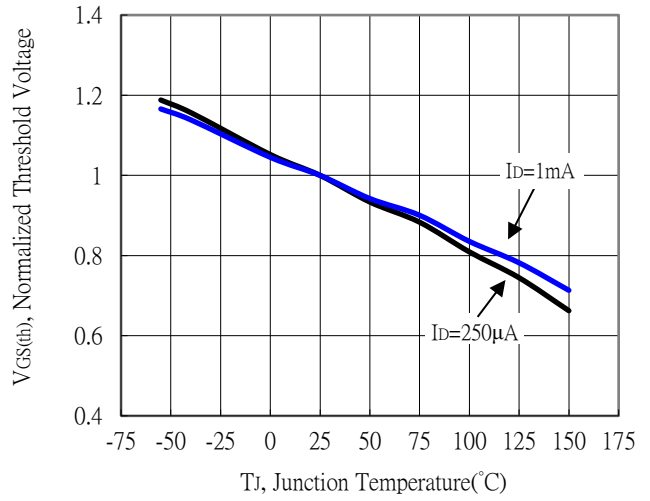

Forward Transfer Admittance vs Drain Current

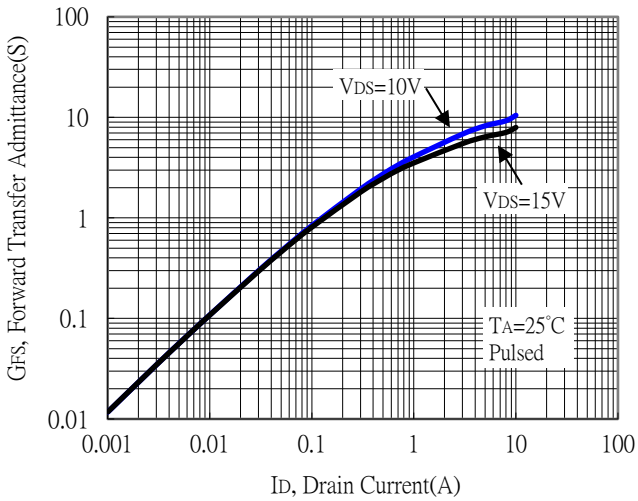

Gate Charge Characteristics

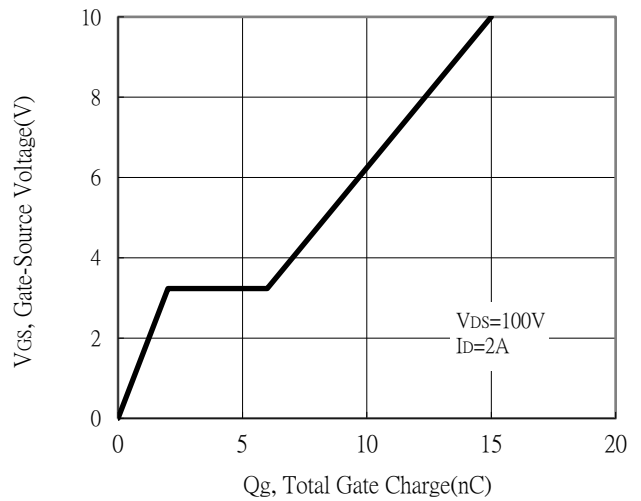

Maximum Safe Operating Area

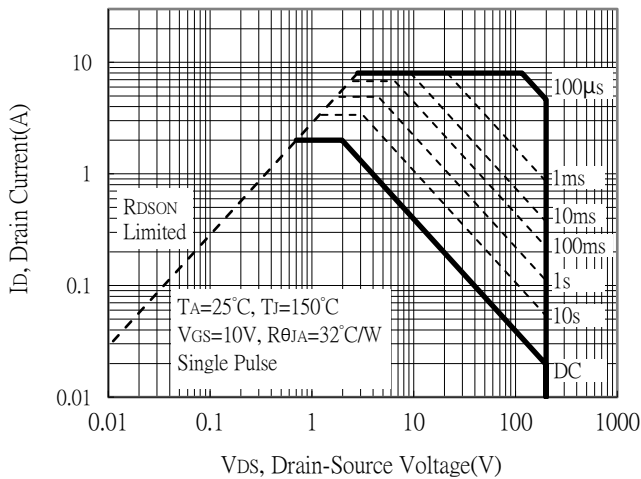

Maximum Drain Current vs Junction Temperature

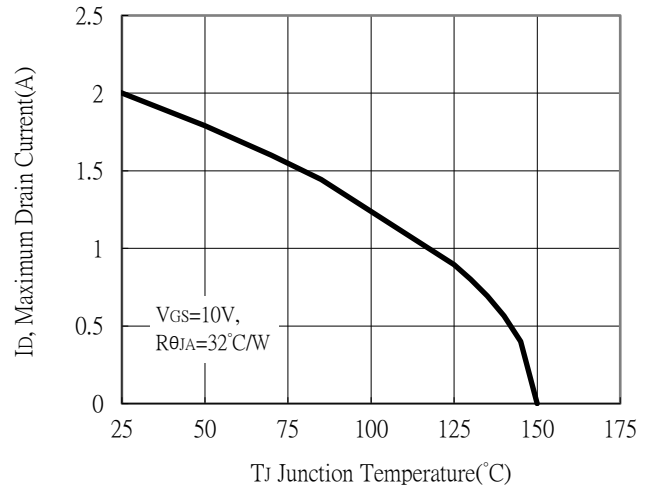

Typical Characteristics (Cont.)

Single Pulse Power Rating, Junction to Ambient

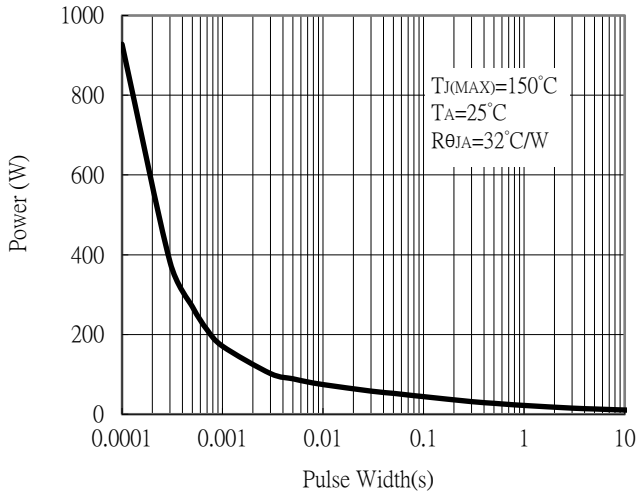

Transient Thermal Response Curves

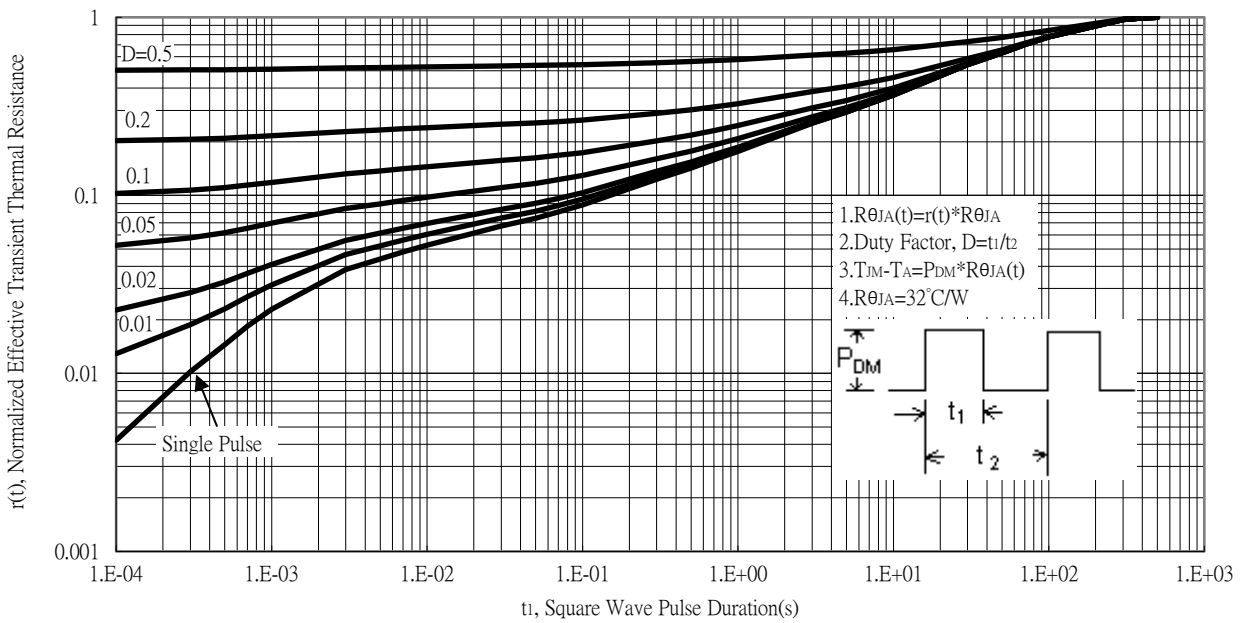

Recommended soldering footprint

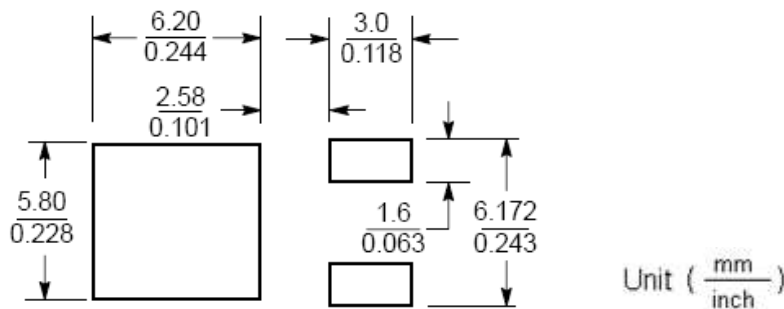

Reel Dimension

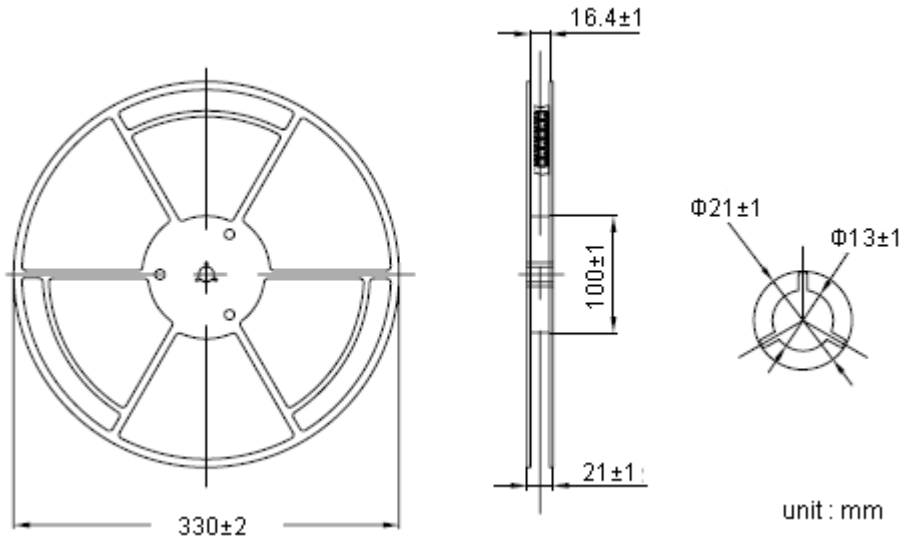

Carrier Tape Dimension

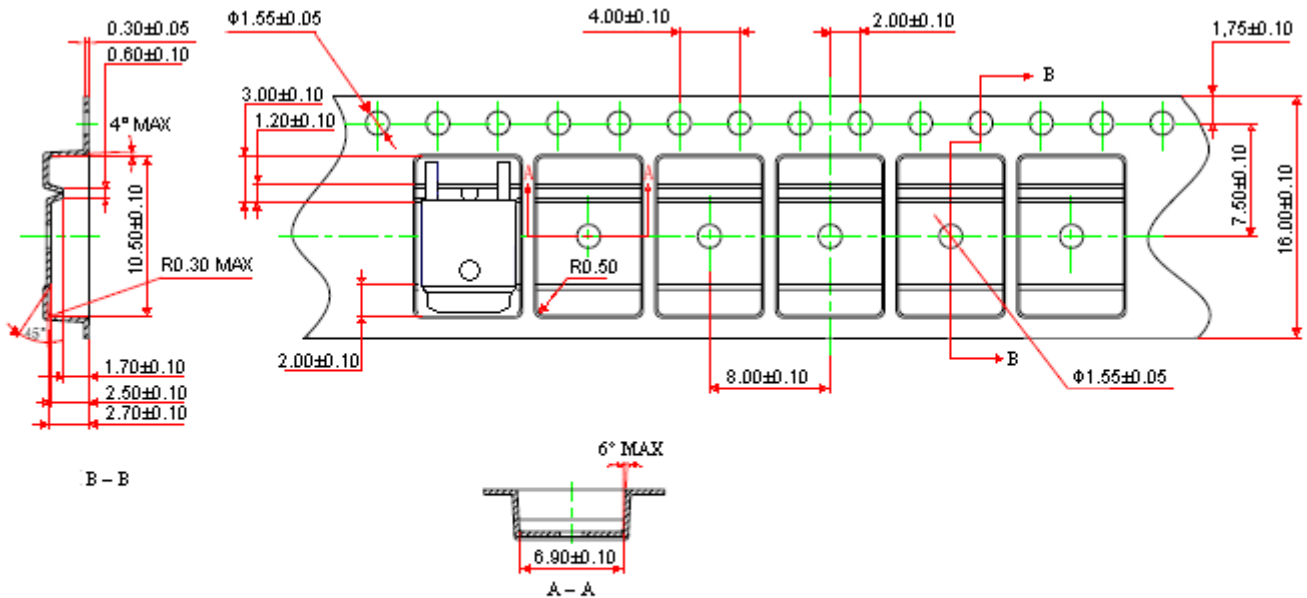

Notes:

1. 10 sprocket hole pitch cumulative tolerance ± 0.2 .
2. Camber not to exceed 1mm in 100mm.
3. Material: conductive black polystyrene, antistatic coated : $10^5 \Omega/\square \sim 10^{11} \Omega/\square$

unit : mm

TO-252 Dimension

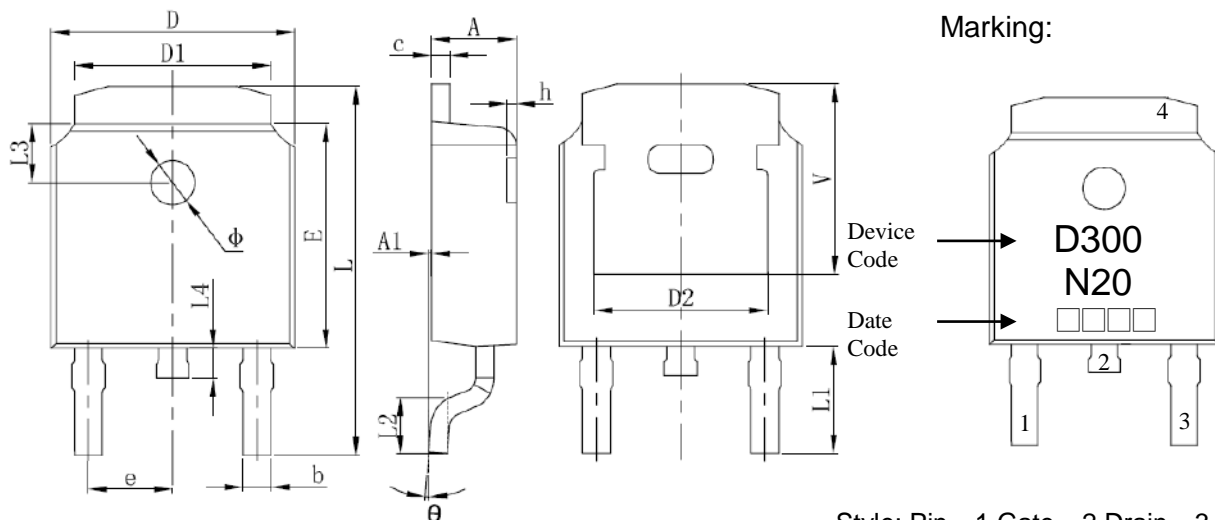

Style: Pin 1.Gate 2.Drain 3.Source 4.Drain

3-Lead TO-252 Plastic Surface Mount Package

Date Code(counting from left to right) :
 1st code: year code, the last digit of Christian year
 2nd code : month code, Jan→A, Feb→B, Mar→C, Apr→D
 May→E, Jun→F, Jul→G, Aug→H, Sep→J,
 Oct→K, Nov→L, Dec→M
 3rd and 4th codes : production serial number, 01~99

DIM	Inches		Millimeters		DIM	Inches		Millimeters	
	Min.	Max.	Min.	Max.		Min.	Max.	Min.	Max.
A	0.087	0.094	2.200	2.400	L	0.382	0.406	9.712	10.312
A1	0.000	0.005	0.000	0.127	L1	0.114	REF	2.900	REF
b	0.025	0.030	0.635	0.770	L2	0.055	0.067	1.400	1.700
c	0.018	0.023	0.460	0.580	L3	0.063	REF	1.600	REF
D	0.256	0.264	6.500	6.700	L4	0.024	0.039	0.600	1.000
D1	0.201	0.215	5.100	5.460	Φ	0.043	0.051	1.100	1.300
D2	0.190	REF	4.830	REF	θ	0°	8°	0°	8°
E	0.236	0.244	6.000	6.200	h	0.000	0.012	0.000	0.300
e	0.086	0.094	2.186	2.386	V	0.207	REF	5.250	REF