

P-Channel Enhancement Mode Power MOSFET

Features:

- Single Drive Requirement
- Low On-resistance
- Fast switching Characteristic
- Pb-free lead plating and halogen-free package

TO-252(DPAK)



BV_{DSS}	-150V
I_D @ V_{GS}=-10V, T_C=25°C	-15A
R_{DSON}@ V_{GS}=-10V, I_D=-12A	141mΩ(typ)
R_{DSON}@ V_{GS}=-4.5V, I_D=-10A	175mΩ(typ)

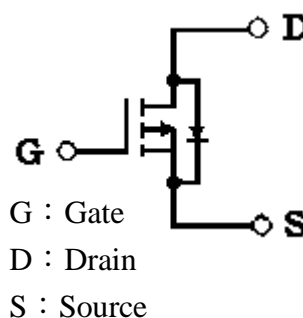

Ordering Information

Device	Package	Shipping
KJD140P15	TO-252 (Pb-free lead plating and halogen-free package)	2500 pcs / Tape & Reel

Absolute Maximum Ratings (Ta=25°C)

Parameter		Symbol	Limits	Unit
Drain-Source Voltage		V _{DS}	-150	V
Gate-Source Voltage		V _{GS}	±20	
Continuous Drain Current @ V _{GS} =-10V, T _C =25°C (Note1)		I _D	-15	A
Continuous Drain Current @ V _{GS} =-10V, T _C =100°C (Note1)			-10.6	
Continuous Drain Current @ V _{GS} =-10V, T _A =25°C (Note4)			-2.4	
Continuous Drain Current @ V _{GS} =-10V, T _A =70°C (Note4)			-1.9	
Pulsed Drain Current (Note3)		I _{DM}	-60	
Power Dissipation	T _C =25°C (Note1)	P _D	100	W
	T _C =100°C (Note1)		50	
	T _A =25°C (Note2)	P _{DSM}	2	
	T _A =70°C (Note2)		1.3	
Single Pulse Avalanche Energy		E _{AS}	225	mJ
Single Pulse Avalanche Current		I _{AS}	-15	A
Operating Junction and Storage Temperature		T _J , T _{stg}	-55~+175	°C

Thermal Data

Parameter	Symbol	Value	Unit
Thermal Resistance, Junction-to-case, max	R _{th,j-c}	1.5	°C/W
Thermal Resistance, Junction-to-ambient, max (Note2)	R _{th,j-a}	62.5	
Thermal Resistance, Junction-to-ambient, max (Note4)		90	

- Note : 1.The power dissipation P_D is based on T_{J(MAX)}=175°C, using junction-to-case thermal resistance, and is more useful in setting the upper dissipation limit for cases where additional heatsinking is used.
2. The value of R_{θJA} is measured with the device mounted on 1 in² FR-4 board with 2 oz. copper, in a still air environment with T_A=25°C. The power dissipation P_{DSM} is based on R_{θJA} and the maximum allowed junction temperature of 150°C. The value in any given application depends on the user's specific board design.
3. Repetitive rating, pulse width limited by junction temperature T_{J(MAX)}=175°C. Ratings are based on low frequency and low duty cycles to keep initial T_J=25°C.
4. When mounted on the minimum pad size recommended (PCB mount), t≤10s.

Characteristics (Tj=25°C, unless otherwise specified)

Symbol	Min.	Typ.	Max.	Unit	Test Conditions
Static					
BV _{DSS}	-150	-	-	V	V _{GS} =0V, I _D =-250μA
ΔBV _{DSS} /ΔT _j	-	-0.12	-	V/°C	Reference to 25°C, I _D =-250μA
V _{GS(th)}	-1.5	-	-2.5	V	V _{DS} = V _{GS} , I _D =-250μA
G _{FS}	-	18	-	S	V _{DS} = -5V, I _D =-12A
I _{GSS}	-	-	±100	nA	V _{GS} =±20V
I _{DSS}	-	-	-1	μA	V _{DS} = -120V, V _{GS} = 0V
I _{DSS}	-	-	-25		V _{DS} = -120V, V _{GS} = 0V, T _j =70°C
*R _{DS(ON)}	-	141	185	mΩ	V _{GS} = -10V, I _D =-12A
*R _{DS(ON)}	-	175	230		V _{GS} = -4.5V, I _D =-10A
Dynamic					
*Q _g	-	51	-	nC	V _{DS} =-120V, I _D =-12A, V _{GS} =-10V
*Q _{gs}	-	11	-		
*Q _{gd}	-	21	-		
*t _{d(ON)}	-	14	-	ns	V _{DS} =-75V, V _{GS} =-10V, I _D =-12A , R _G =3.3Ω
*t _r	-	16	-		
*t _{d(OFF)}	-	37	-		
*t _f	-	24	-		
C _{iss}	-	2473	-	pF	V _{GS} =0V, V _{DS} =-25V, f=1MHz
C _{oss}	-	122	-		
C _{rss}	-	75	-		
R _g	-	2.9	-	Ω	f=1MHz
Source-Drain Diode					
*V _{SD}	-	-0.84	-1.2	V	I _S =-12A, V _{GS} =0V
*I _S	-	-	-15	A	
*t _{rr}	-	70	-	ns	I _F =-12A, V _{GS} =0V, dI _F /dt=-100A/μs
*Q _{rr}	-	245	-	nC	

*Pulse Test : Pulse Width ≤300μs, Duty Cycle≤2%

Recommended soldering footprint

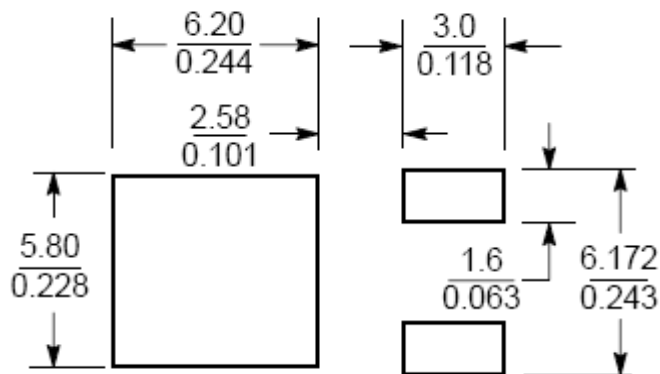

Unit ($\frac{\text{mm}}{\text{inch}}$)

Typical Characteristics

Typical Output Characteristics

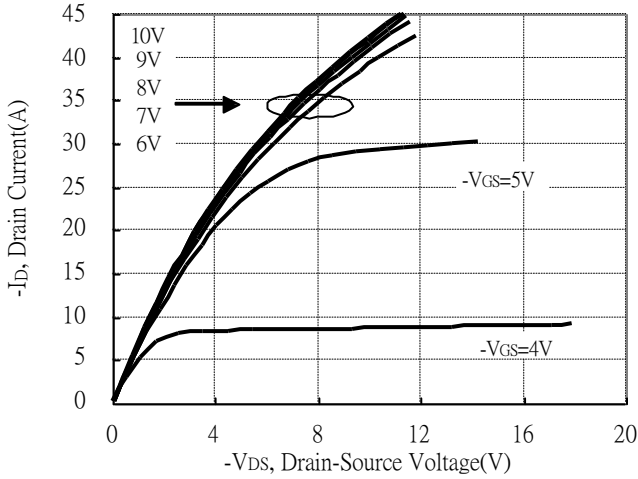

Brekdown Voltage vs Ambient Temperature

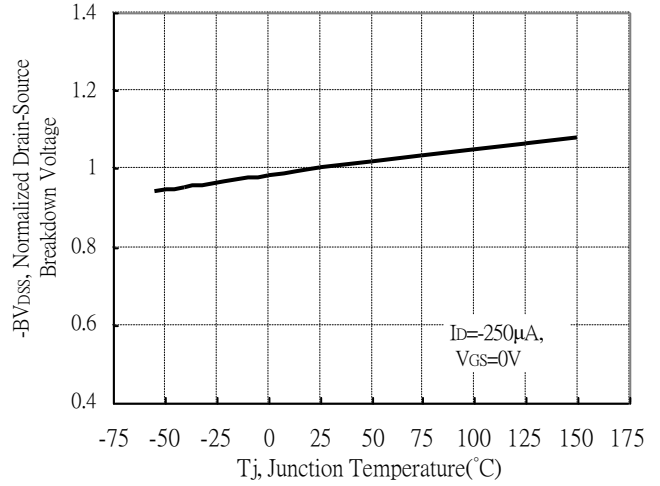

Static Drain-Source On-State resistance vs Drain Current

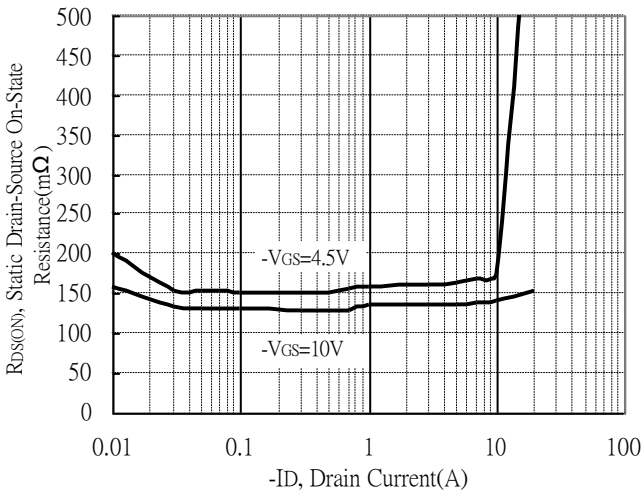

Reverse Drain Current vs Source-Drain Voltage

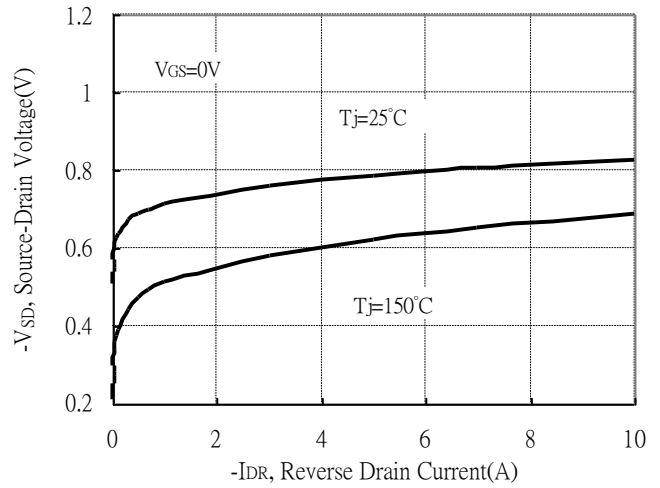

Static Drain-Source On-State Resistance vs Gate-Source Voltage

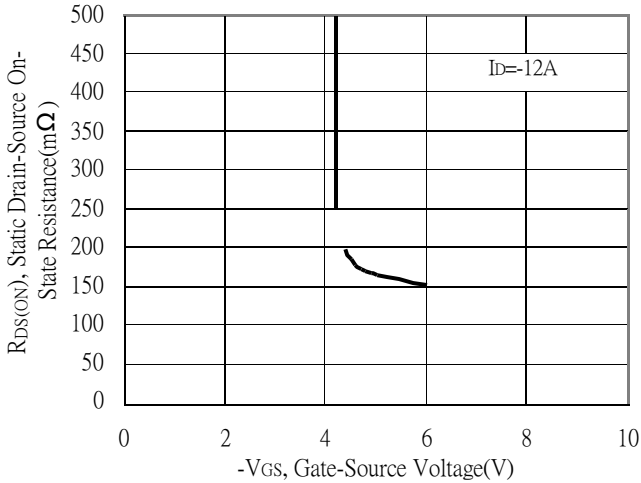

Drain-Source On-State Resistance vs Junction Temperature

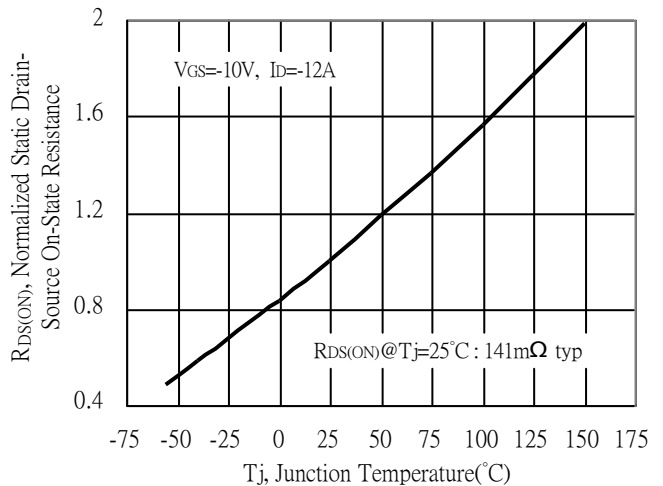

Typical Characteristics(Cont.)

Capacitance vs Drain-to-Source Voltage

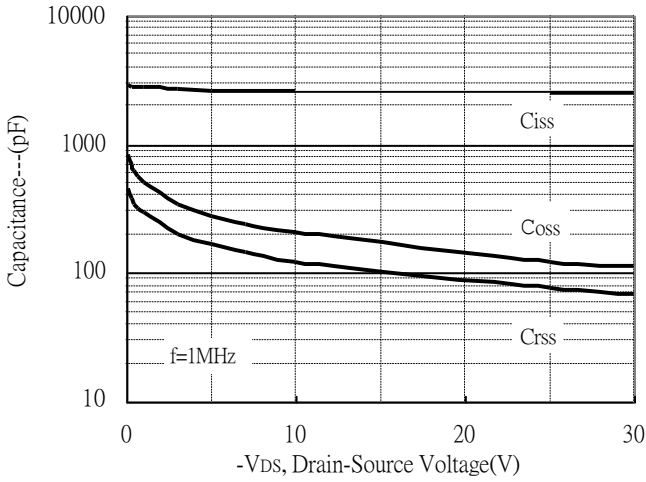

Threshold Voltage vs Junction Temperature

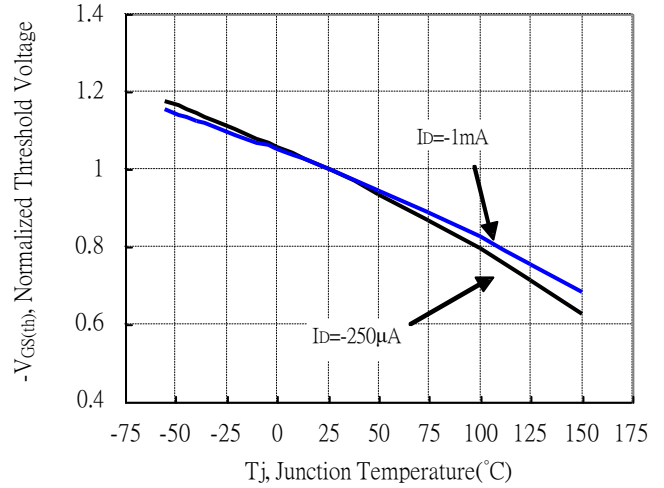

Forward Transfer Admittance vs Drain Current

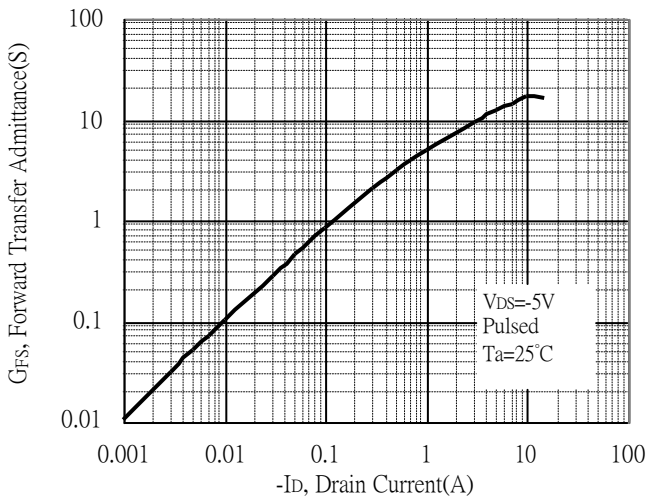

Gate Charge Characteristics

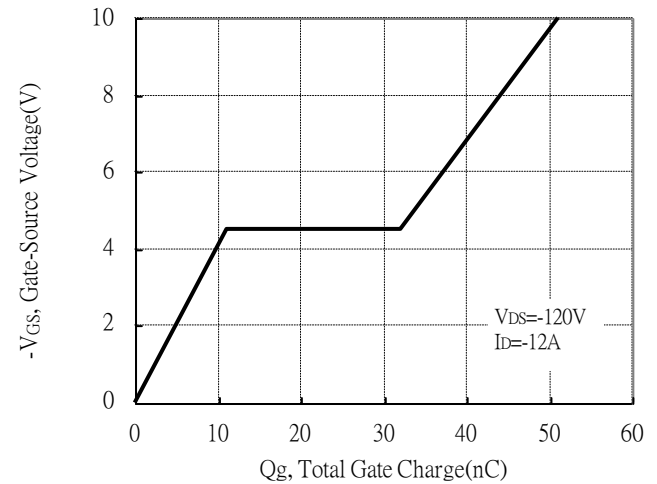

Maximum Safe Operating Area

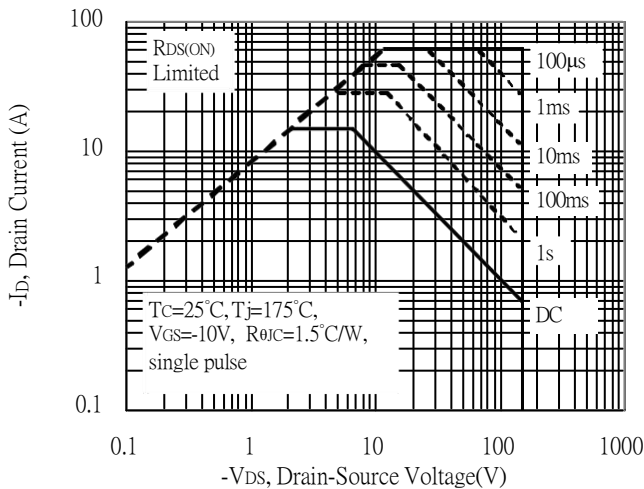

Maximum Drain Current vs Case Temperature

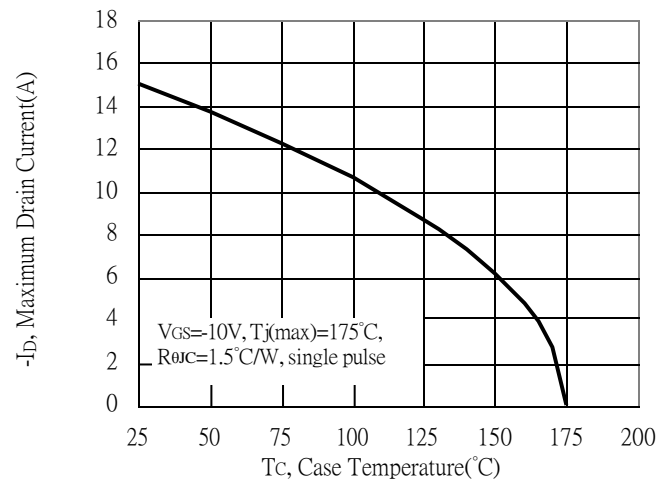

Typical Characteristics(Cont.)

Single Pulse Power Rating, Junction to Case

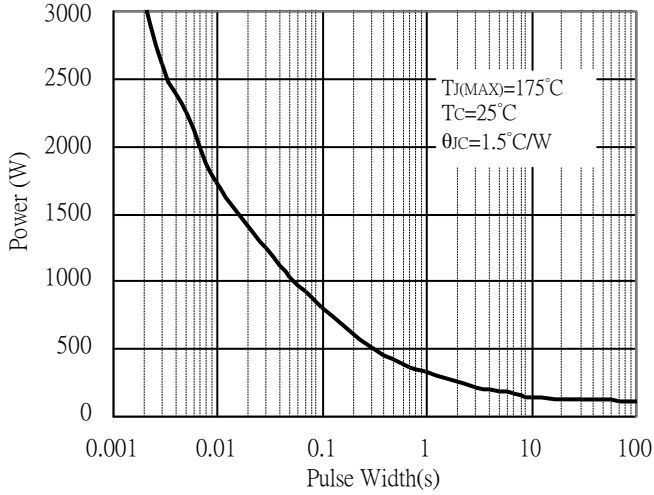

Typical Transfer Characteristics

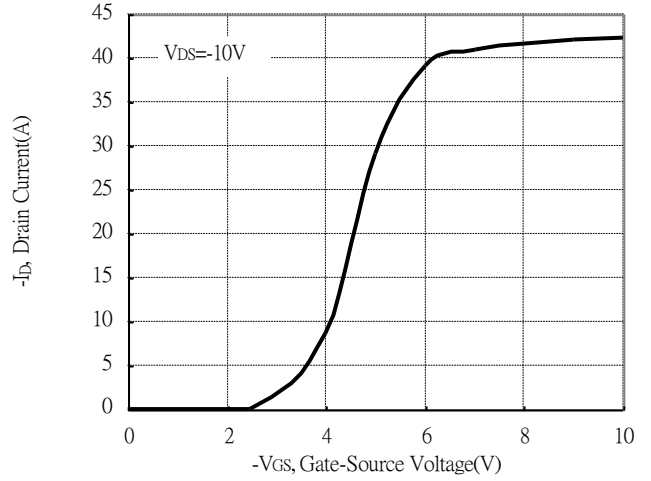

Power Derating Curve

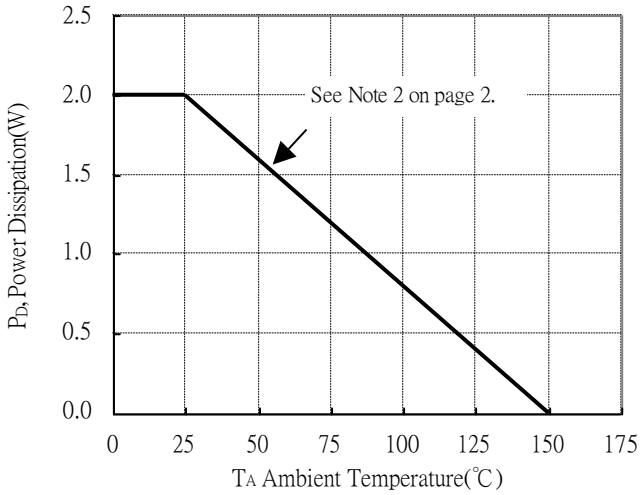

Transient Thermal Response Curves

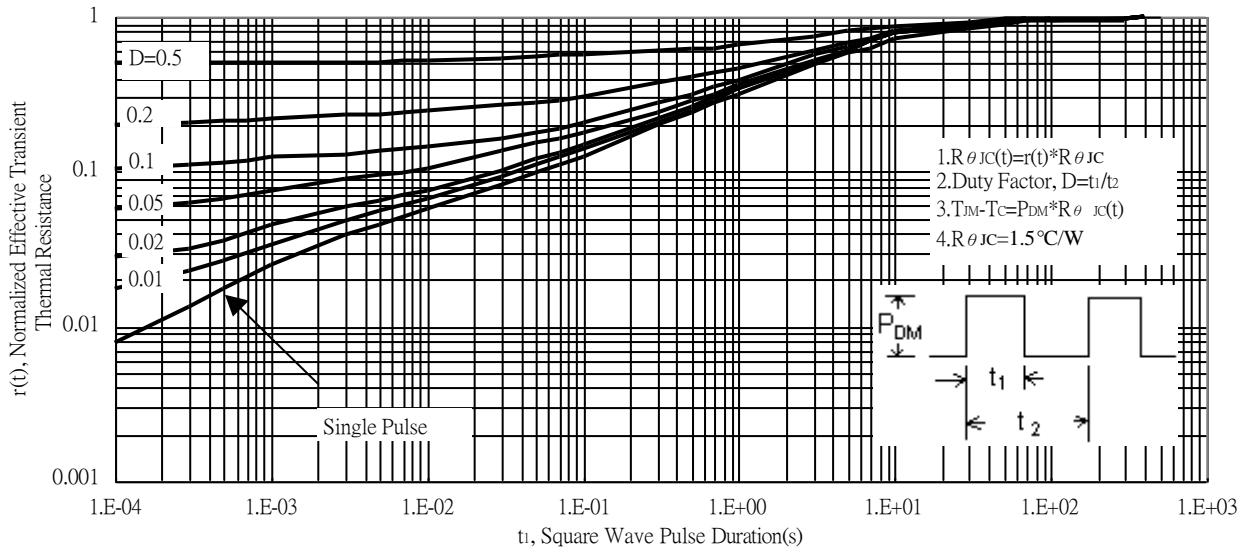

Reel Dimension

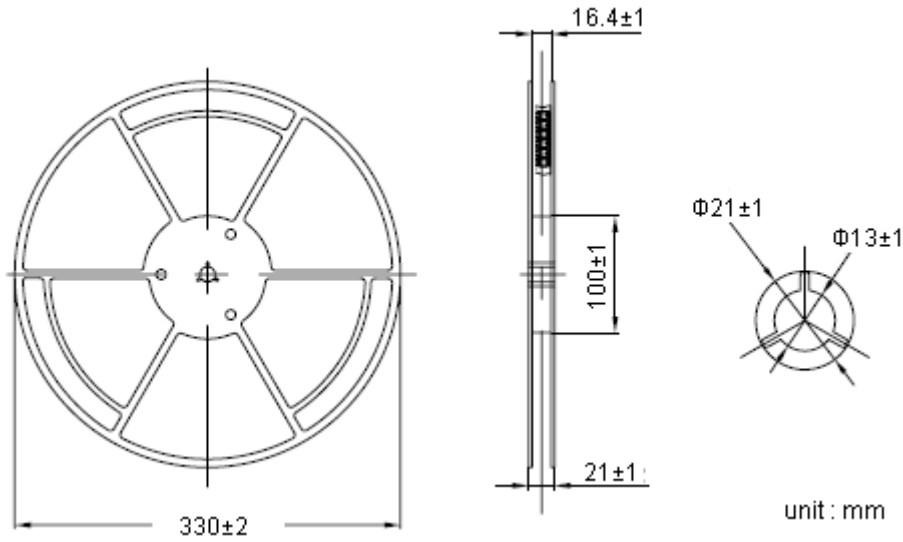

Carrier Tape Dimension

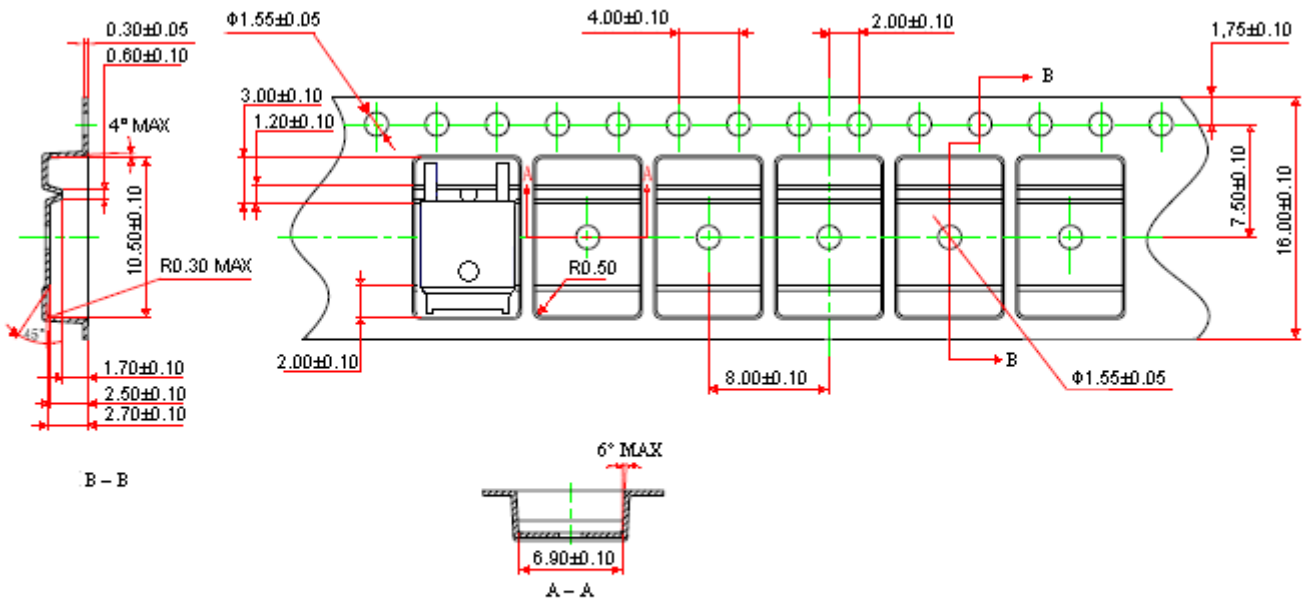

Notes:

1. 10 sprocket hole pitch cumulative tolerance ± 0.2 .
2. Camber not to exceed 1mm in 100mm.
3. Material: conductive black polystyrene, antistatic coated : $10^5 \Omega/\square \sim 10^{11} \Omega/\square$

unit : mm

TO-252 Dimension

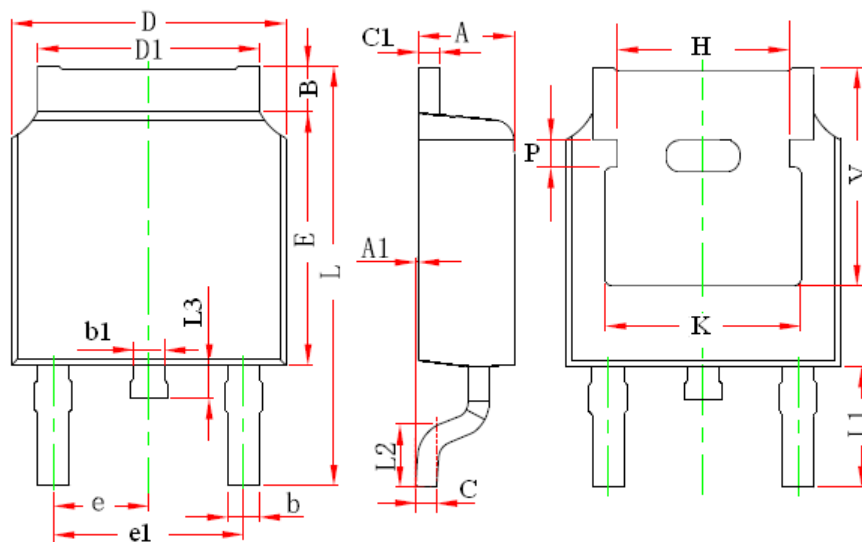

Marking:

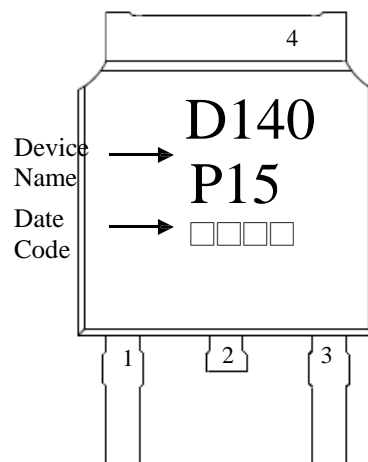

3-Lead TO-252 Plastic Surface Mount Package
 Package Code: J3

Style: Pin 1.Gate 2.Drain 3.Source
 4.Drain

DIM	Inches		Millimeters		DIM	Inches		Millimeters	
	Min.	Max.	Min.	Max.		Min.	Max.	Min.	Max.
A	0.087	0.094	2.200	2.400	e	0.086	0.094	2.186	2.386
A1	0.000	0.005	0.000	0.127	e1	0.172	0.188	4.372	4.772
B	0.039	0.048	0.990	1.210	H	0.163	REF	4.140	REF
b	0.026	0.034	0.660	0.860	K	0.190	REF	4.830	REF
b1	0.026	0.034	0.660	0.860	L	0.386	0.409	9.800	10.400
C	0.018	0.023	0.460	0.580	L1	0.114	REF	2.900	REF
C1	0.018	0.023	0.460	0.580	L2	0.055	0.067	1.400	1.700
D	0.256	0.264	6.500	6.700	L3	0.024	0.039	0.600	1.000
D1	0.201	0.215	5.100	5.460	P	0.026	REF	0.650	REF
E	0.236	0.244	6.000	6.200	V	0.211	REF	5.350	REF