

## P-Channel Enhancement Mode Power MOSFET

### Features:

- Low On Resistance
- Low Gate Charge
- Fast Switching Characteristic

TO-252

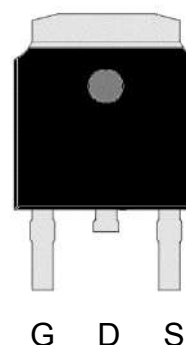

$BV_{DSS}$	-60V
$I_D @ V_{GS} = -10V, T_C = 25^\circ C$	-11.4A
$I_D @ V_{GS} = -10V, T_A = 25^\circ C$	-3.8A
$R_{DS(ON)}$ typ. @ $V_{GS} = -10V, I_D = -5A$	84m $\Omega$
$R_{DS(ON)}$ typ. @ $V_{GS} = -5V, I_D = -3A$	113m $\Omega$

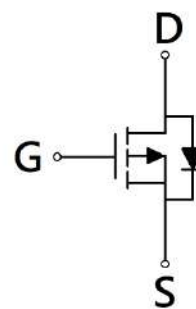

G : Gate S : Source D : Drain

### Ordering Information

Device	Package	Shipping
KJD080P06	TO-252 (Pb-free lead plating and halogen-free package)	2500 pcs / Tape & Reel

### Absolute Maximum Ratings (T<sub>A</sub>=25°C)

Parameter	Symbol	Limits	Unit	
Drain-Source Voltage	V <sub>DS</sub>	-60	V	
Gate-Source Voltage	V <sub>GS</sub>	±20		
Continuous Drain Current @ V <sub>GS</sub> =-10V, T <sub>C</sub> =25°C	I <sub>D</sub>	-11.4	A	
Continuous Drain Current @ V <sub>GS</sub> =-10V, T <sub>C</sub> =100°C		-7.2		
Continuous Drain Current @ V <sub>GS</sub> =-10V, T <sub>A</sub> =25°C		-3.8		
Continuous Drain Current @ V <sub>GS</sub> =-10V, T <sub>A</sub> =70°C		-3		
Pulsed Drain Current	I <sub>DM</sub>	-45.6		
Continuous Body Diode Forward Current @ T <sub>C</sub> =25°C	I <sub>S</sub>	-11.4		
Avalanche Current @ L=0.1mH	I <sub>AS</sub>	-6		
Avalanche Energy @ L=0.5mH	E <sub>AS</sub>	12	mJ	
Total Power Dissipation	P <sub>D</sub>	T <sub>C</sub> =25°C	28	W
		T <sub>C</sub> =100°C	11	
		T <sub>A</sub> =25°C	3	
		T <sub>A</sub> =70°C	1.9	
Operating Junction and Storage Temperature Range	T <sub>J</sub> , T <sub>stg</sub>	-55~+150	°C	

### Thermal Data

Parameter	Symbol	Steady State	Unit
Thermal Resistance, Junction-to-case	R <sub>θJC</sub>	4.5	°C/W
Thermal Resistance, Junction-to-ambient	R <sub>θJA</sub>	41	

Note:

- \*a. The power dissipation P<sub>D</sub> is based on T<sub>J(MAX)</sub>=150°C, using junction-to-case thermal resistance, and is more useful in setting the upper dissipation limit for cases where additional heatsinking is used.
- \*b. The value of R<sub>θJA</sub> is measured with the device mounted on 1 in<sup>2</sup> FR-4 board with 2 oz. copper, in a still air environment with T<sub>A</sub>=25°C. The power dissipation P<sub>D</sub> is based on R<sub>θJA</sub> and the maximum allowed junction temperature of 150°C. The value in any given application depends on the user's specific board design.
- \*c. Repetitive rating, pulse width limited by junction temperature T<sub>J(MAX)</sub>=150°C. Ratings are based on low frequency and low duty cycles to keep initial T<sub>J</sub>=25°C.

**Electrical Characteristics (T<sub>A</sub>=25°C, unless otherwise specified)**

Symbol	Min.	Typ.	Max.	Unit	Test Conditions
<b>Static</b>					
BV <sub>DSS</sub>	-60	-	-	V	V <sub>GS</sub> =0V, I <sub>D</sub> =-250μA
V <sub>GS(th)</sub>	-1.5	-	-3		V <sub>DS</sub> =V <sub>GS</sub> , I <sub>D</sub> =-250μA
G <sub>FS</sub>	-	7.6	-	S	V <sub>DS</sub> =-10V, I <sub>D</sub> =-5A
I <sub>GSS</sub>	-	-	±100	nA	V <sub>GS</sub> =±20V, V <sub>DS</sub> =0V
I <sub>DSS</sub>	-	-	-1	μA	V <sub>DS</sub> =-48V, V <sub>GS</sub> =0V
R <sub>DS(ON)</sub>	-	84	110	mΩ	V <sub>GS</sub> =-10V, I <sub>D</sub> =-5A
	-	113	150		V <sub>GS</sub> =-5V, I <sub>D</sub> =-3A
<b>Dynamic</b>					
C <sub>iss</sub>	-	533	-	pF	V <sub>DS</sub> =-30V, V <sub>GS</sub> =0V, f=1MHz
C <sub>oss</sub>	-	58	-		
C <sub>rss</sub>	-	43	-		
R <sub>g</sub>	-	4.1	-	Ω	f=1MHz
Q <sub>g</sub> *1, 2	-	11	-	nC	V <sub>DS</sub> =-30V, I <sub>D</sub> =-5A, V <sub>GS</sub> =-10V
Q <sub>gs</sub> *1, 2	-	2.2	-		
Q <sub>gd</sub> *1, 2	-	2.6	-		
t <sub>d(ON)</sub> *1, 2	-	7.4	-	ns	V <sub>DS</sub> =-30V, I <sub>D</sub> =-5A, V <sub>GS</sub> =-10V, R <sub>GS</sub> =3Ω
t <sub>r</sub> *1, 2	-	17	-		
t <sub>d(OFF)</sub> *1, 2	-	23	-		
t <sub>f</sub> *1, 2	-	7.4	-		
<b>Source-Drain Diode</b>					
V <sub>SD</sub> *1	-	-0.89	-1.2	V	I <sub>S</sub> =-5A, V <sub>GS</sub> =0V
t <sub>rr</sub>	-	11	-	ns	I <sub>F</sub> =-5A, dI <sub>F</sub> /dt=100A/μs
Q <sub>rr</sub>	-	7.6	-	nC	

Note:

\*1. Pulse Test : Pulse Width ≤300μs, Duty Cycle≤2%

\*2. Independent of operating temperature

## Typical Characteristics

Typical Output Characteristics

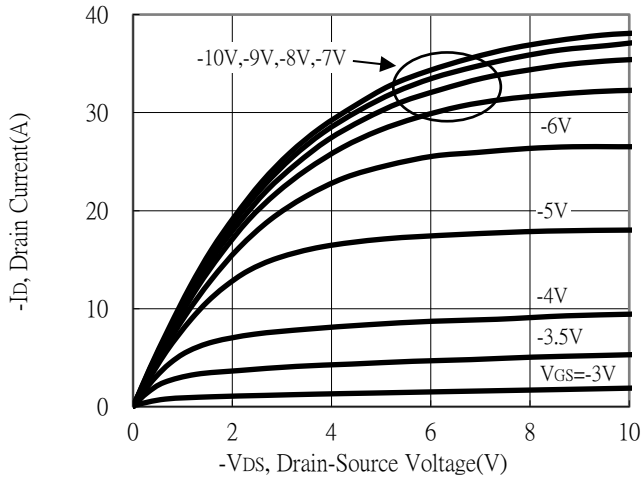

Breakdown Voltage vs Ambient Temperature

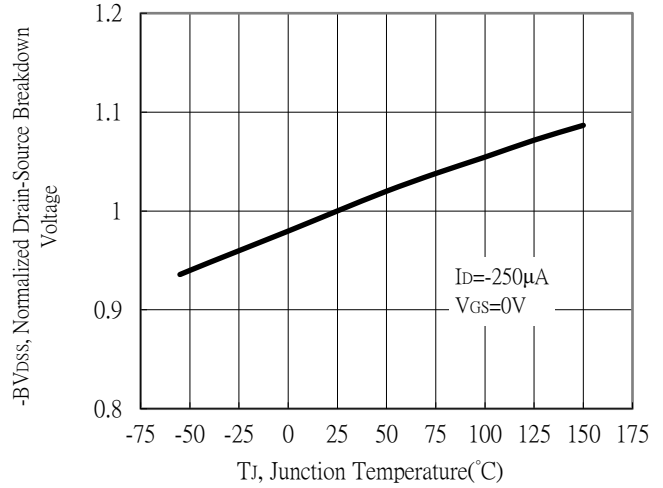

Static Drain-Source On-State resistance vs Drain Current

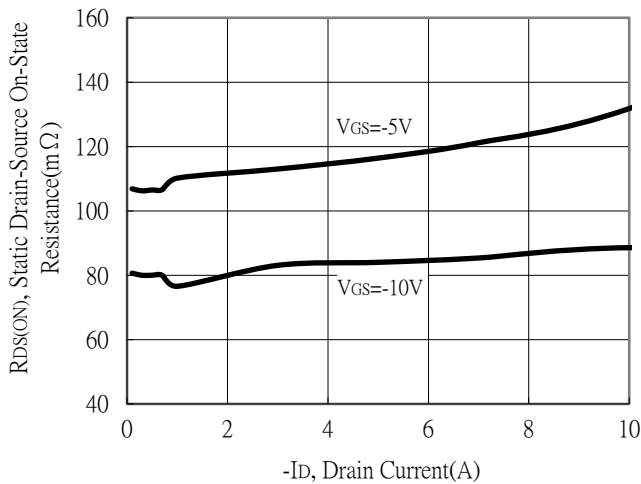

Body Diode Current vs Source-Drain Voltage

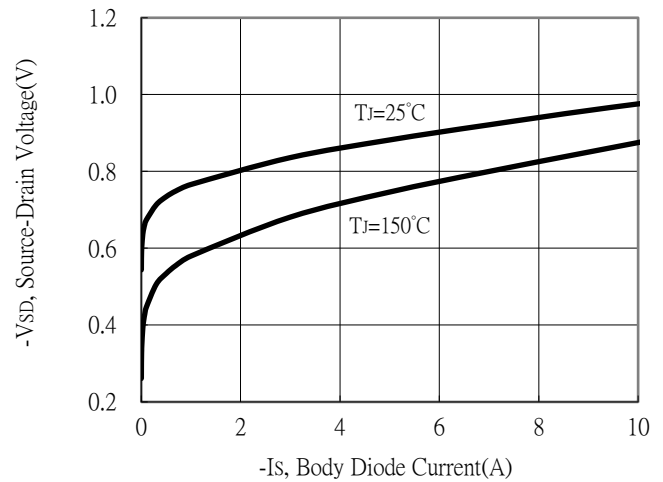

Static Drain-Source On-State Resistance vs Gate-Source Voltage

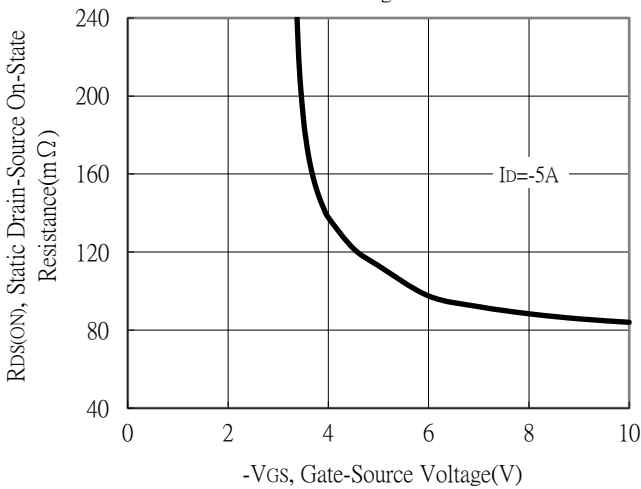

Drain-Source On-State Resistance vs Junction Temperature

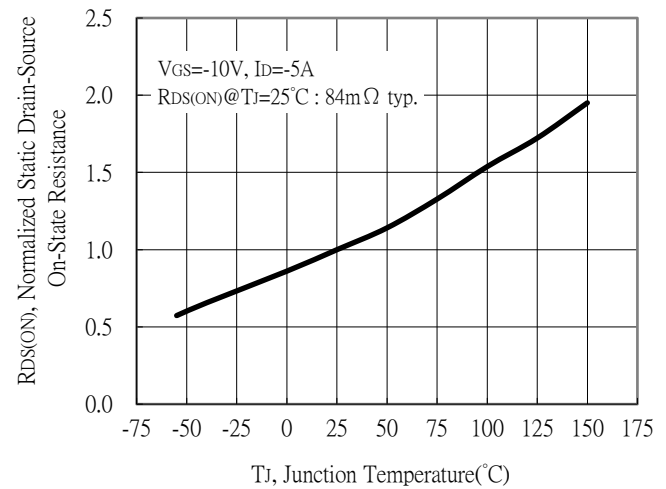

**Typical Characteristics (Cont.)**

Capacitance vs Drain-to-Source Voltage

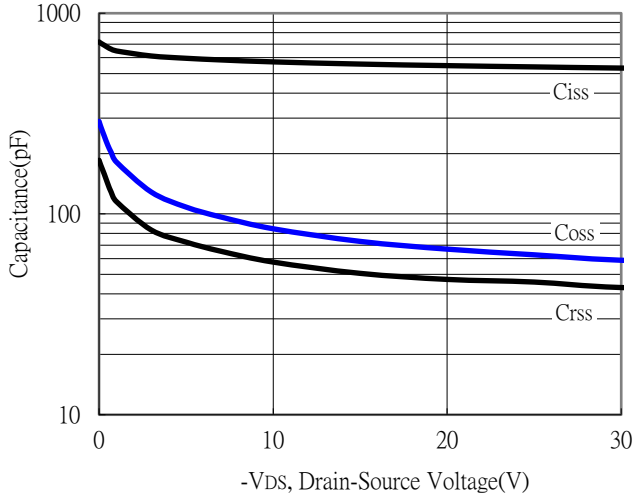

Threshold Voltage vs Junction Temperature

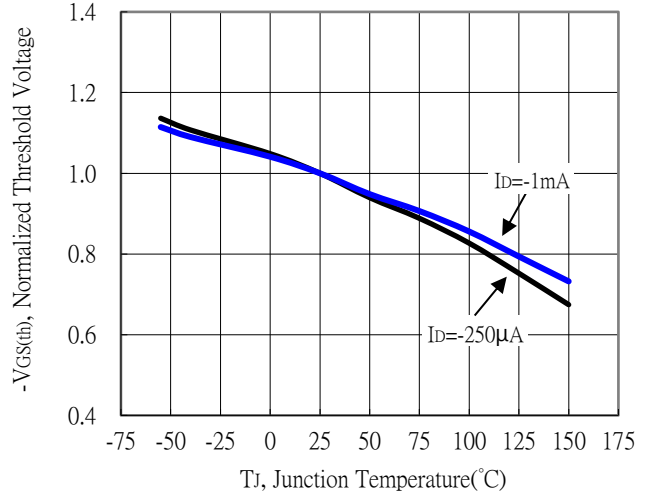

Forward Transfer Admittance vs Drain Current

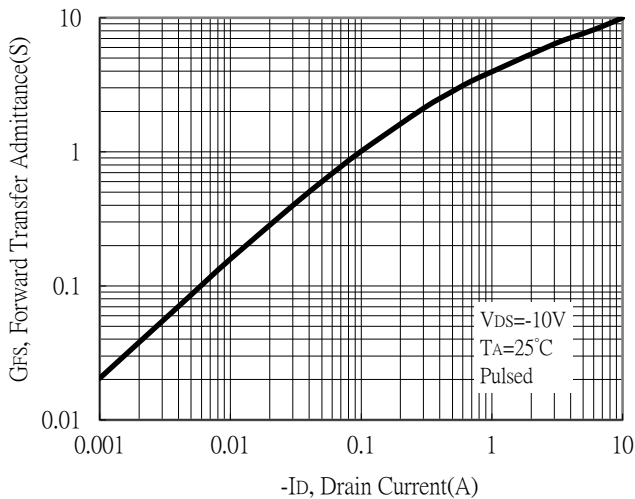

Gate Charge Characteristics

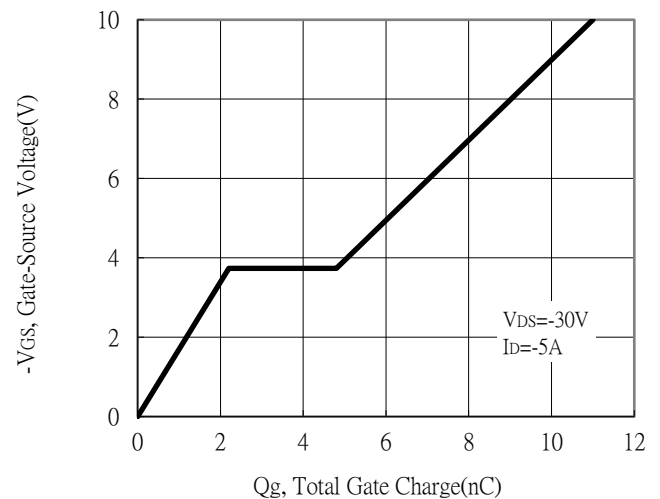

Maximum Safe Operating Area

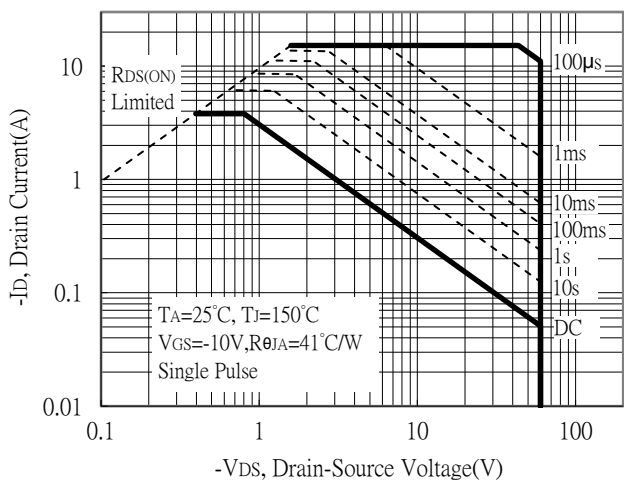

Maximum Drain Current vs Junction Temperature

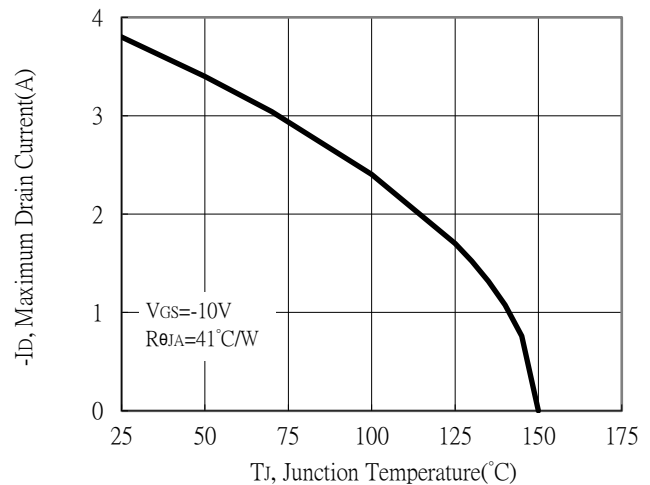

**Typical Characteristics (Cont.)**

Single Pulse Power Rating, Junction to Ambient

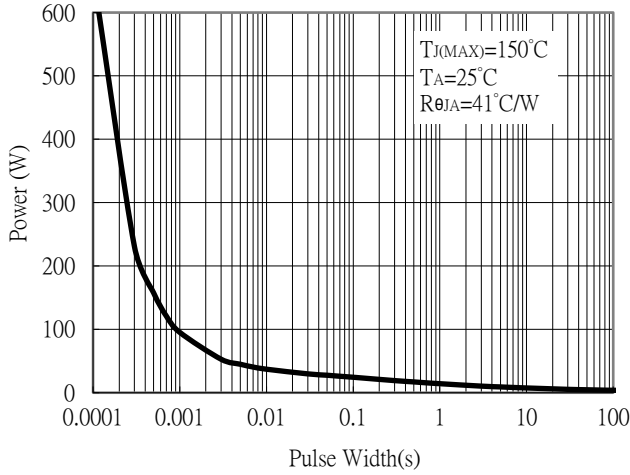

Transient Thermal Response Curves

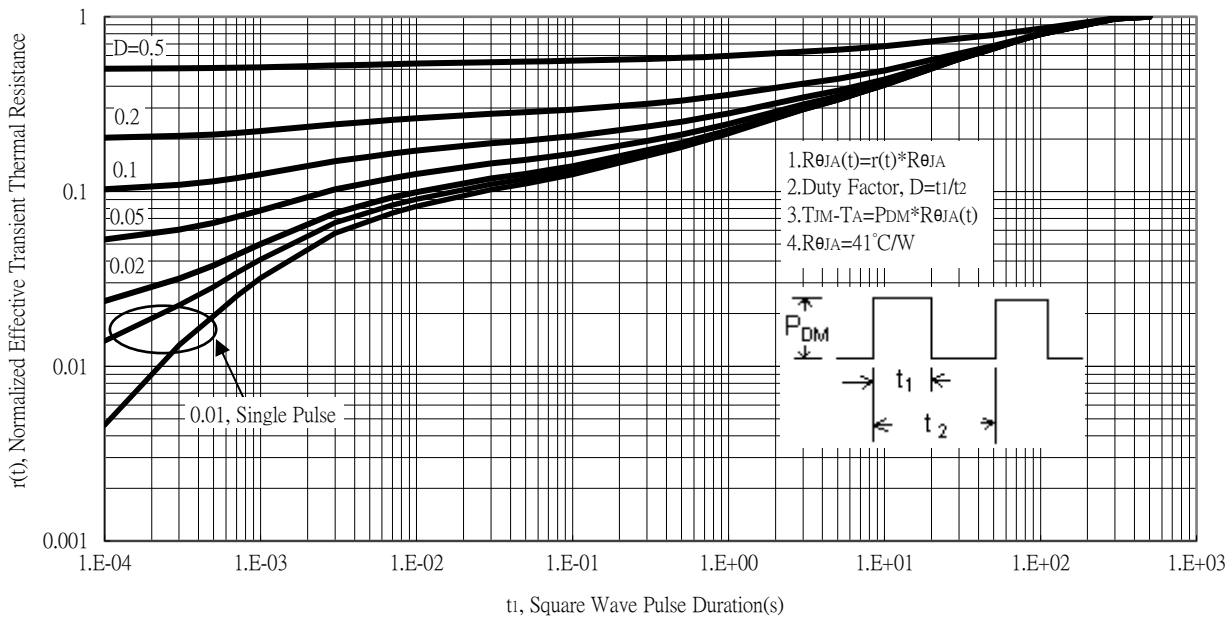

**Recommended soldering footprint**

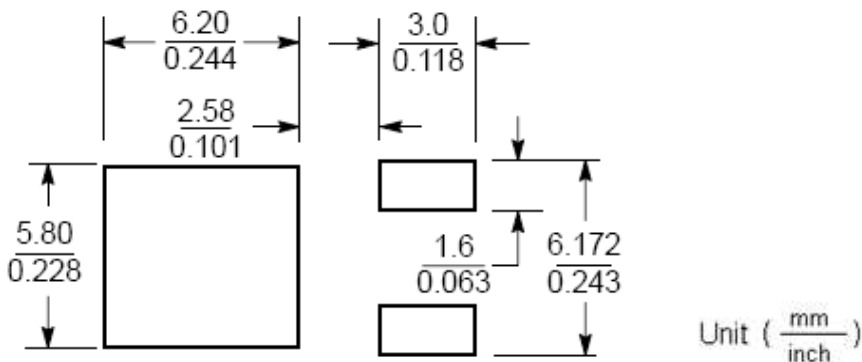

**Reel Dimension**

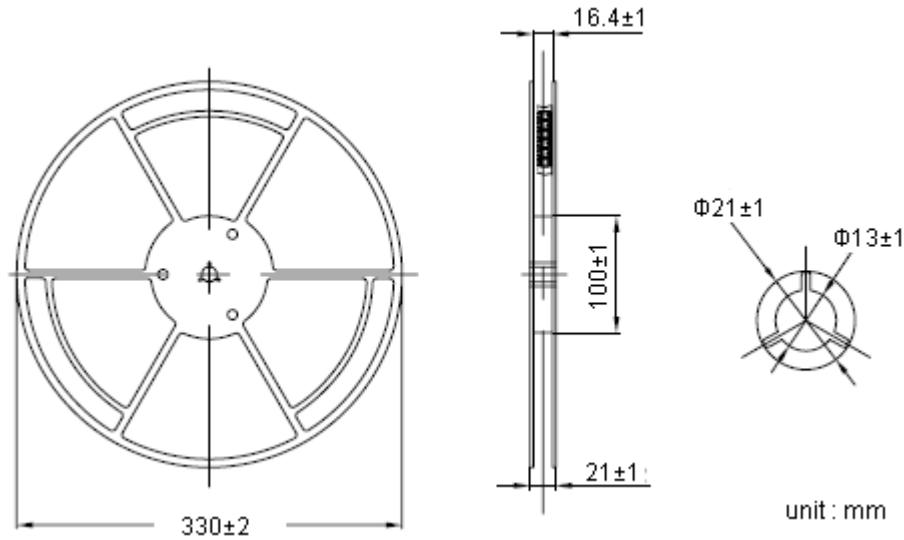

**Carrier Tape Dimension**

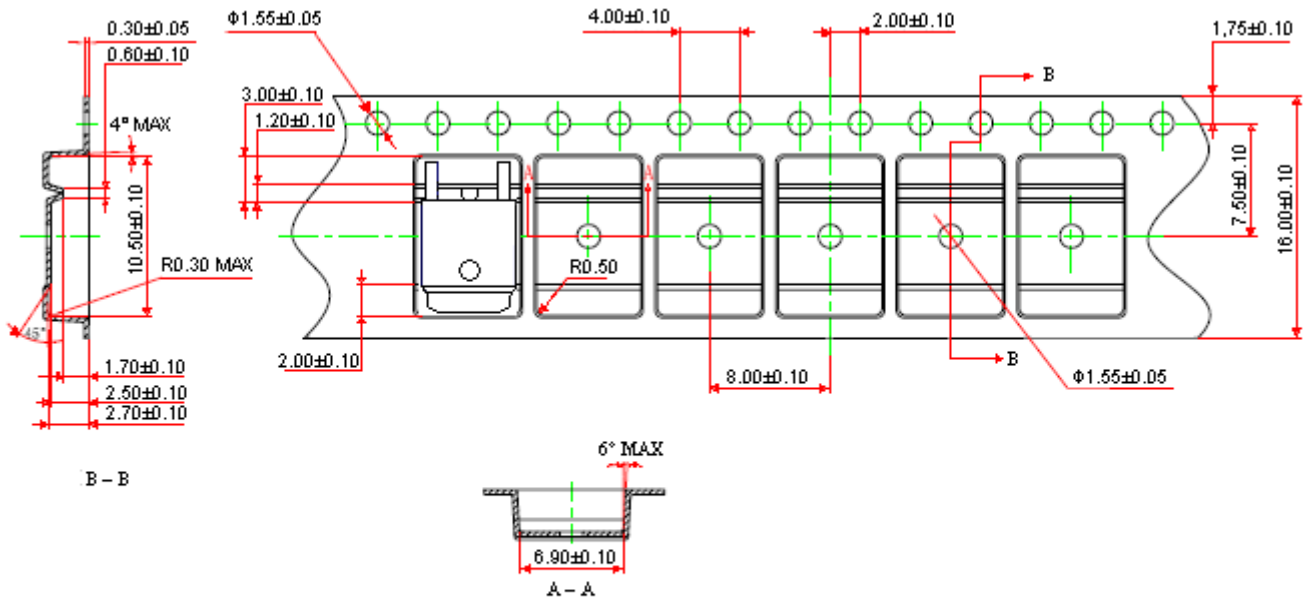

Notes:

- 1. 10 sprocket hole pitch cumulative tolerance ±0.2.
- 2. Camber not to exceed 1mm in 100mm.
- 3. Material: conductive black polystyrene, antistatic coated : 10<sup>5</sup> Ω/□~ 10<sup>11</sup> Ω/□

unit : mm

**TO-252 Dimension**

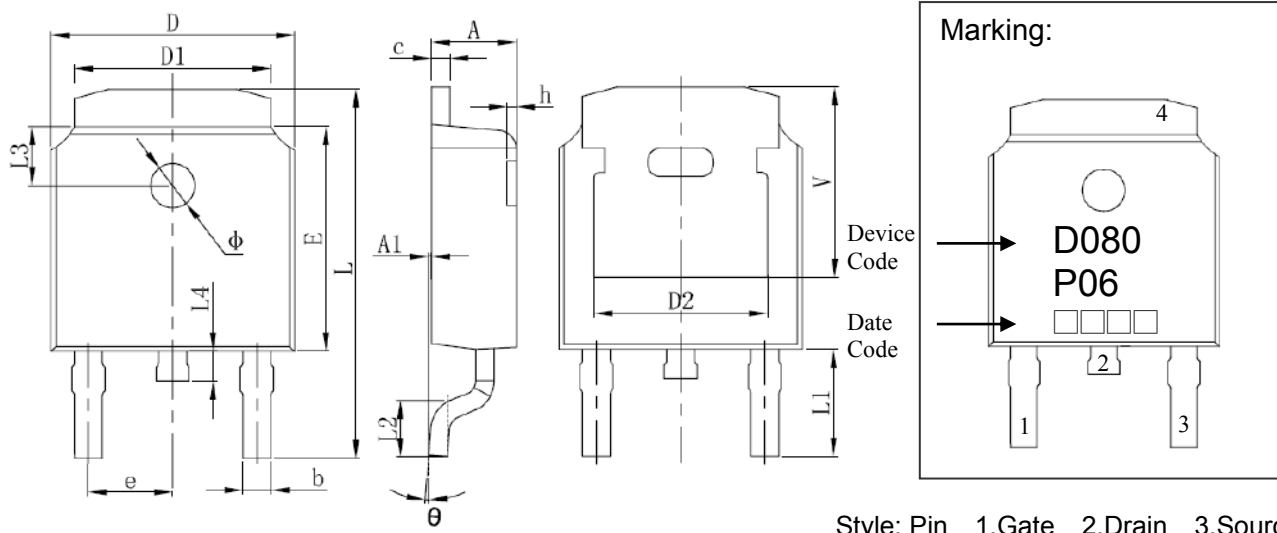

3-Lead TO-252 Plastic Surface Mount Package

Date Code(counting from left to right) :  
 1<sup>st</sup> code: year code, the last digit of Christian year  
 2<sup>nd</sup> code : month code, Jan→A, Feb→B, Mar→C,  
 Apr→D, May→E, Jun→F, Jul→G, Aug→H,  
 Sep→J, Oct→K, Nov→L, Dec→M  
 3<sup>rd</sup> and 4<sup>th</sup> codes : production serial number, 01~99

DIM	Inches		Millimeters		DIM	Inches		Millimeters	
	Min.	Max.	Min.	Max.		Min.	Max.	Min.	Max.
A	0.087	0.094	2.200	2.400	L	0.382	0.406	9.712	10.312
A1	0.000	0.005	0.000	0.127	L1	0.114	REF	2.900	REF
b	0.025	0.030	0.635	0.770	L2	0.055	0.067	1.400	1.700
c	0.018	0.023	0.460	0.580	L3	0.063	REF	1.600	REF
D	0.256	0.264	6.500	6.700	L4	0.024	0.039	0.600	1.000
D1	0.201	0.215	5.100	5.460	Φ	0.043	0.051	1.100	1.300
D2	0.190	REF	4.830	REF	θ	0°	8°	0°	8°
E	0.236	0.244	6.000	6.200	h	0.000	0.012	0.000	0.300
e	0.086	0.094	2.186	2.386	V	0.207	REF	5.250	REF