

N -Channel Logic Level Enhancement Mode Power MOSFET

Features:

- Low Gate Charge
- Simple Drive Requirement
- Pb-free lead plating and halogen-free package

TO-252(DPAK)

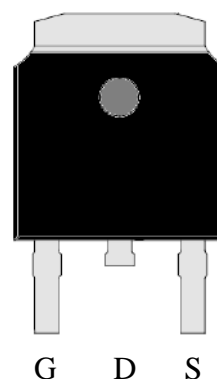

BV_{DSS}		100V
I_D		18A
$R_{DS(on)(TYP)}$	$V_{GS}=10V, I_D=18A$	60m Ω
	$V_{GS}=4.5V, I_D=12A$	59m Ω

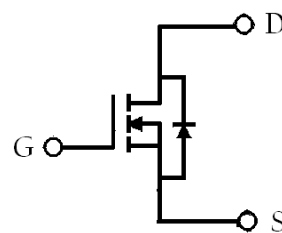

G : Gate D : Drain
 S : Source

Ordering Information

Device	Package	Shipping
KJB55N10	TO-252 (Pb-free lead plating and halogen-free package)	2500 pcs / Tape & Reel

Absolute Maximum Ratings ($T_c=25^\circ\text{C}$, unless otherwise noted)

Parameter	Symbol	Limits	Unit
Drain-Source Voltage	V_{DS}	100	V
Gate-Source Voltage	V_{GS}	± 20	
Continuous Drain Current @ $T_c=25^\circ\text{C}$	I_D	18	A
Continuous Drain Current @ $T_c=100^\circ\text{C}$		11	
Pulsed Drain Current *1	I_{DM}	40	
Avalanche Current	I_{AS}	18	
Avalanche Energy @ $L=0.1\text{mH}$, $I_D=18\text{A}$, $R_G=25\Omega$	E_{AS}	16	mJ
Repetitive Avalanche Energy @ $L=0.1\text{mH}$ (Note 2)	E_{AR}	4.6	
Total Power Dissipation @ $T_c=25^\circ\text{C}$	P_d	50	W
Total Power Dissipation @ $T_A=25^\circ\text{C}$		1.14	
Operating Junction and Storage Temperature Range	T_j, T_{stg}	$-55\sim+150$	$^\circ\text{C}$

Note : *1. Pulse width limited by maximum junction temperature
 *2. Duty cycle $\leq 1\%$

Thermal Data

Parameter	Symbol	Value	Unit
Thermal Resistance, Junction-to-case, max	$R_{th,j-c}$	2.5	$^\circ\text{C}/\text{W}$
Thermal Resistance, Junction-to-ambient, max	$R_{th,j-a}$	110	

Characteristics ($T_c=25^\circ\text{C}$, unless otherwise specified)

Symbol	Min.	Typ.	Max.	Unit	Test Conditions
Static					
BV_{DSS}	100	-	-	V	$V_{GS}=0\text{V}$, $I_D=250\mu\text{A}$
$V_{GS(th)}$	1	1.4	2.5		$V_{DS}=V_{GS}$, $I_D=250\mu\text{A}$
I_{GSS}	-	-	± 100	nA	$V_{GS}=\pm 20\text{V}$, $V_{DS}=0\text{V}$
I_{DSS}	-	-	1	μA	$V_{DS}=80\text{V}$, $V_{GS}=0\text{V}$
	-	-	25		$V_{DS}=80\text{V}$, $V_{GS}=0\text{V}$, $T_J=125^\circ\text{C}$
$R_{DS(ON)} *1$	-	60	80	m Ω	$V_{GS}=10\text{V}$, $I_D=18\text{A}$
	-	59	80		$V_{GS}=4.5\text{V}$, $I_D=12\text{A}$
$G_{FS} *1$	-	30	-	S	$V_{DS}=5\text{V}$, $I_D=18\text{A}$
Dynamic					
$Q_g *1, 2$	-	14	-	nC	$I_D=12\text{A}$, $V_{DS}=80\text{V}$, $V_{GS}=10\text{V}$
$Q_{gs} *1, 2$	-	1.7	-		
$Q_{gd} *1, 2$	-	6.6	-		
$t_{d(ON)} *1, 2$	-	7	-	ns	$V_{DS}=50\text{V}$, $I_D=12\text{A}$, $V_{GS}=10\text{V}$, $R_G=6\Omega$
$t_r *1, 2$	-	5	-		
$t_{d(OFF)} *1, 2$	-	27	-		
$t_f *1, 2$	-	13	-		

Ciss	-	662	-	pF	V _{GS} =0V, V _{DS} =25V, f=1MHz
Coss	-	71	-		
Crss	-	32	-		
Source-Drain Diode					
I _S *1	-	-	18	A	
I _{SM} *3	-	-	40		
V _{SD} *1	-	0.87	1.3	V	I _F =I _S , V _{GS} =0V
trr	-	50	-	ns	I _F =18A, dI _F /dt=100A/μs
Q _{rr}	-	80	-	nC	

Note : *1.Pulse Test : Pulse Width ≤300μs, Duty Cycle≤2%
 *2.Independent of operating temperature
 *3.Pulse width limited by maximum junction temperature.

Recommended soldering footprint

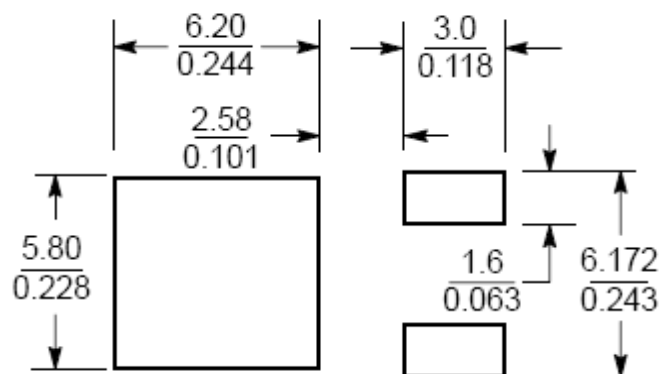

Unit ($\frac{\text{mm}}{\text{inch}}$)

Typical Characteristics

Typical Output Characteristics

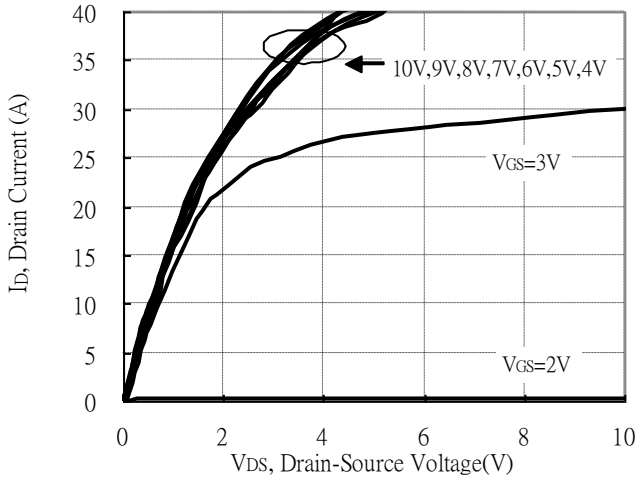

Brekdown Voltage vs Ambient Temperature

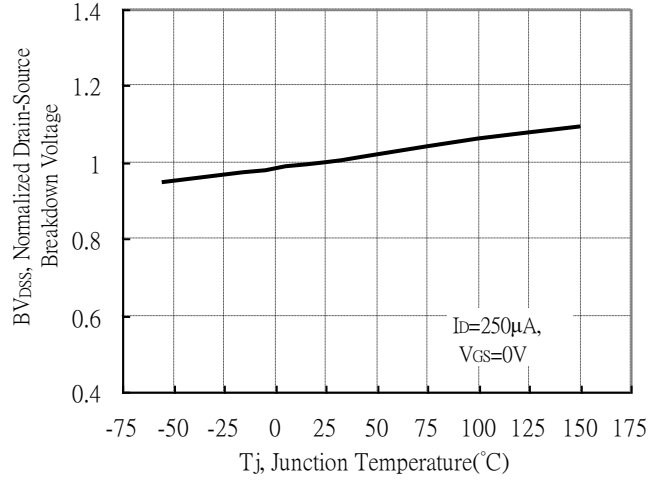

Static Drain-Source On-State resistance vs Drain Current

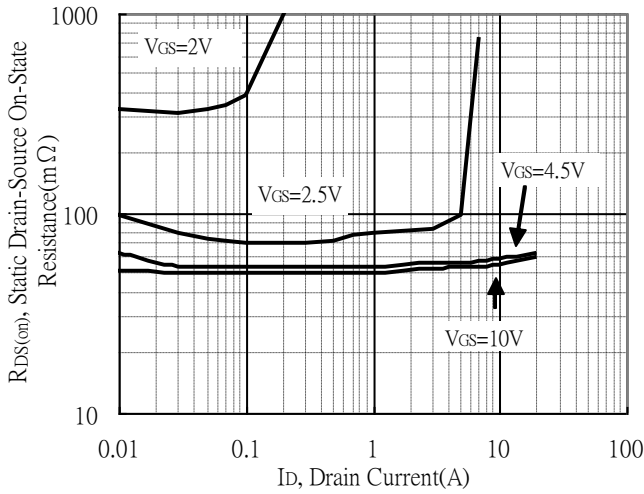

Reverse Drain Current vs Source-Drain Voltage

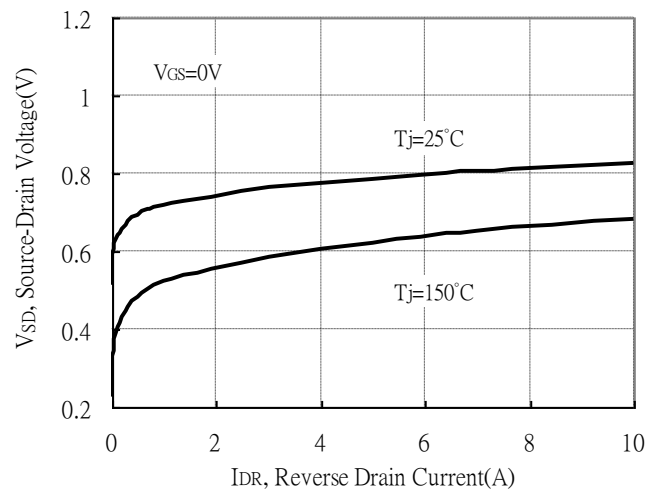

Static Drain-Source On-State Resistance vs Gate-Source Voltage

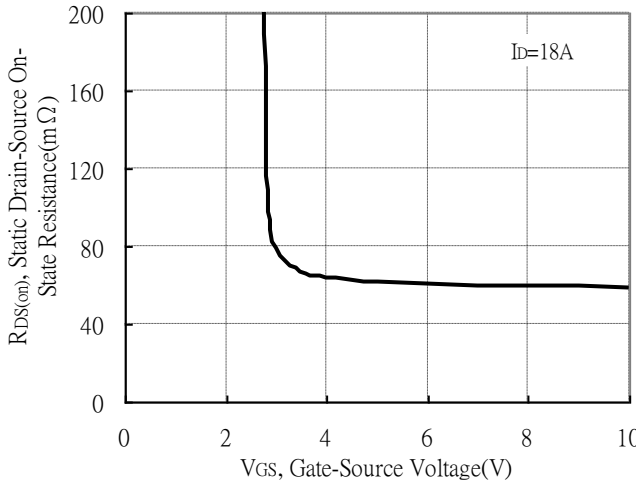

Drain-Source On-State Resistance vs Junction Temperature

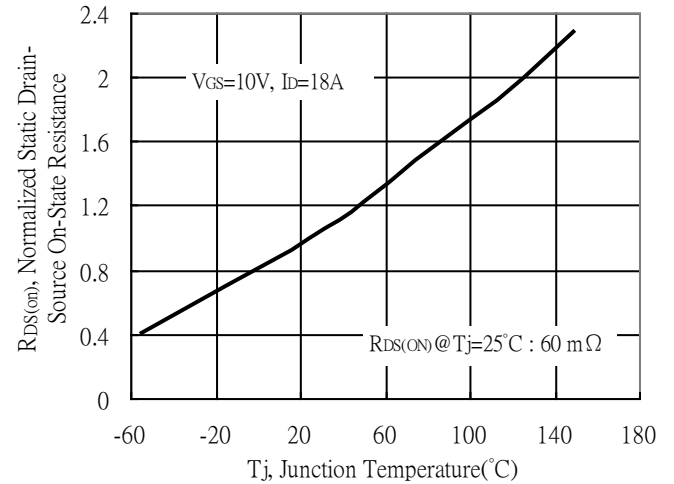

Typical Characteristics(Cont.)

Capacitance vs Drain-to-Source Voltage

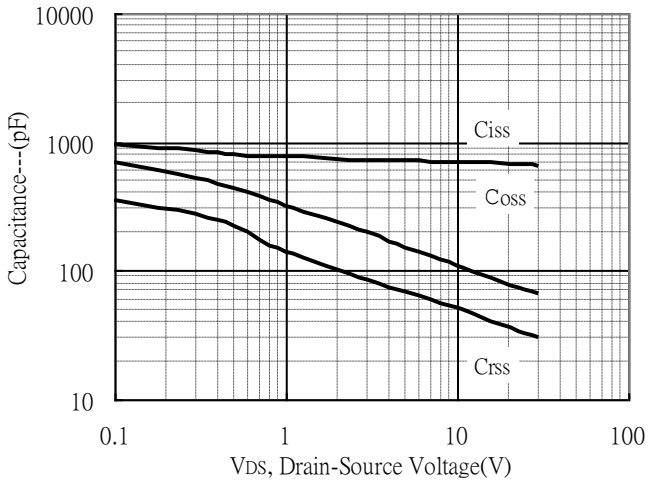

Threshold Voltage vs Junction Temperature

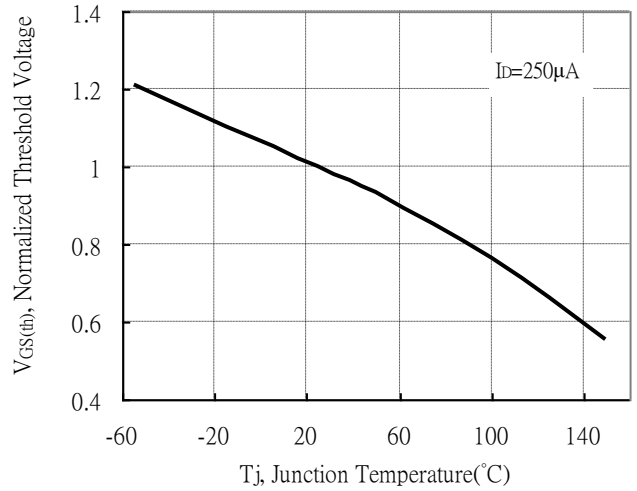

Forward Transfer Admittance vs Drain Current

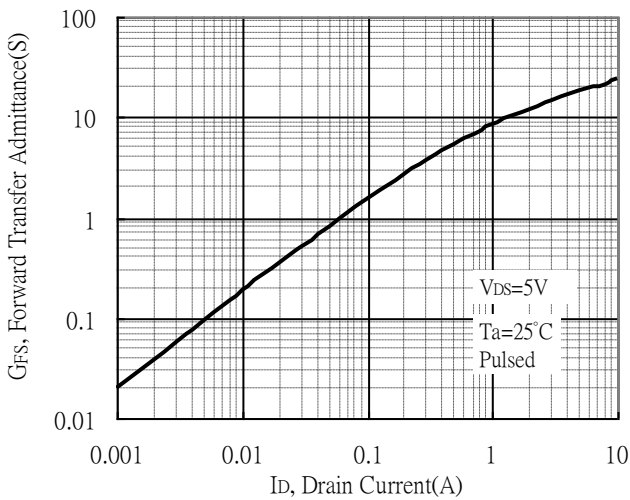

Gate Charge Characteristics

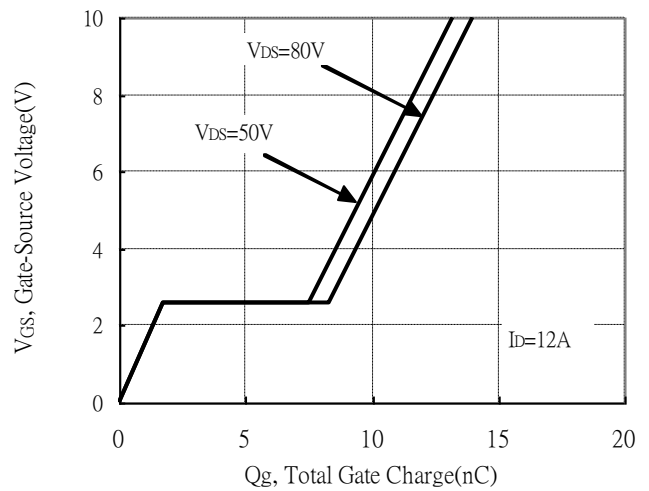

Maximum Safe Operating Area

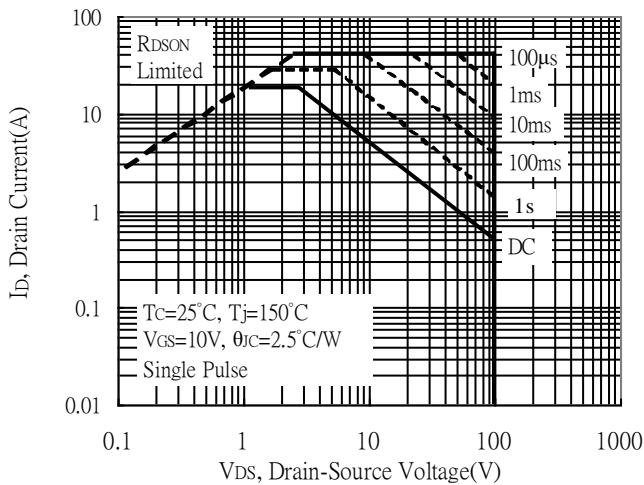

Maximum Drain Current vs Case Temperature

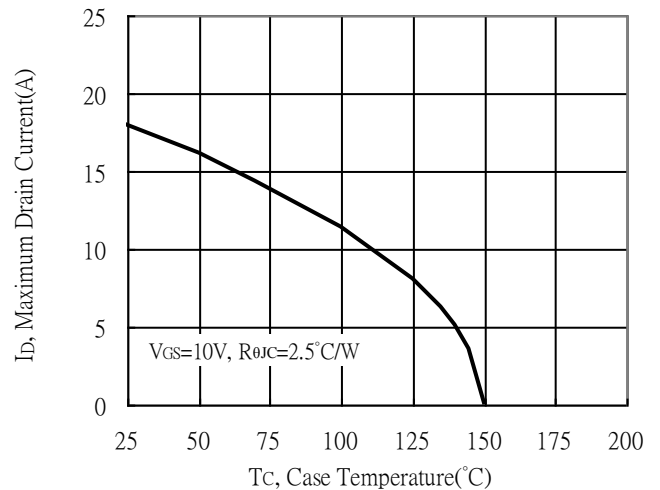

Typical Characteristics(Cont.)

Typical Transfer Characteristics

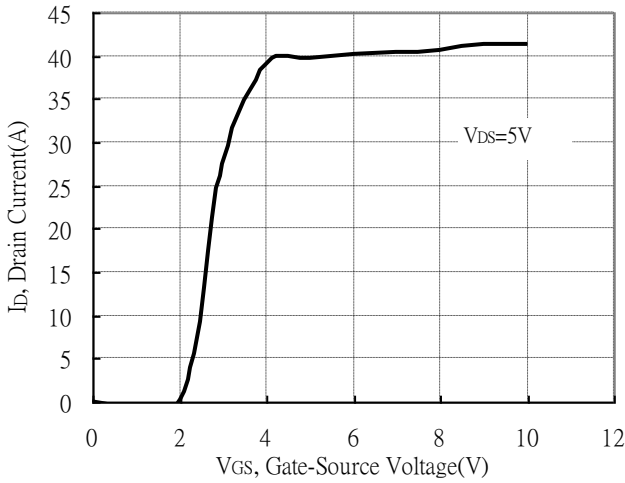

Power Derating Curve

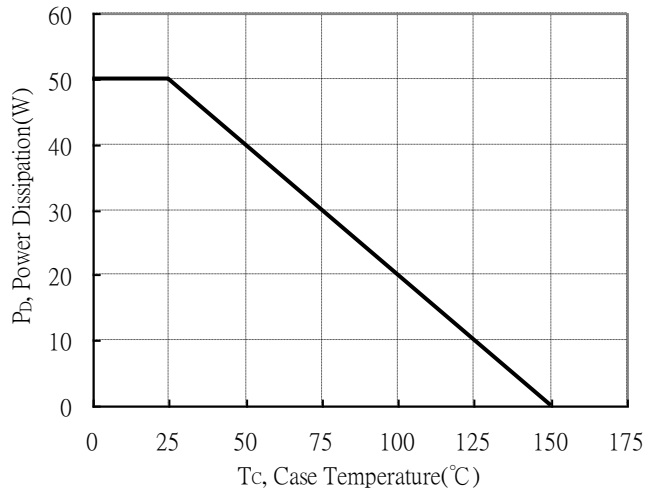

Transient Thermal Response Curves

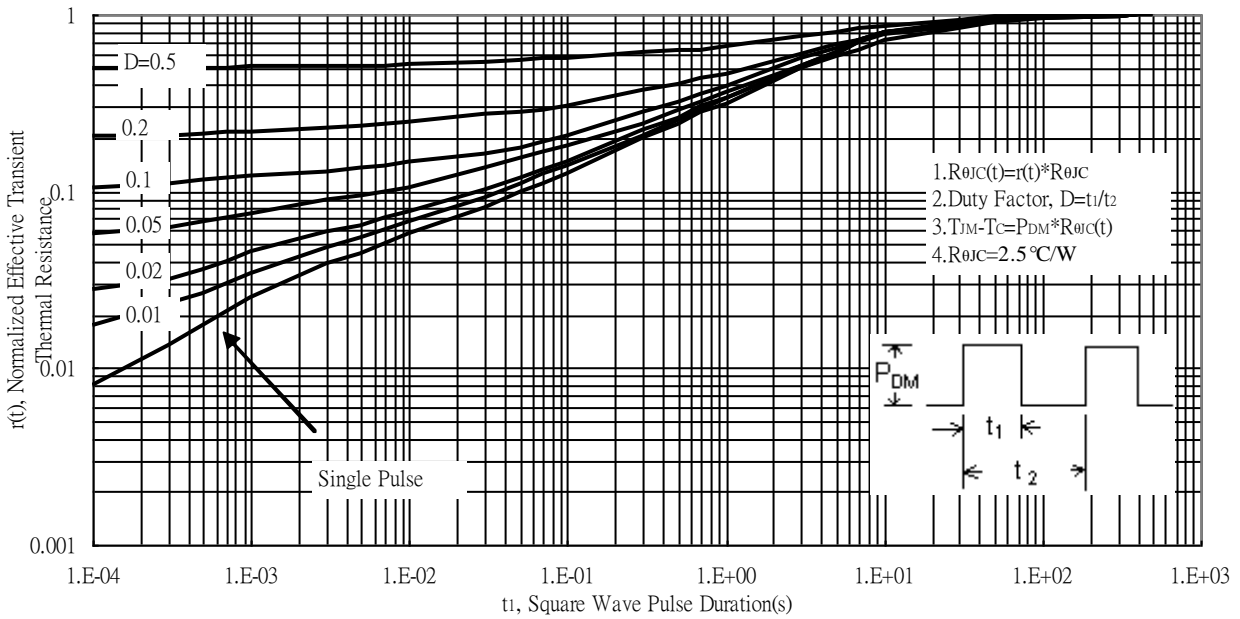

Reel Dimension

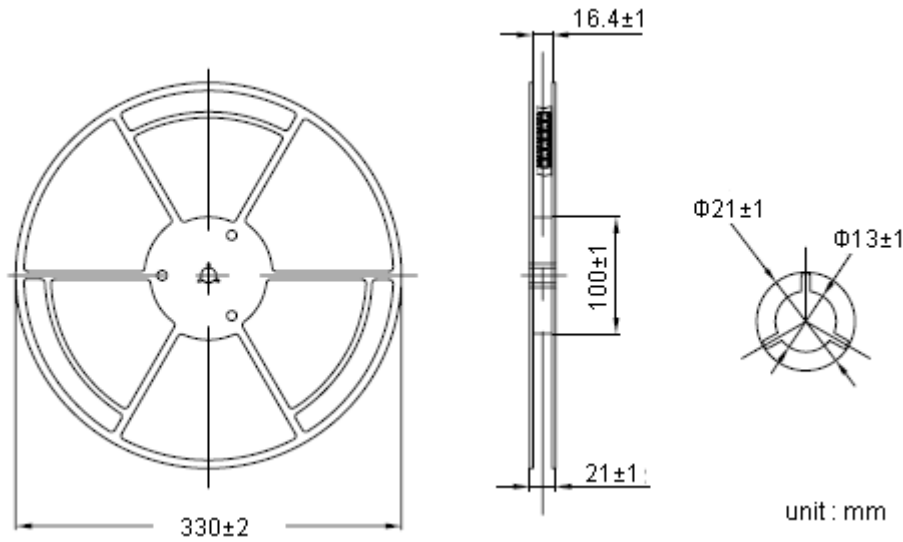

Carrier Tape Dimension

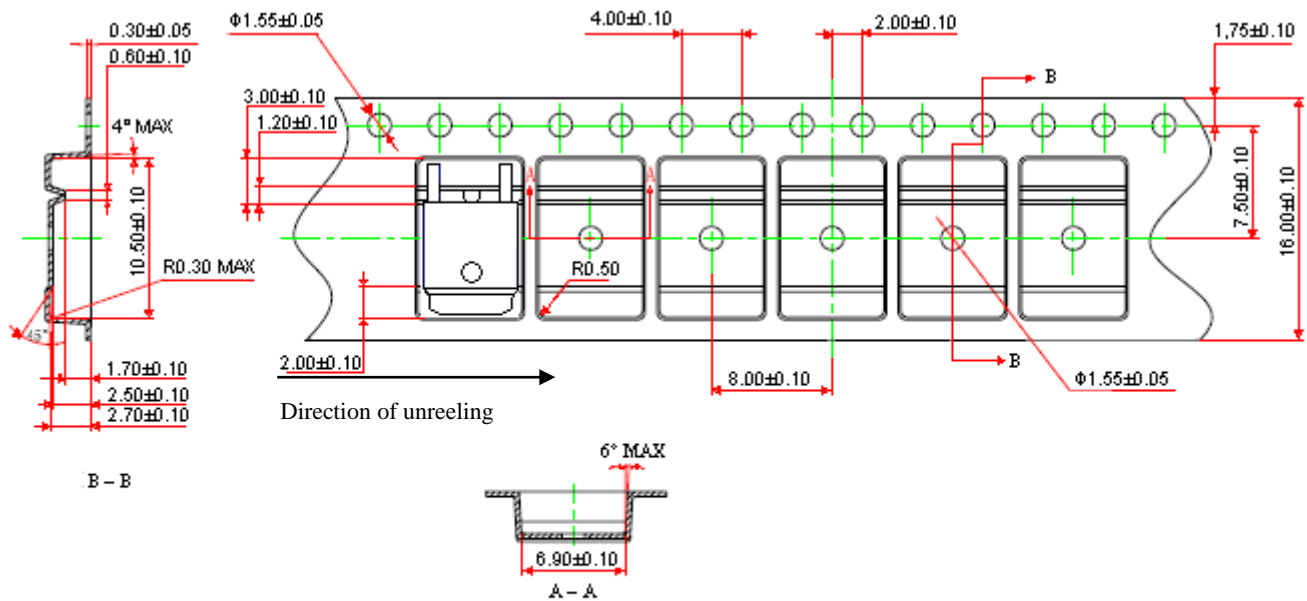

Notes:

1. 10 sprocket hole pitch cumulative tolerance ± 0.2 .
2. Camber not to exceed 1mm in 100mm.

3. Material: conductive black polystyrene, antistatic coated : $10^5 \Omega/\square \sim 10^{11} \Omega/\square$

unit : mm

TO-252 Dimension

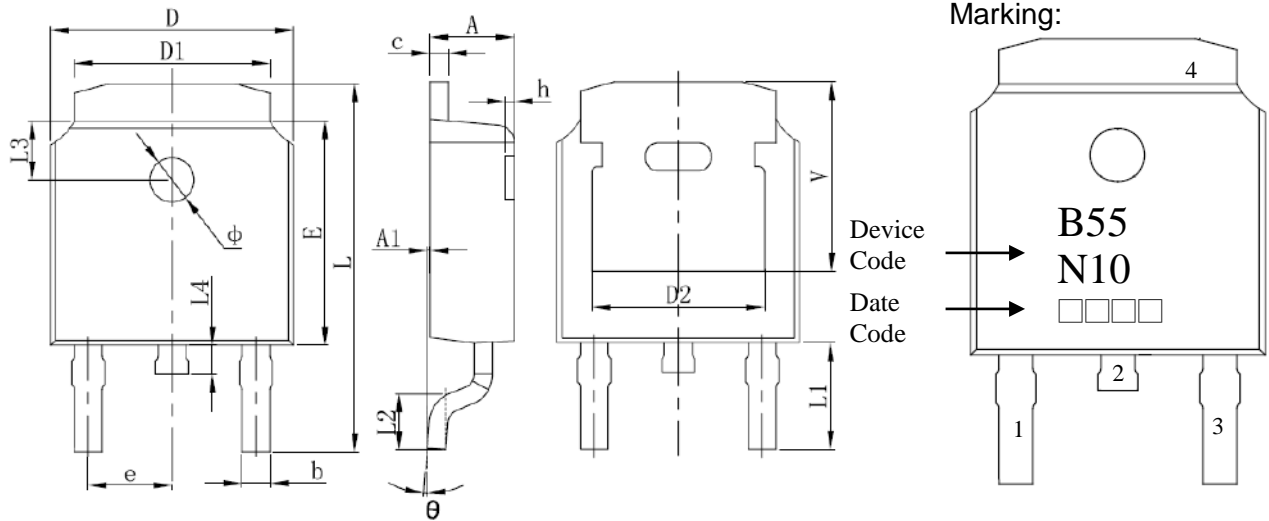

3-Lead TO-252 Plastic Surface Mount Package

Style: Pin 1.Gate 2.Drain 3.Source
 4.Drain

Date Code :

First Code : Last digit of Christian Year

Second Code : Month Code : Jan→A, Feb→B, Mar→C, Apr→D, May→E, Jun→F, Jul→G,

Aug→H, Sep→J, Oct→K, Nov→L, Dec→M

Last Two Codes : Production Serial Code, 01~99

DIM	Inches		Millimeters		DIM	Inches		Millimeters	
	Min.	Max.	Min.	Max.		Min.	Max.	Min.	Max.
A	0.087	0.094	2.200	2.400	L	0.382	0.406	9.712	10.312
A1	0.000	0.005	0.000	0.127	L1	0.114	REF	2.900	REF
b	0.025	0.030	0.635	0.770	L2	0.055	0.067	1.400	1.700
c	0.018	0.023	0.460	0.580	L3	0.063	REF	1.600	REF
D	0.256	0.264	6.500	6.700	L4	0.024	0.039	0.600	1.000
D1	0.201	0.215	5.100	5.460	Φ	0.043	0.051	1.100	1.300
D2	0.190	REF	4.830	REF	θ	0°	8°	0°	8°
E	0.236	0.244	6.000	6.200	h	0.000	0.012	0.000	0.300
e	0.086	0.094	2.186	2.386	v	0.207	REF	5.250	REF