

## N-Channel Enhancement Mode MOSFET

### Features:

- Low On Resistance
- Low Gate Charge
- Fast Switching Characteristic
- ESD protected gate

TO-252

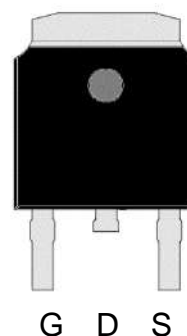

$BV_{DSS}$	100V
$I_D @ V_{GS}=10V, T_C=25^\circ C$	7A
$I_D @ V_{GS}=10V, T_A=25^\circ C$	2.9A
$R_{DS(ON)}$ typ. @ $V_{GS}=10V, I_D=2.5A$	105m $\Omega$
$R_{DS(ON)}$ typ. @ $V_{GS}=4.5V, I_D=1.5A$	160m $\Omega$

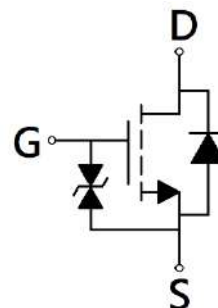

G : Gate S : Source D : Drain

### Ordering Information

Device	Package	Shipping
KJB100N10RKE	TO-252 (Pb-free lead plating and halogen-free package)	2500 pcs / Tape & Reel

### Absolute Maximum Ratings (T<sub>A</sub>=25°C)

Parameter	Symbol	Limits	Unit
Drain-Source Voltage	V <sub>DS</sub>	100	V
Gate-Source Voltage	V <sub>GS</sub>	±20	
Continuous Drain Current @ V <sub>GS</sub> =10V, T <sub>C</sub> =25°C	I <sub>D</sub>	7	A
Continuous Drain Current @ V <sub>GS</sub> =10V, T <sub>C</sub> =100°C		4.4	
Continuous Drain Current @ V <sub>GS</sub> =10V, T <sub>A</sub> =25°C		2.9	
Continuous Drain Current @ V <sub>GS</sub> =10V, T <sub>A</sub> =70°C		2.3	
Pulsed Drain Current	I <sub>DM</sub>	28	
Continuous Body Diode Forward Current @ T <sub>C</sub> =25°C	I <sub>S</sub>	7	mJ
Avalanche Current @ L=0.1mH	I <sub>AS</sub>	6	
Avalanche Energy @ L=0.5mH	E <sub>AS</sub>	6.3	W
Total Power Dissipation	T <sub>C</sub> =25°C	14.7	
	T <sub>C</sub> =100°C	5.9	
	T <sub>A</sub> =25°C	2.5	
	T <sub>A</sub> =70°C	1.6	
Operating Junction and Storage Temperature Range	T <sub>J</sub> , T <sub>stg</sub>	-55~+150	°C

### Thermal Data

Parameter	Symbol	Steady State	Unit
Thermal Resistance, Junction-to-case	R <sub>θJC</sub>	8.5	°C/W
Thermal Resistance, Junction-to-ambient	R <sub>θJA</sub>	50	

Note:

- \*a. The power dissipation P<sub>D</sub> is based on T<sub>J(MAX)</sub>=150°C, using junction-to-case thermal resistance, and is more useful in setting the upper dissipation limit for cases where additional heatsinking is used.
- \*b. The value of R<sub>θJA</sub> is measured with the device mounted on 1 in<sup>2</sup>FR -4 board with 2 oz. copper, in a still air environment with T<sub>A</sub>=25°C. The power dissipation P<sub>D</sub> is based on R<sub>θJA</sub> and the maximum allowed junction temperature of 150°C. The value in any given application depends on the user's specific board design.
- \*c. Repetitive rating, pulse width limited by junction temperature T<sub>J(MAX)</sub>=150°C. Ratings are based on low frequency and low duty cycles to keep initial T<sub>J</sub>=25°C.

**Electrical Characteristics (T<sub>A</sub>=25°C, unless otherwise specified)**

Symbol	Min.	Typ.	Max.	Unit	Test Conditions
<b>Static</b>					
BV <sub>DSS</sub>	100	-	-	V	V <sub>GS</sub> =0V, I <sub>D</sub> =250μA
V <sub>GS(th)</sub>	1	-	2.5		V <sub>DS</sub> =V <sub>GS</sub> , I <sub>D</sub> =250μA
G <sub>FS</sub>	-	3.2	-	S	V <sub>DS</sub> =10V, I <sub>D</sub> =1A
I <sub>GSS</sub>	-	-	±10	μA	V <sub>GS</sub> =±16V, V <sub>DS</sub> =0V
I <sub>DSS</sub>	-	-	1		V <sub>DS</sub> =80V, V <sub>GS</sub> =0V
R <sub>DS(ON)</sub>	-	105	135	mΩ	V <sub>GS</sub> =10V, I <sub>D</sub> =2.5A
	-	160	220		V <sub>GS</sub> =4.5V, I <sub>D</sub> =1.5A
<b>Dynamic</b>					
C <sub>iss</sub>	-	250	-	pF	V <sub>DS</sub> =50V, V <sub>GS</sub> =0V, f=1MHz
C <sub>oss</sub>	-	32	-		
C <sub>rss</sub>	-	16	-		
R <sub>g</sub>	-	5.4	-	Ω	f=1MHz
Q <sub>g</sub> *1, 2	-	4.2	-	nC	V <sub>DS</sub> =50V, I <sub>D</sub> =2A, V <sub>GS</sub> =10V
Q <sub>gs</sub> *1, 2	-	0.7	-		
Q <sub>gd</sub> *1, 2	-	0.6	-		
t <sub>d(ON)</sub> *1, 2	-	4.2	-	ns	V <sub>DS</sub> =50V, I <sub>D</sub> =2A, V <sub>GS</sub> =10V, R <sub>GS</sub> =1Ω
t <sub>r</sub> *1, 2	-	14	-		
t <sub>d(OFF)</sub> *1, 2	-	12	-		
t <sub>f</sub> *1, 2	-	5	-		
<b>Source-Drain Diode</b>					
V <sub>SD</sub> *1	-	0.84	1.2	V	I <sub>S</sub> =2A, V <sub>GS</sub> =0V
t <sub>rr</sub>	-	22	-	ns	I <sub>F</sub> =2A, dI <sub>F</sub> /dt=100A/μs
Q <sub>rr</sub>	-	21	-	nC	

Note:

\*1. Pulse Test : Pulse Width ≤300μs, Duty Cycle≤2%

\*2. Independent of operating temperature

## Typical Characteristics

Typical Output Characteristics

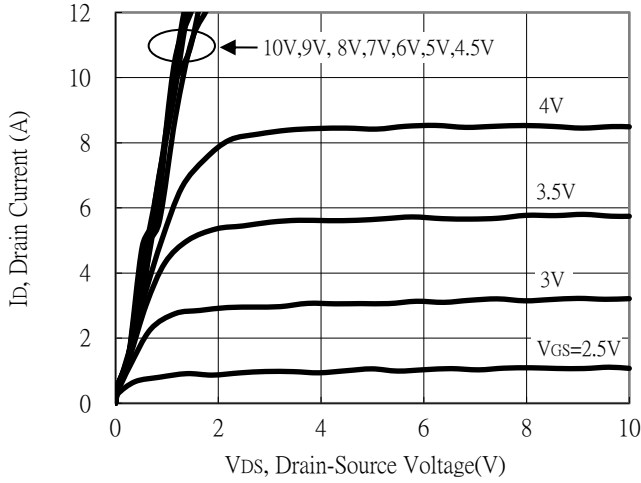

Breakdown Voltage vs Ambient Temperature

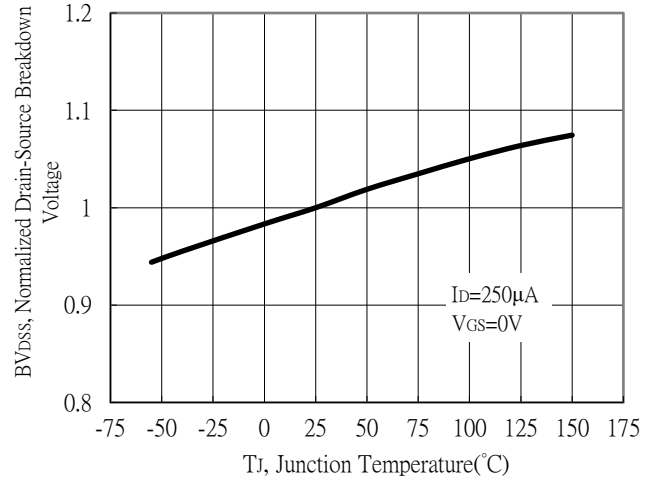

Static Drain-Source On-State resistance vs Drain Current

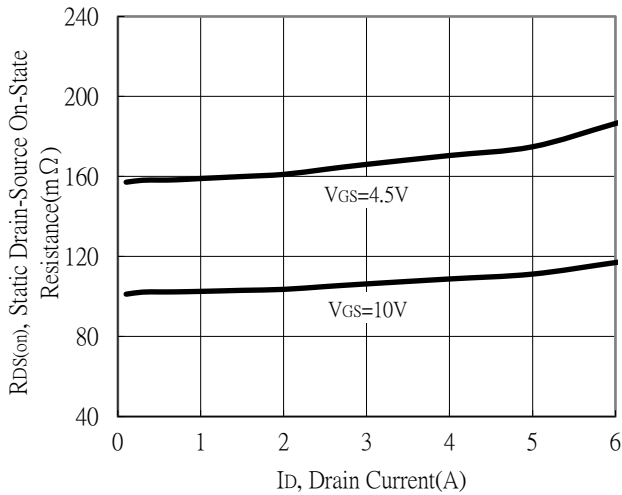

Body Diode Current vs Source-Drain Voltage

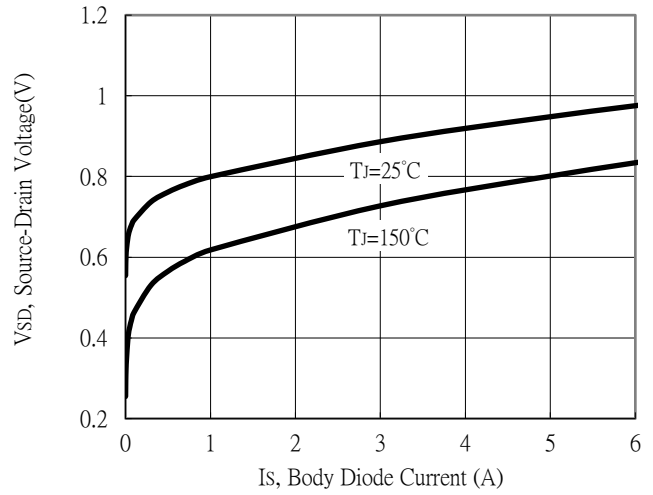

Static Drain-Source On-State Resistance vs Gate-Source Voltage

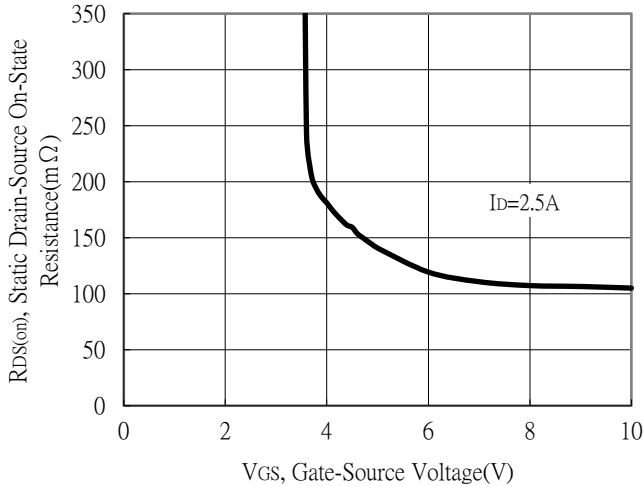

Drain-Source On-State Resistance vs Junction Temperature

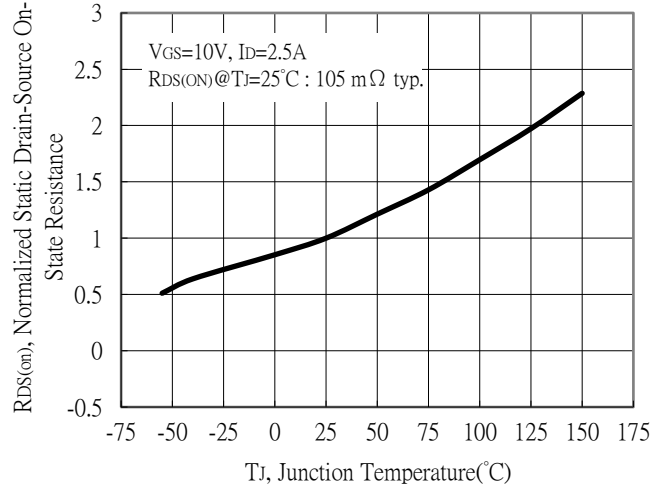

**Typical Characteristics (Cont.)**

Capacitance vs Drain-to-Source Voltage

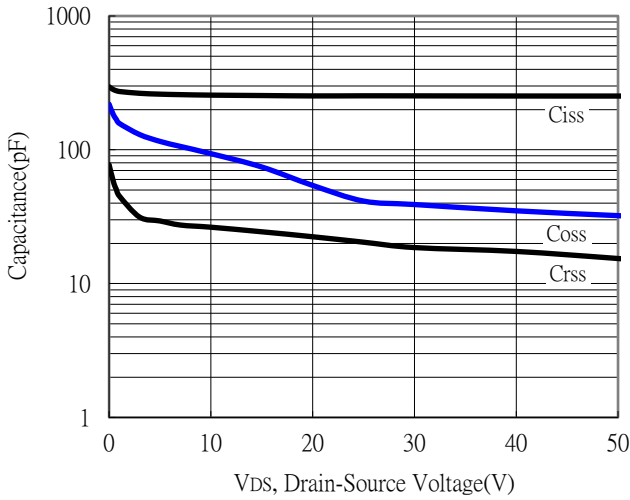

Threshold Voltage vs Junction Temperature

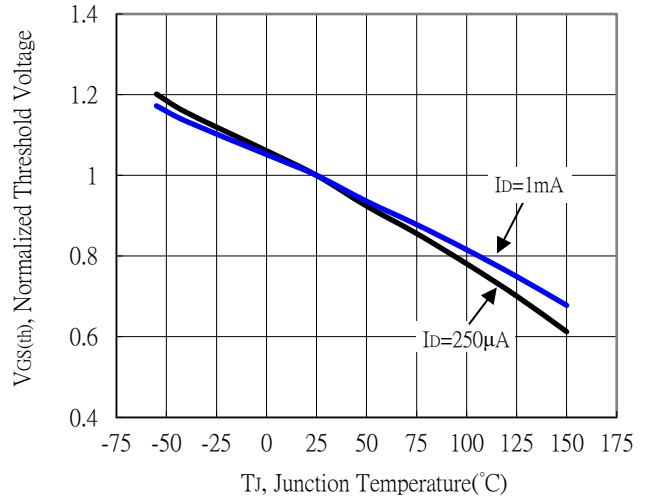

Forward Transfer Admittance vs Drain Current

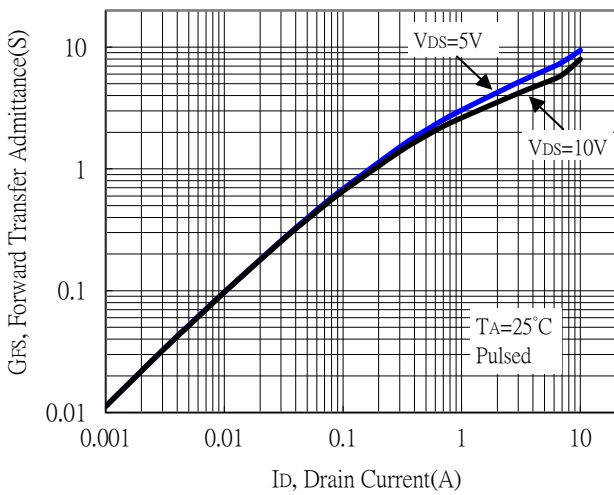

Gate Charge Characteristics

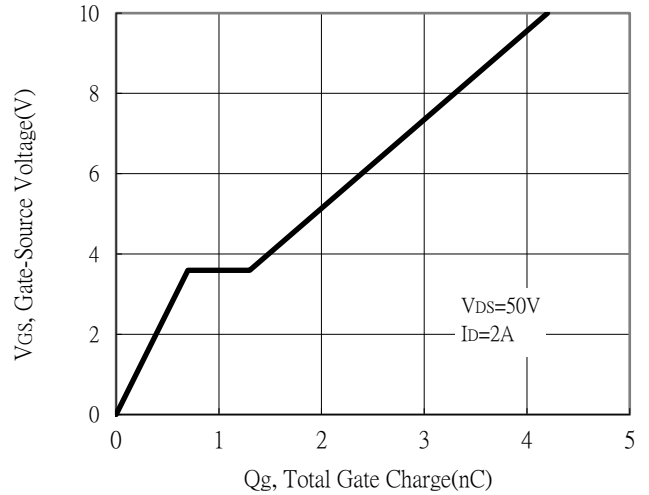

Maximum Safe Operating Area

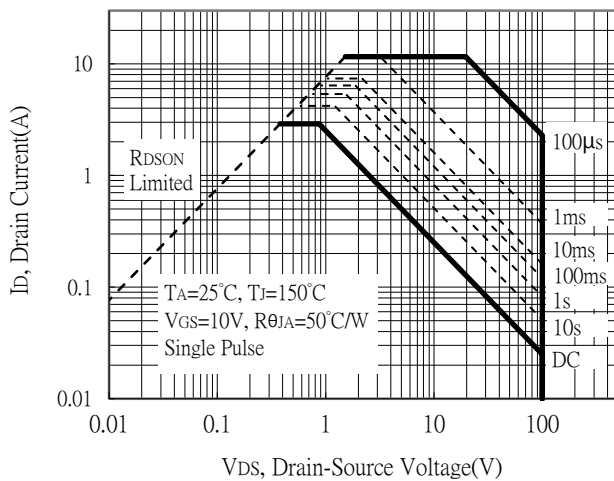

Maximum Drain Current vs Junction Temperature

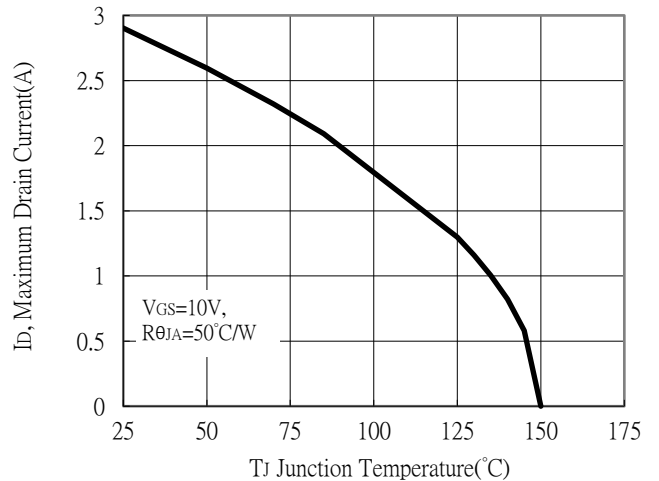

**Typical Characteristics (Cont.)**

Single Pulse Power Rating, Junction to Ambient

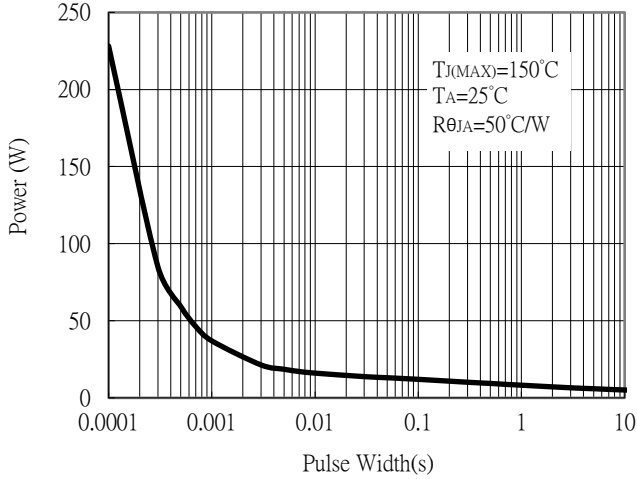

Transient Thermal Response Curves

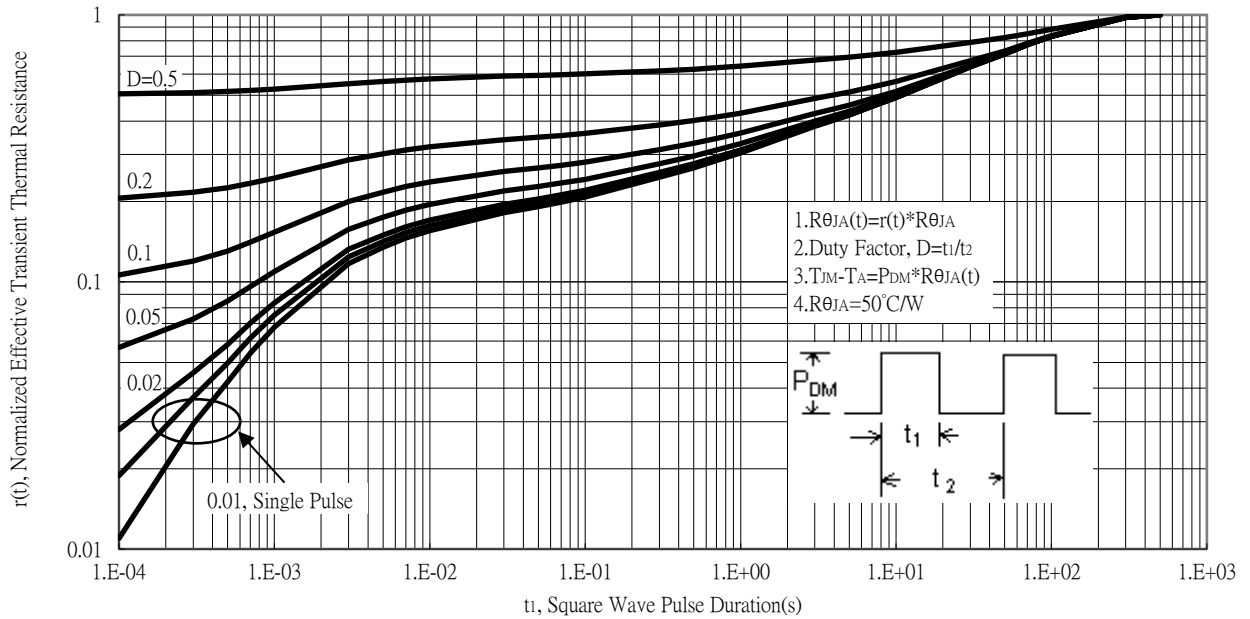

**Recommended soldering footprint**

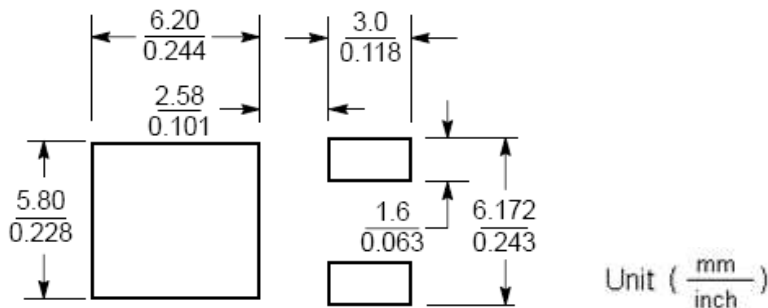

### Reel Dimension

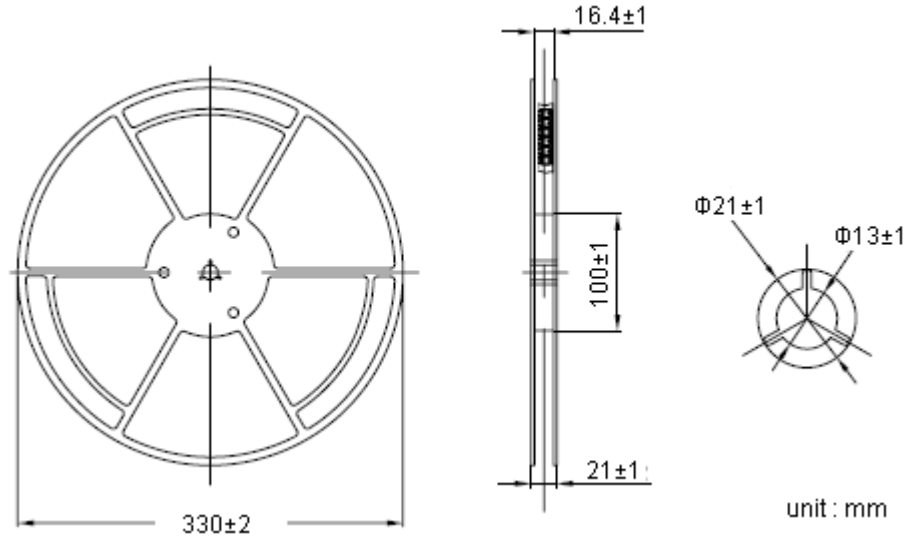

### Carrier Tape Dimension

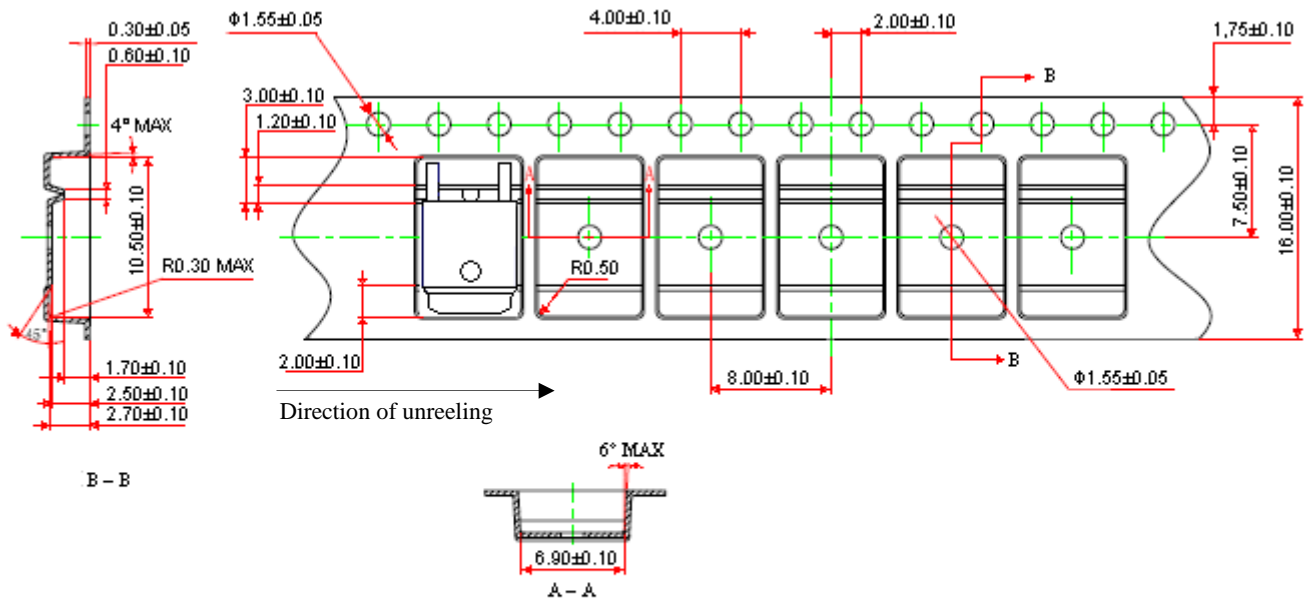

Notes:

1. 10 sprocket hole pitch cumulative tolerance  $\pm 0.2$ .
2. Camber not to exceed 1mm in 100mm.
3. Material: conductive black polystyrene, antistatic coated :  $10^5 \Omega/\square \sim 10^{11} \Omega/\square$

unit : mm

**TO-252 Dimension (C forming)**

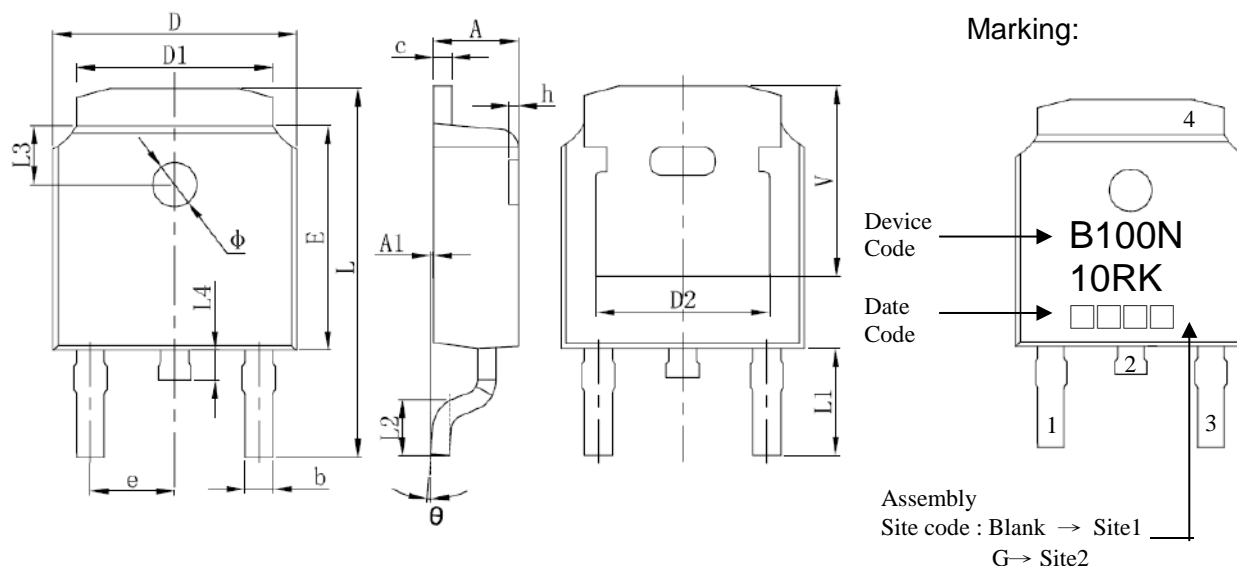

3-Lead TO-252 Plastic Surface Mount Package

Style: Pin 1.Gate 2.Drain 3.Source  
 4.Drain

Date Code(counting from left to right) :  
 1<sup>st</sup> code: year code, the last digit of Christian year  
 2<sup>nd</sup> code : month code, Jan→A, Feb→B, Mar→C, Apr→D  
 May→E, Jun→F, Jul→G, Aug→H, Sep→J,  
 Oct→K, Nov→L, Dec→M  
 3<sup>rd</sup> and 4<sup>th</sup> codes : production serial number, 01~99

DIM	Inches		Millimeters		DIM	Inches		Millimeters	
	Min.	Max.	Min.	Max.		Min.	Max.	Min.	Max.
A	0.087	0.094	2.200	2.400	L	0.382	0.406	9.712	10.312
A1	0.000	0.005	0.000	0.127	L1	0.114	REF	2.900	REF
b	0.025	0.030	0.635	0.770	L2	0.055	0.067	1.400	1.700
c	0.018	0.023	0.460	0.580	L3	0.063	REF	1.600	REF
D	0.256	0.264	6.500	6.700	L4	0.024	0.039	0.600	1.000
D1	0.201	0.215	5.100	5.460	Φ	0.043	0.051	1.100	1.300
D2	0.190	REF	4.830	REF	θ	0°	8°	0°	8°
E	0.236	0.244	6.000	6.200	h	0.000	0.012	0.000	0.300
e	0.086	0.094	2.186	2.386	V	0.207	REF	5.250	REF



**TO-252 Dimension (G forming)**

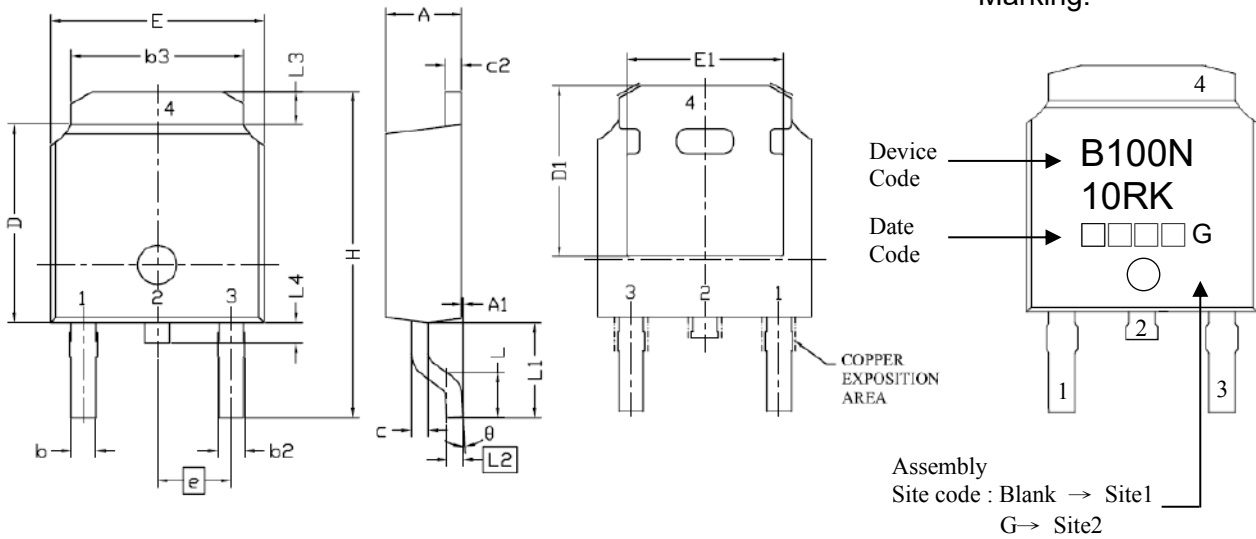

3-Lead TO-252 Plastic Surface Mount Package

Style: Pin 1.Gate 2.Drain 3.Source  
 4.Drain

Date Code(counting from left to right) :  
 1<sup>st</sup> code: year code, the last digit of Christian year  
 2<sup>nd</sup> code : month code, Jan→A, Feb→B, Mar→C, Apr→D  
 May→E, Jun→F, Jul→G, Aug→H, Sep→J,  
 Oct→K, Nov→L, Dec→M  
 3<sup>rd</sup> and 4<sup>th</sup> codes : production serial number, 01~99

DIM	Inches		Millimeters		DIM	Inches		Millimeters	
	Min.	Max.	Min.	Max.		Min.	Max.	Min.	Max.
E	0.251	0.265	6.400	6.731	b3	0.205	0.215	5.210	5.460
L	0.055	0.070	1.400	1.770	e	0.090 BSC		2.286 BSC	
L1	0.107 REF		2.743 REF		A	0.087	0.093	2.200	2.380
L2	0.020 BSC		0.508 BSC		A1	0.000	0.005	0.000	0.127
L3	0.035	0.050	0.890	1.270	c	0.018	0.024	0.460	0.600
L4	0.025	0.039	0.640	1.010	c2	0.018	0.022	0.460	0.580
D	0.236	0.245	6.000	6.223	D1	0.205	-	5.210	-
H	0.370	0.409	9.400	10.400	E1	0.173	-	4.400	-
b	0.025	0.034	0.640	0.880	θ	0°	10°	0°	10°
b2	0.030	0.044	0.770	1.140					