

## N-Channel Enhancement Mode Power MOSFET

### Features:

- Low On Resistance
- Low Gate Charge
- Fast Switching Characteristic
- ESD protected gate

TO-252

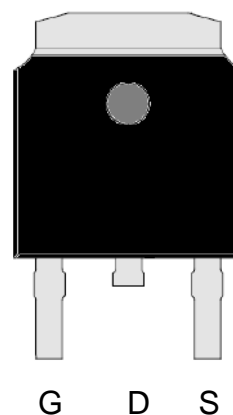

$BV_{DSS}$	60V
$I_D @ V_{GS}=10V, T_C=25^\circ C$	36A
$I_D @ V_{GS}=10V, T_A=25^\circ C$	8A
$R_{DS(ON) typ. @ V_{GS}=10V, I_D=8A}$	13.4m $\Omega$
$R_{DS(ON) typ. @ V_{GS}=4.5V, I_D=8A}$	23m $\Omega$

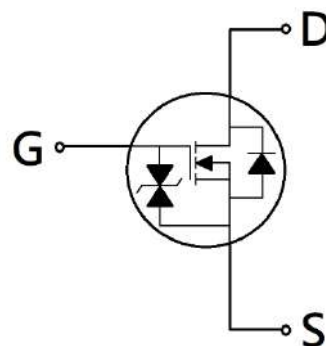

G : Gate S : Source D : Drain

### Ordering Information

Device	Package	Shipping
KJB020N06K	TO-252 (Pb-free lead plating and halogen-free package)	2500 pcs / Tape & Reel

### Absolute Maximum Ratings (T<sub>A</sub>=25°C)

Parameter	Symbol	Limits	Unit
Drain-Source Voltage	V <sub>DS</sub>	60	V
Gate-Source Voltage	V <sub>GS</sub>	±20	
Continuous Drain Current @ V <sub>GS</sub> =10V, T <sub>C</sub> =25°C	I <sub>D</sub>	36	A
Continuous Drain Current @ V <sub>GS</sub> =10V, T <sub>C</sub> =100°C		22.8	
Continuous Drain Current @ V <sub>GS</sub> =10V, T <sub>A</sub> =25°C		8	
Continuous Drain Current @ V <sub>GS</sub> =10V, T <sub>A</sub> =70°C		6.5	
Pulsed Drain Current	I <sub>DM</sub>	144	
Continuous Body Diode Forward Current @ T <sub>C</sub> =25°C	I <sub>S</sub>	36	mJ
Avalanche Current @ L=0.1mH	I <sub>AS</sub>	20	
Avalanche Energy @ L=0.5mH	E <sub>AS</sub>	30	W
Total Power Dissipation	T <sub>C</sub> =25°C	50	
	T <sub>C</sub> =100°C	20	
	T <sub>A</sub> =25°C	2.5	
	T <sub>A</sub> =70°C	1.6	
Operating Junction and Storage Temperature Range	T <sub>J</sub> , T <sub>stg</sub>	-55~+150	°C

### Thermal Data

Parameter	Symbol	Steady State	Unit
Thermal Resistance, Junction-to-case	R <sub>θJC</sub>	2.5	°C/W
Thermal Resistance, Junction-to-ambient	R <sub>θJA</sub>	50	

Note:

- \*a. The power dissipation P<sub>D</sub> is based on T<sub>J(MAX)</sub>=150°C, using junction-to-case thermal resistance, and is more useful in setting the upper dissipation limit for cases where additional heatsinking is used.
- \*b. The value of R<sub>θJA</sub> is measured with the device mounted on 1 in<sup>2</sup>FR -4 board with 2 oz. copper, in a still air environment with T<sub>A</sub>=25°C. The power dissipation P<sub>D</sub> is based on R<sub>θJA</sub> and the maximum allowed junction temperature of 150°C. The value in any given application depends on the user's specific board design.
- \*c. Repetitive rating, pulse width limited by junction temperature T<sub>J(MAX)</sub>=150°C. Ratings are based on low frequency and low duty cycles to keep initial T<sub>J</sub>=25°C.

**Electrical Characteristics (T<sub>A</sub>=25°C, unless otherwise specified)**

Symbol	Min.	Typ.	Max.	Unit	Test Conditions
<b>Static</b>					
BV <sub>DSS</sub>	60	-	-	V	V <sub>GS</sub> =0V, I <sub>D</sub> =250μA
V <sub>GS(th)</sub>	1	-	2.5		V <sub>DS</sub> =V <sub>GS</sub> , I <sub>D</sub> =250μA
G <sub>FS</sub>	-	16.3	-	S	V <sub>DS</sub> =5V, I <sub>D</sub> =7A
I <sub>GSS</sub>	-	-	±10	μA	V <sub>GS</sub> =±16V, V <sub>DS</sub> =0V
I <sub>DSS</sub>	-	-	1		V <sub>DS</sub> =48V, V <sub>GS</sub> =0V
R <sub>DS(ON)</sub>	-	13.4	20	mΩ	V <sub>GS</sub> =10V, I <sub>D</sub> =8A
	-	23	45		V <sub>GS</sub> =4.5V, I <sub>D</sub> =8A
<b>Dynamic</b>					
C <sub>iss</sub>	-	720	-	pF	V <sub>DS</sub> =30V, V <sub>GS</sub> =0V, f=1MHz
C <sub>oss</sub>	-	115	-		
C <sub>rss</sub>	-	60	-		
R <sub>g</sub>	-	2.7	-	Ω	f=1MHz
Q <sub>g</sub> *1, 2	-	19	-	nC	V <sub>DS</sub> =30V, I <sub>D</sub> =8A, V <sub>GS</sub> =10V
Q <sub>gs</sub> *1, 2	-	1.6	-		
Q <sub>gd</sub> *1, 2	-	8.4	-		
t <sub>d(ON)</sub> *1, 2	-	8.6	-	ns	V <sub>DS</sub> =30V, I <sub>D</sub> =8A, V <sub>GS</sub> =10V, R <sub>GS</sub> =6Ω
t <sub>r</sub> *1, 2	-	18	-		
t <sub>d(OFF)</sub> *1, 2	-	40	-		
t <sub>f</sub> *1, 2	-	20	-		
<b>Source-Drain Diode</b>					
V <sub>SD</sub> *1	-	0.96	1.2	V	I <sub>S</sub> =20A, V <sub>GS</sub> =0V
t <sub>rr</sub>	-	14	-	ns	I <sub>F</sub> =20A, dI <sub>F</sub> /dt=100A/μs
Q <sub>rr</sub>	-	85	-	nC	

Note:

\*1. Pulse Test : Pulse Width ≤300μs, Duty Cycle≤2%

\*2. Independent of operating temperature

## Typical Characteristics

Typical Output Characteristics

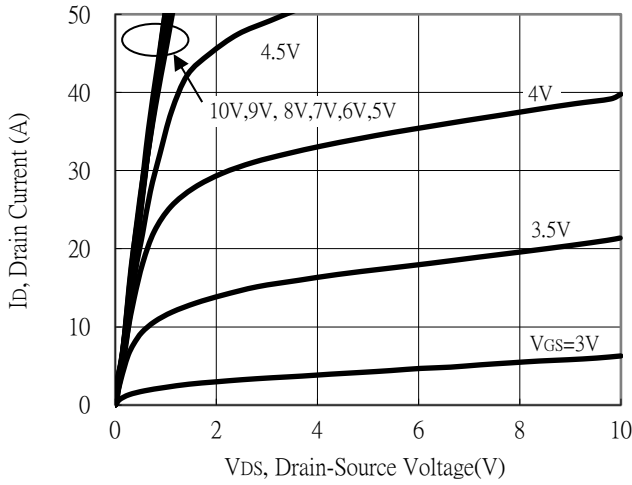

Breakdown Voltage vs Ambient Temperature

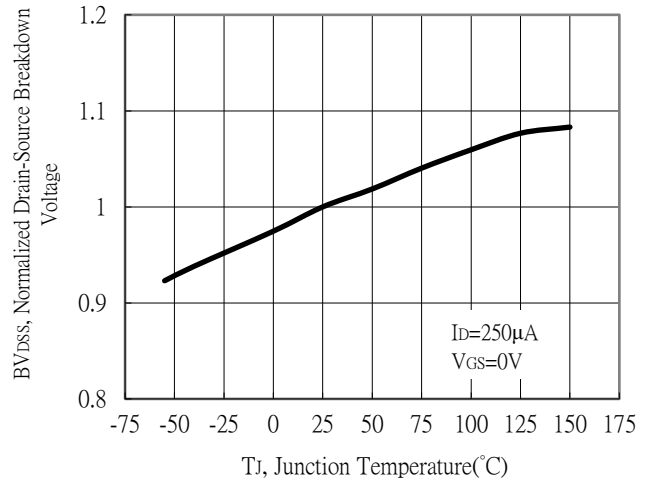

Static Drain-Source On-State resistance vs Drain Current

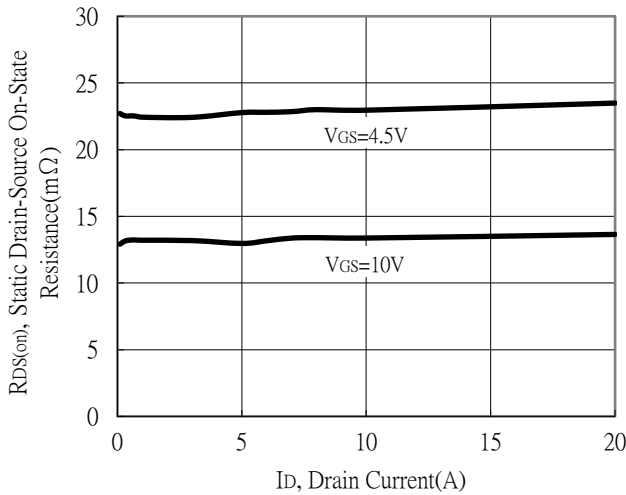

Body Diode Current vs Source-Drain Voltage

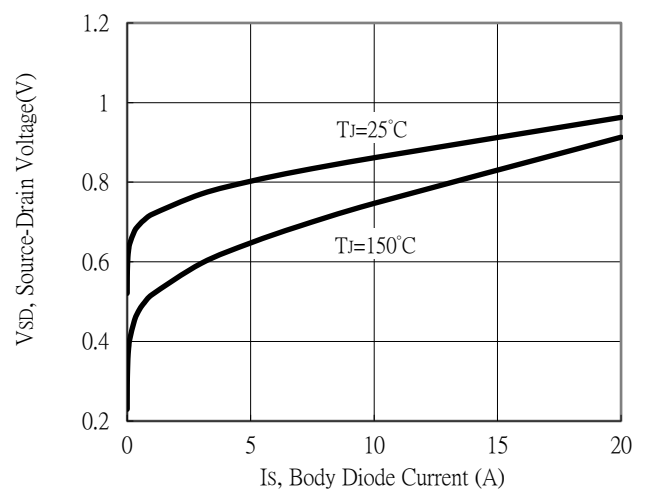

Static Drain-Source On-State Resistance vs Gate-Source Voltage

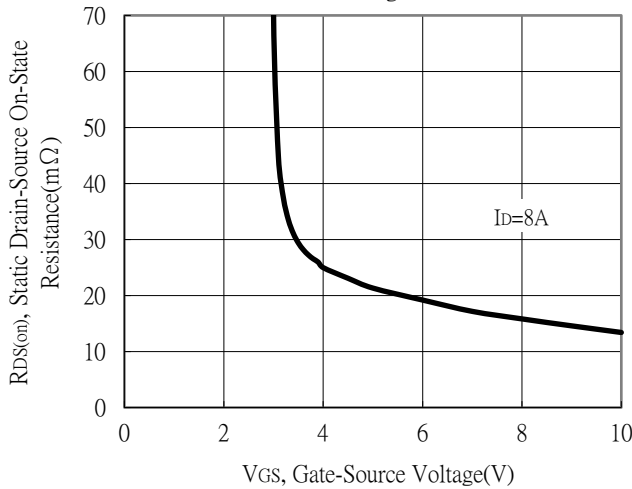

Drain-Source On-State Resistance vs Junction Temperature

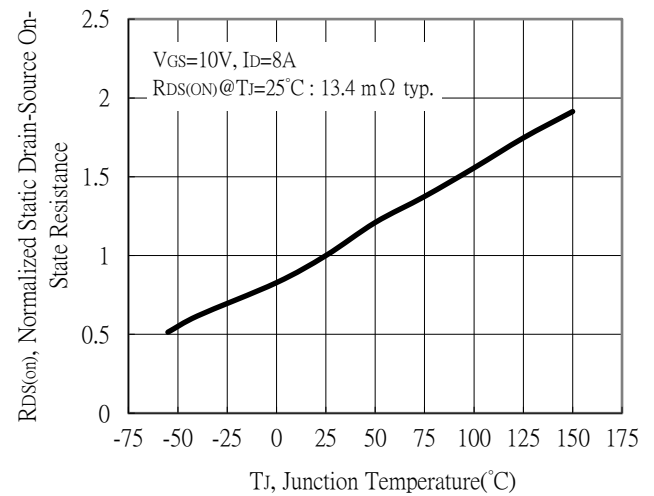

**Typical Characteristics (Cont.)**

Capacitance vs Drain-to-Source Voltage

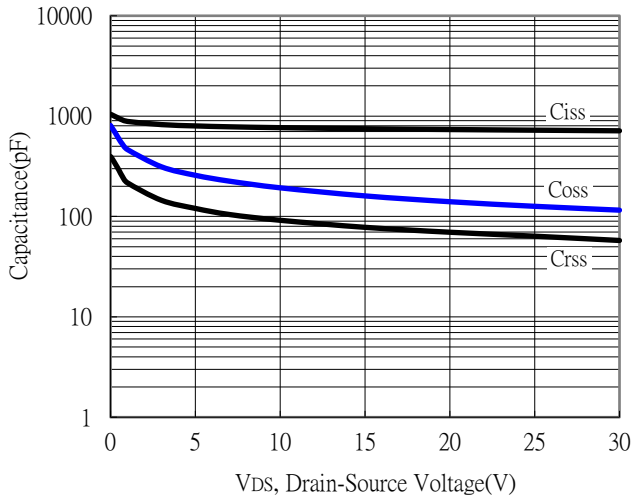

Threshold Voltage vs Junction Temperature

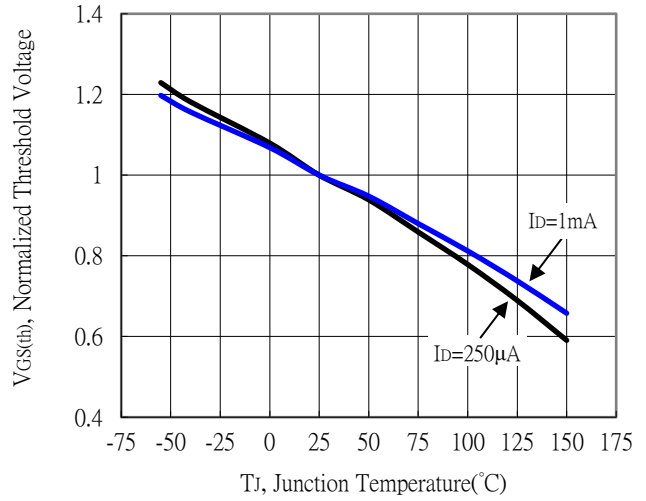

Forward Transfer Admittance vs Drain Current

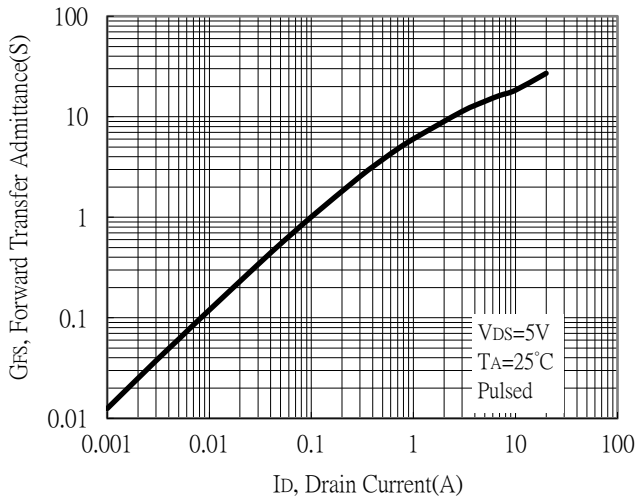

Gate Charge Characteristics

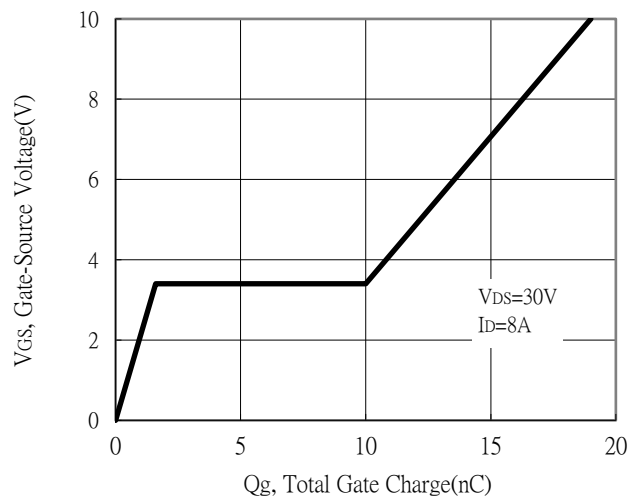

Maximum Safe Operating Area

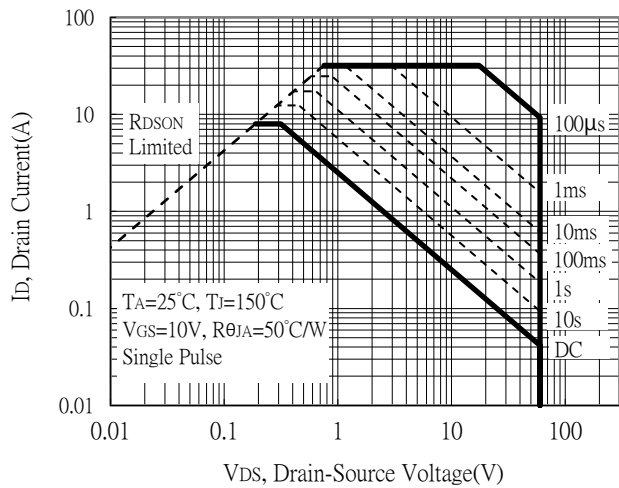

Maximum Drain Current vs Junction Temperature

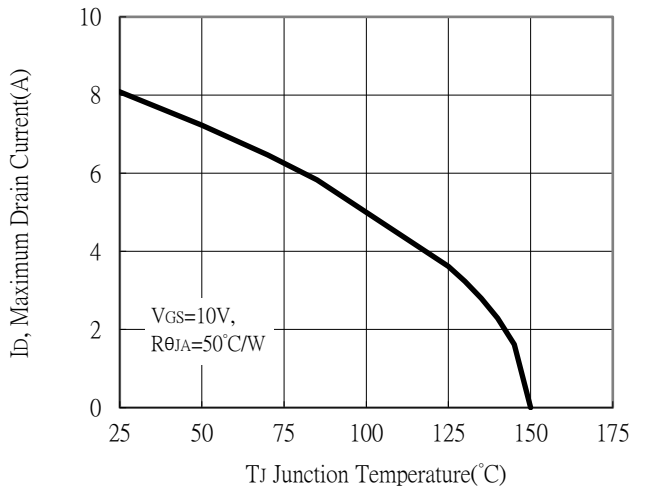

### Typical Characteristics (Cont.)

Single Pulse Power Rating, Junction to Ambient

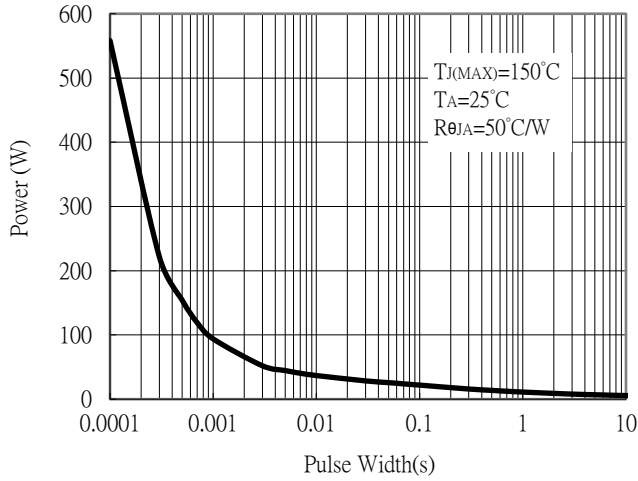

Transient Thermal Response Curves

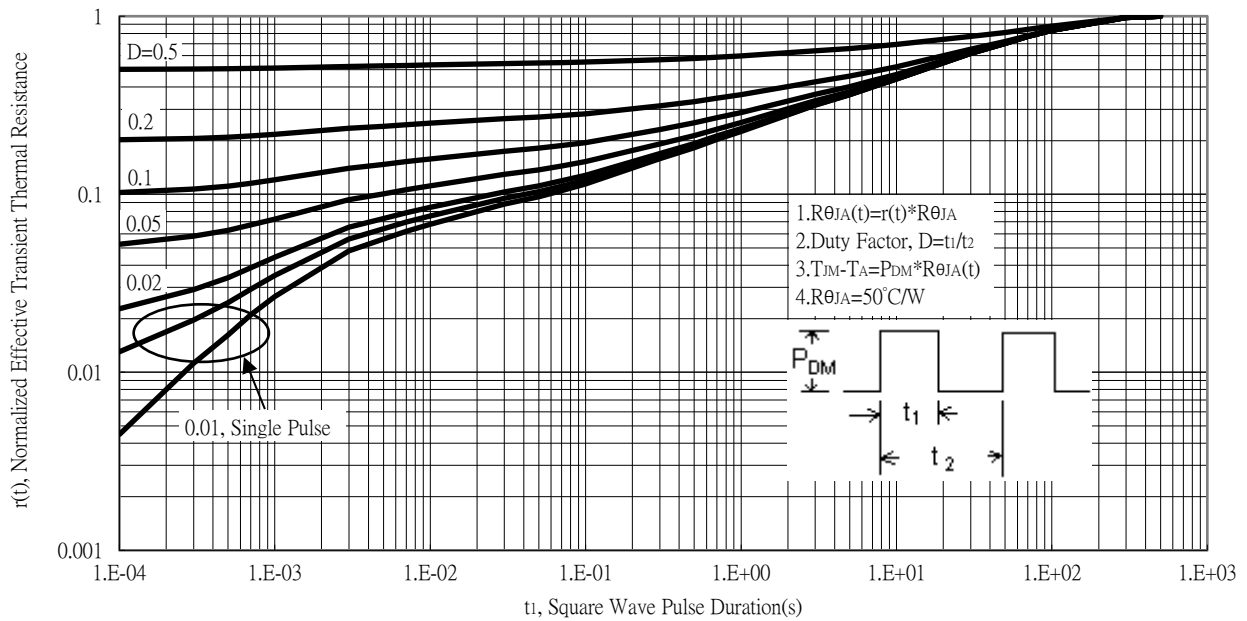

### Recommended soldering footprint

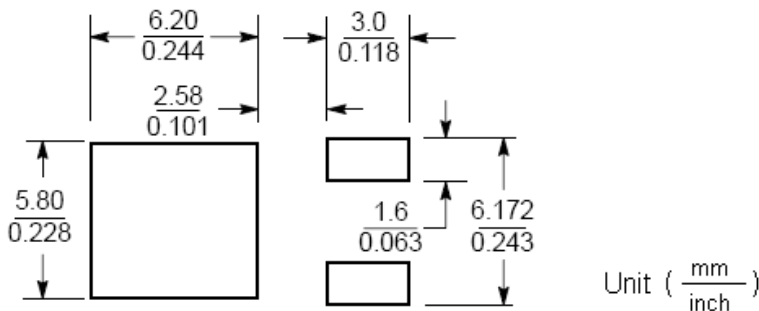

## Reel Dimension

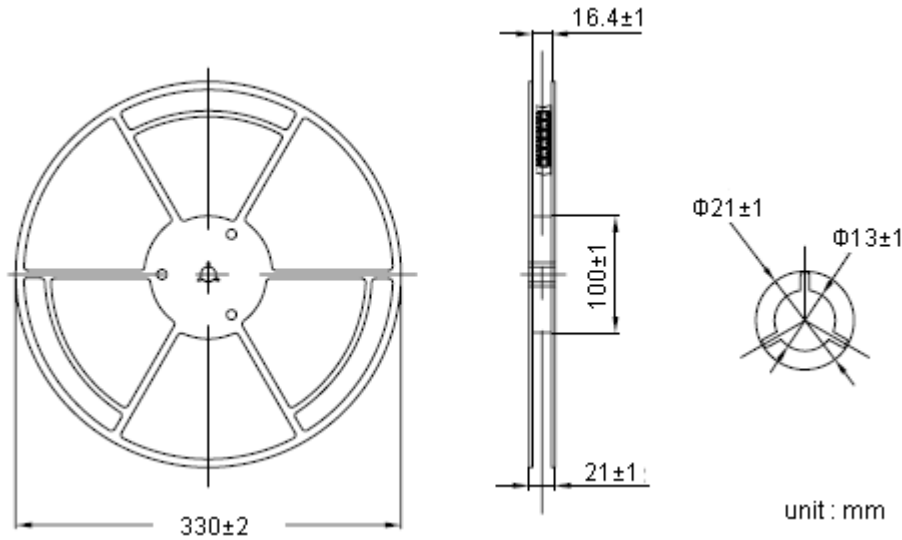

## Carrier Tape Dimension

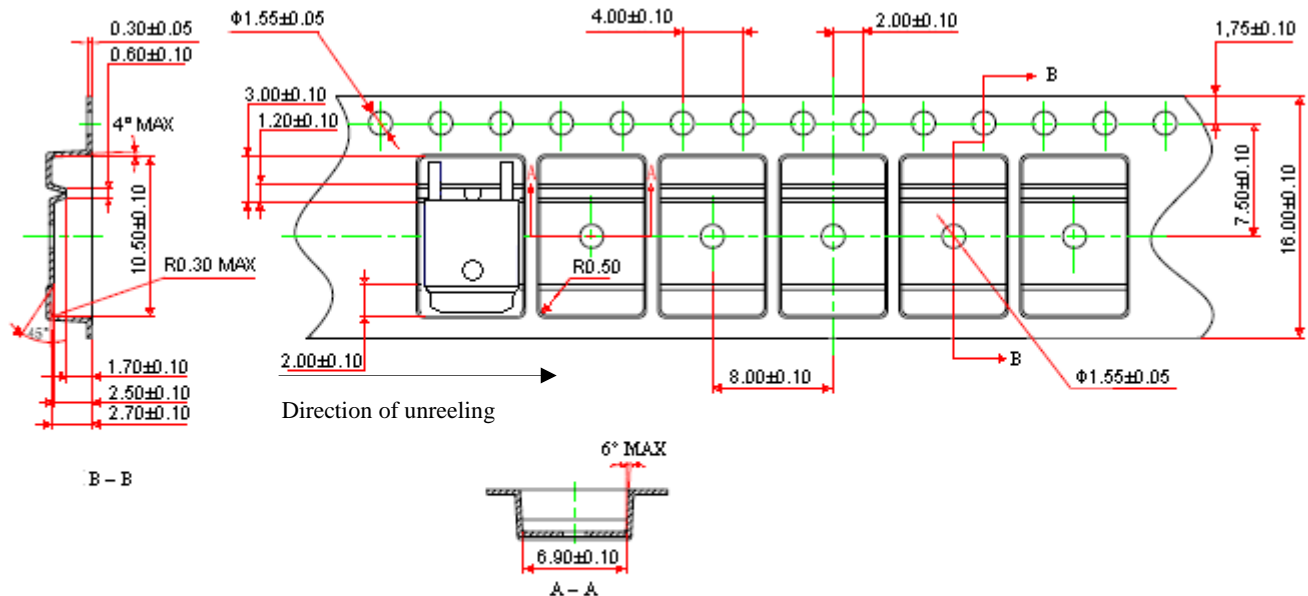

### Notes:

1. 10 sprocket hole pitch cumulative tolerance  $\pm 0.2$ .
2. Camber not to exceed 1mm in 100mm.
3. Material: conductive black polystyrene, antistatic coated :  $10^5 \Omega/\square \sim 10^{11} \Omega/\square$

unit : mm

**TO-252 Dimension**

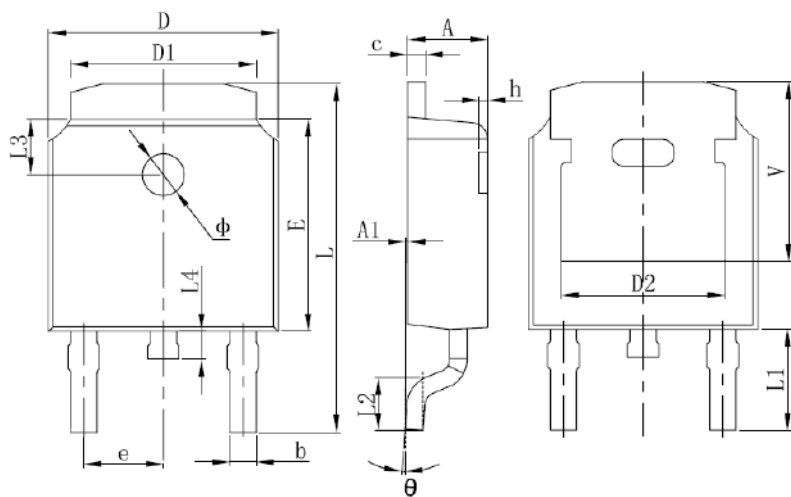

Marking:

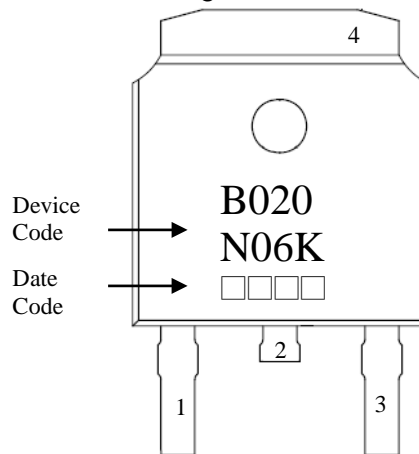

Style: Pin 1.Gate 2.Drain 3.Source  
 4.Drain

3-Lead TO-252 Plastic Surface Mount Package

Date Code :  
 First Code : Last digit of Christian Year  
 Second Code : Month Code : Jan→A, Feb→B, Mar→C, Apr→D,  
 May→E, Jun→F, Jul→G, Aug→H, Sep→J,  
 Oct→K, Nov→L, Dec→M  
 Last Two Codes : Production Serial Code, 01~99

DIM	Inches		Millimeters		DIM	Inches		Millimeters	
	Min.	Max.	Min.	Max.		Min.	Max.	Min.	Max.
A	0.087	0.094	2.200	2.400	L	0.382	0.406	9.712	10.312
A1	0.000	0.005	0.000	0.127	L1	0.114	REF	2.900	REF
b	0.025	0.030	0.635	0.770	L2	0.055	0.067	1.400	1.700
c	0.018	0.023	0.460	0.580	L3	0.063	REF	1.600	REF
D	0.256	0.264	6.500	6.700	L4	0.024	0.039	0.600	1.000
D1	0.201	0.215	5.100	5.460	Φ	0.043	0.051	1.100	1.300
D2	0.190	REF	4.830	REF	θ	0°	8°	0°	8°
E	0.236	0.244	6.000	6.200	h	0.000	0.012	0.000	0.300
e	0.086	0.094	2.186	2.386	v	0.207	REF	5.250	REF