

## N-Channel Enhancement Mode Power MOSFET

### Features:

- Low On Resistance
- Low Gate Charge
- Fast Switching Characteristic

TO-220

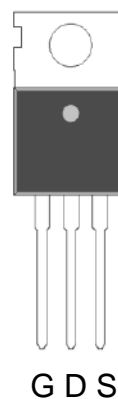

$BV_{DSS}$	100V
$I_D @ V_{GS}=10V, T_C=25^\circ C$	84A
$I_D @ V_{GS}=10V, T_A=25^\circ C$	17A
$R_{DS(ON) typ.} @ V_{GS}=10V, I_D=50A$	5.9m $\Omega$

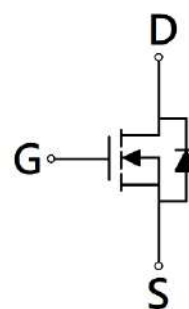

G : Gate S : Source D : Drain

### Ordering Information

Device	Package	Shipping
KE5D0N10BR	TO-220 (Pb-free lead plating package)	50 pcs/tube, 20 tubes/box, 5 boxes / carton

### Absolute Maximum Ratings (T<sub>A</sub>=25°C)

Parameter	Symbol	Limits	Unit
Drain-Source Voltage	V <sub>DS</sub>	100	V
Gate-Source Voltage	V <sub>GS</sub>	±20	
Continuous Drain Current @ V <sub>GS</sub> =10V, T <sub>C</sub> =25°C	I <sub>D</sub>	84	A
Continuous Drain Current @ V <sub>GS</sub> =10V, T <sub>C</sub> =100°C		53	
Continuous Drain Current @ V <sub>GS</sub> =10V, T <sub>A</sub> =25°C		17	
Continuous Drain Current @ V <sub>GS</sub> =10V, T <sub>A</sub> =70°C		14	
Pulsed Drain Current	I <sub>DM</sub>	336	
Continuous Body Diode Forward Current @ T <sub>C</sub> =25°C	I <sub>S</sub>	84	mJ
Avalanche Current @ L=0.1mH	I <sub>AS</sub>	45	
Avalanche Energy @ L=0.5mH	E <sub>AS</sub>	156	W
Total Power Dissipation	T <sub>C</sub> =25°C	104	
	T <sub>C</sub> =100°C	42	
	T <sub>A</sub> =25°C	4.3	
	T <sub>A</sub> =70°C	2.8	
Operating Junction and Storage Temperature Range	T <sub>J</sub> , T <sub>stg</sub>	-55~+150	°C

### Thermal Data

Parameter	Symbol	Steady State	Unit
Thermal Resistance, Junction-to-case	R <sub>θJC</sub>	1.2	°C/W
Thermal Resistance, Junction-to-ambient	R <sub>θJA</sub>	29	

Note:

- \*a. The power dissipation P<sub>D</sub> is based on T<sub>J(MAX)</sub>=150°C, using junction-to-case thermal resistance, and is more useful in setting the upper dissipation limit for cases where additional heatsinking is used.
- \*b. The value of R<sub>θJA</sub> is measured with the device mounted on 1 in<sup>2</sup>FR -4 board with 2 oz. copper, in a still air environment with T<sub>A</sub>=25°C. The power dissipation P<sub>D</sub> is based on R<sub>θJA</sub> and the maximum allowed junction temperature of 150°C. The value in any given application depends on the user's specific board design.
- \*c. Repetitive rating, pulse width limited by junction temperature T<sub>J(MAX)</sub>=150°C. Ratings are based on low frequency and low duty cycles to keep initial T<sub>J</sub>=25°C.

**Electrical Characteristics (T<sub>A</sub>=25°C, unless otherwise specified)**

Symbol	Min.	Typ.	Max.	Unit	Test Conditions
<b>Static</b>					
BV <sub>DSS</sub>	100	-	-	V	V <sub>GS</sub> =0V, I <sub>D</sub> =250μA
V <sub>GS(th)</sub>	2	-	4		V <sub>DS</sub> =V <sub>GS</sub> , I <sub>D</sub> =250μA
G <sub>FS</sub>	-	17	-	S	V <sub>DS</sub> =10V, I <sub>D</sub> =10A
I <sub>GSS</sub>	-	-	±100	nA	V <sub>GS</sub> =±20V, V <sub>DS</sub> =0V
I <sub>DSS</sub>	-	-	1	μA	V <sub>DS</sub> =80V, V <sub>GS</sub> =0V
R <sub>DS(ON)</sub>	-	5.9	8	mΩ	V <sub>GS</sub> =10V, I <sub>D</sub> =50A
<b>Dynamic</b>					
C <sub>iss</sub>	-	3400	-	pF	V <sub>DS</sub> =50V, V <sub>GS</sub> =0V, f=1MHz
C <sub>oss</sub>	-	450	-		
C <sub>rss</sub>	-	30	-		
R <sub>g</sub>	-	1.4	-	Ω	f=1MHz
Q <sub>g</sub> *1, 2	-	50	-	nC	V <sub>DS</sub> =80V, I <sub>D</sub> =50A, V <sub>GS</sub> =10V
Q <sub>gs</sub> *1, 2	-	20	-		
Q <sub>gd</sub> *1, 2	-	10	-		
t <sub>d(ON)</sub> *1, 2	-	30	-	ns	V <sub>DS</sub> =50V, I <sub>D</sub> =20A, V <sub>GS</sub> =10V, R <sub>GS</sub> =3Ω
t <sub>r</sub> *1, 2	-	18	-		
t <sub>d(OFF)</sub> *1, 2	-	50	-		
t <sub>f</sub> *1, 2	-	12	-		
<b>Source-Drain Diode</b>					
V <sub>SD</sub> *1	-	0.8	1.2	V	I <sub>S</sub> =20A, V <sub>GS</sub> =0V
t <sub>rr</sub>	-	50	-	ns	I <sub>F</sub> =20A, dI <sub>F</sub> /dt=100A/μs
Q <sub>rr</sub>	-	80	-	nC	

Note:

\*1. Pulse Test : Pulse Width ≤300μs, Duty Cycle≤2%

\*2. Independent of operating temperature

## Typical Characteristics

Typical Output Characteristics

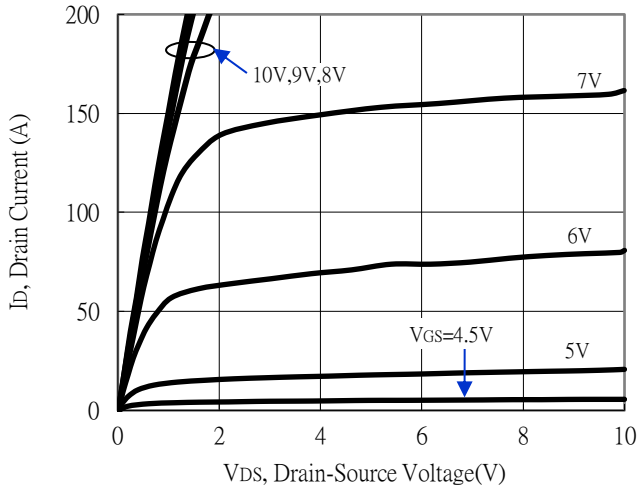

Breakdown Voltage vs Ambient Temperature

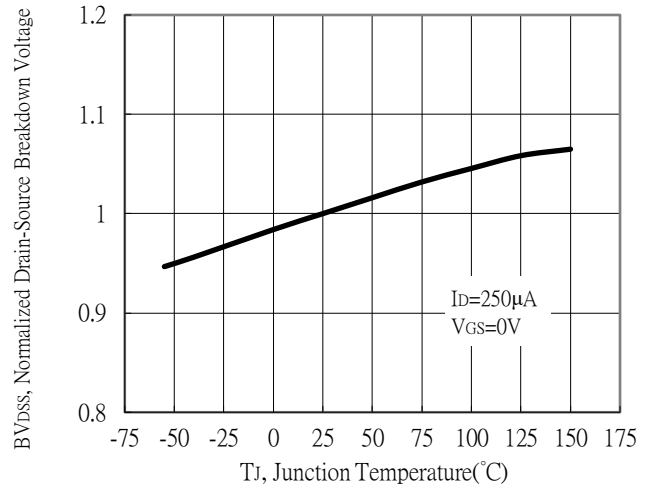

Static Drain-Source On-State resistance vs Drain Current

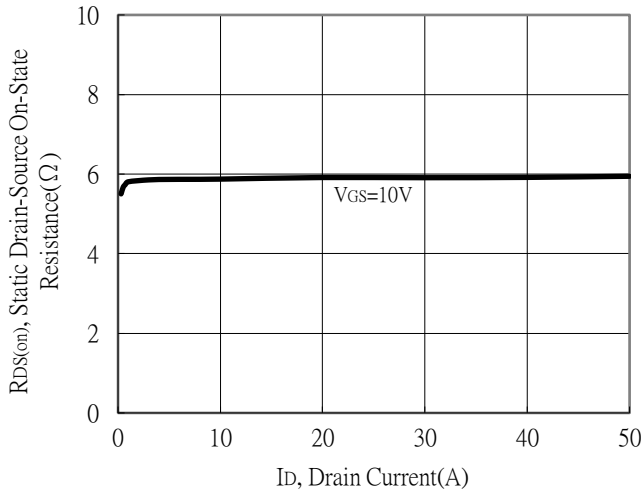

Body Diode Current vs Source-Drain Voltage

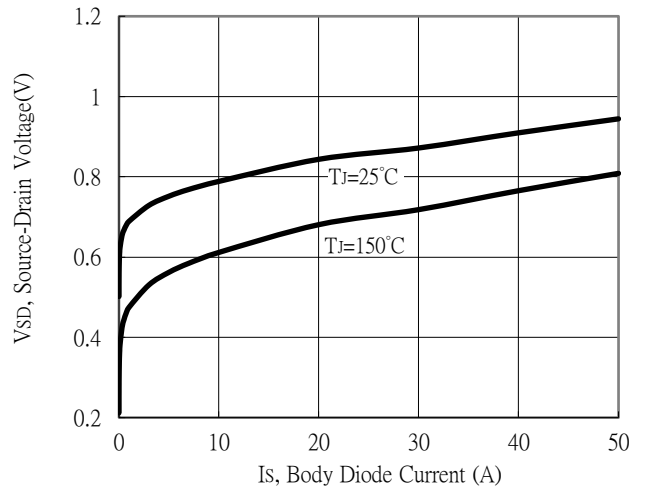

Static Drain-Source On-State Resistance vs Gate-Source Voltage

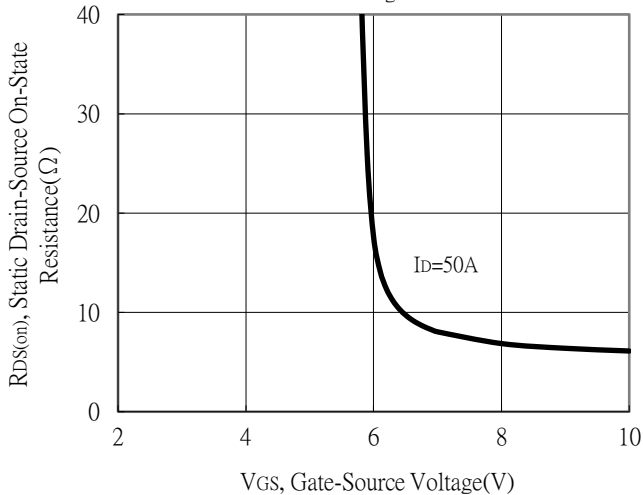

Drain-Source On-State Resistance vs Junction Temperature

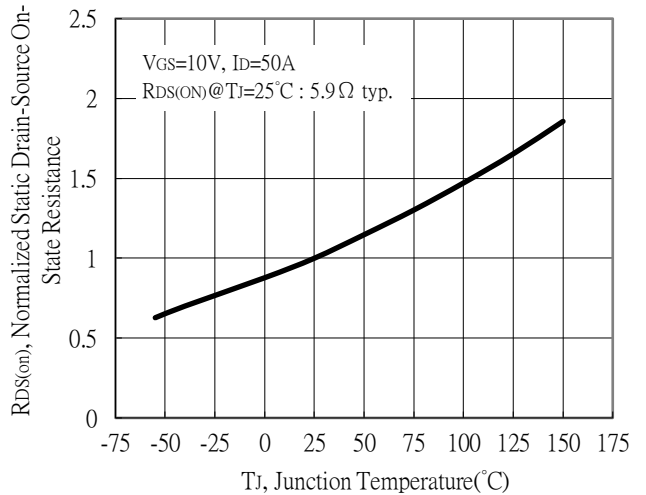

**Typical Characteristics (Cont.)**

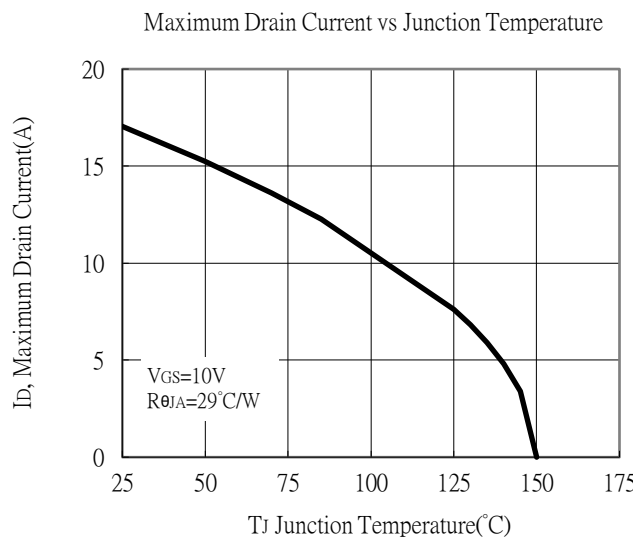
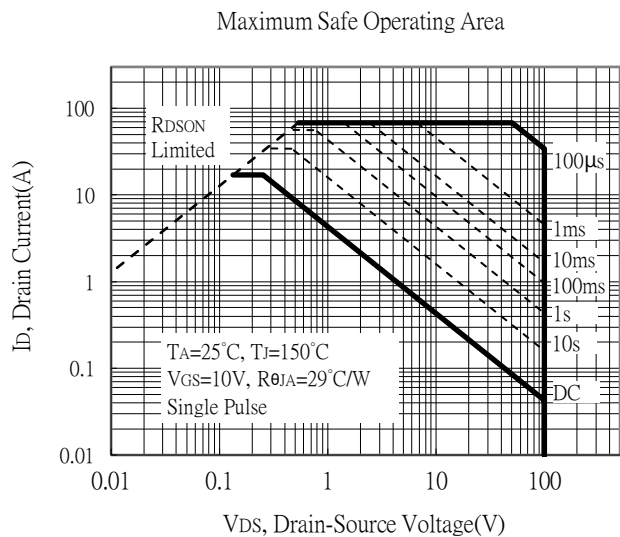
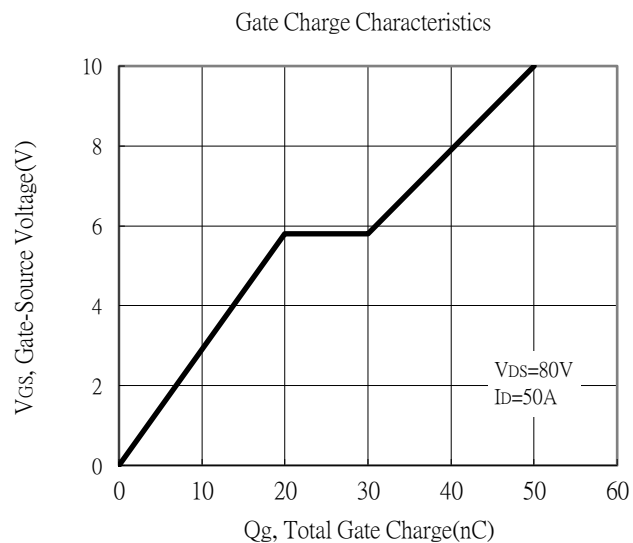
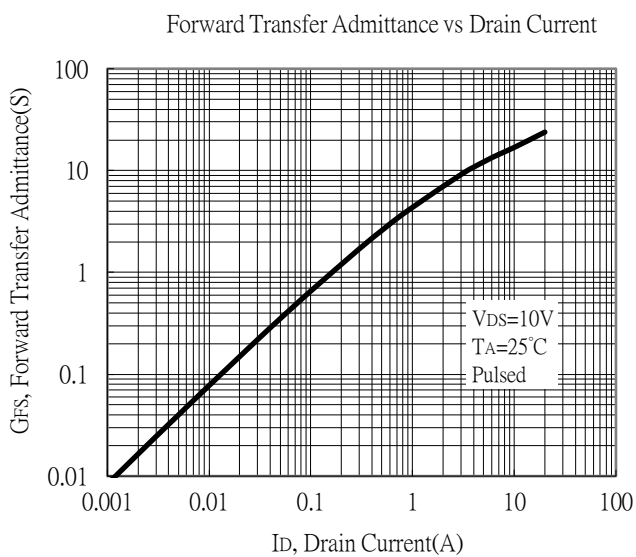
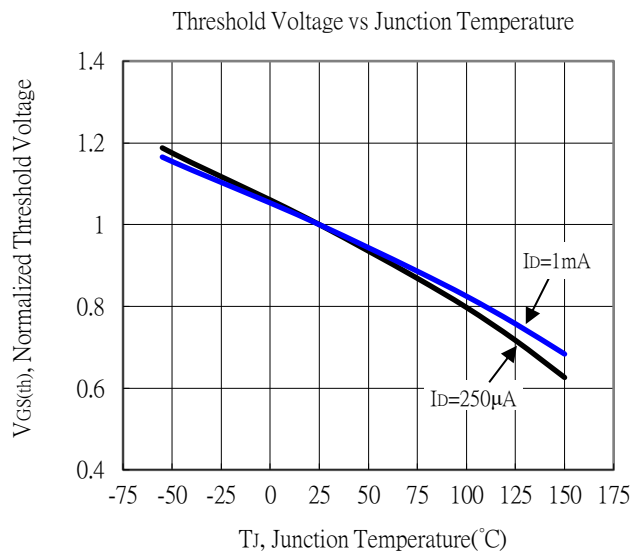
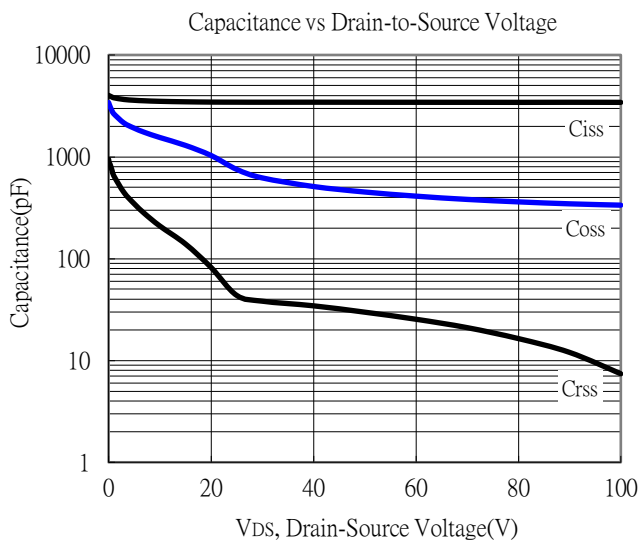

**Typical Characteristics (Cont.)**

Single Pulse Power Rating, Junction to Ambient

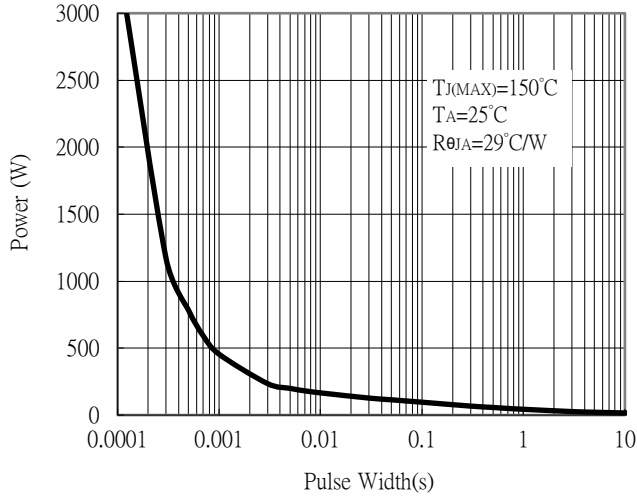

Transient Thermal Response Curves

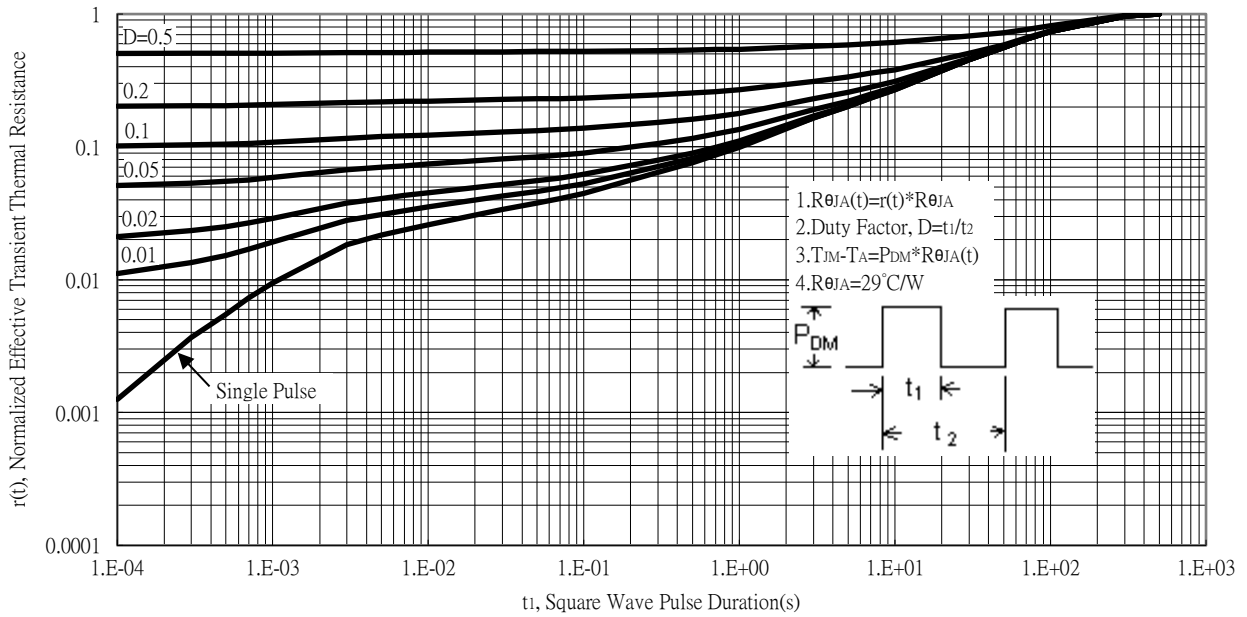

**TO-220 Dimension**

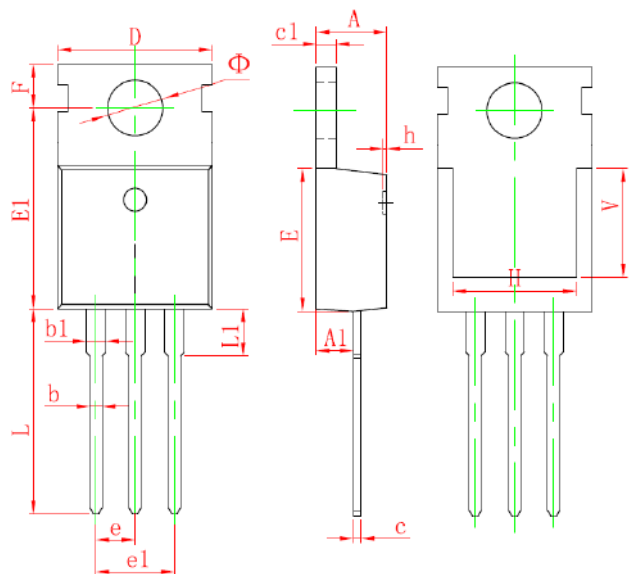

Marking:

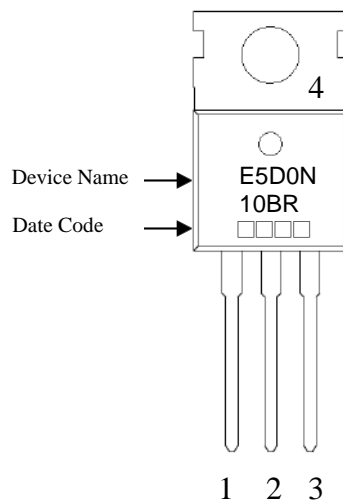

Date Code(counting from left to right) :  
 1<sup>st</sup> code: year code, the last digit of Christian year  
 2<sup>nd</sup> code : month code, Jan→A, Feb→B, Mar→C,  
 Apr→D, May→E, Jun→F, Jul→G, Aug→H,  
 Sep→J, Oct→K, Nov→L, Dec→M  
 3<sup>rd</sup> and 4<sup>th</sup> codes : production serial number, 01~99

Style: Pin 1.Gate 2.Drain 3.Source  
 4.Drain

3-Lead TO-220 Plastic Package

DIM	Millimeters		Inches		DIM	Millimeters		Inches	
	Min.	Max.	Min.	Max.		Min.	Max.	Min.	Max.
A	4.400	4.600	0.173	0.181	e	2.540	TYP	0.100	TYP
A1	2.250	2.550	0.089	0.100	e1	4.980	5.180	0.196	0.204
b	0.710	0.910	0.028	0.036	F	2.650	2.950	0.104	0.116
b1	1.170	1.370	0.046	0.054	H	7.900	8.100	0.311	0.319
c	0.330	0.650	0.013	0.026	h	0.000	0.300	0.000	0.012
c1	1.200	1.400	0.047	0.055	L	12.900	13.400	0.508	0.528
D	9.910	10.250	0.390	0.404	L1	2.850	3.250	0.112	0.128
E	8.950	9.750	0.352	0.384	V	7.500	REF	0.295	REF
E1	12.650	12.950	0.498	0.510	Φ	3.400	3.800	0.134	0.150