

## TO-252-2L Plastic-Encapsulate Diodes

SUPER FAST RECOVER RECTIFIER

### Features:

- Ultrafast 35ns Recovery Times
- High Voltage Capability to 600V
- Low Reverse Leakage Current

### MAIN CHARACTERISTICS

$I_O$	<b>16A</b>
$V_{RRM}$	<b>600 V</b>
$T_j$	<b>150 °C</b>
$V_{F(typ)}$	<b>1.3V (@<math>T_j=125^\circ\text{C}</math>)</b>

### MARKING

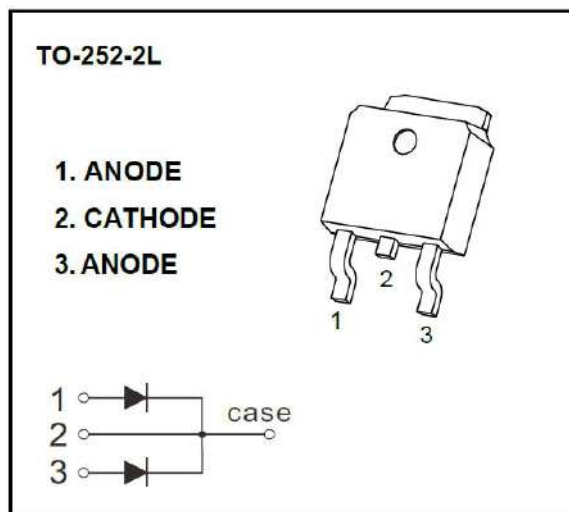

### MAXIMUM RATINGS ( $T_a=25^\circ\text{C}$ unless otherwise noted )

Symbol	Parameter	KMURD1660CT	Unit
$V_{RRM}$	Peak repetitive reverse voltage	600	V
$V_{RWM}$	Working peak reverse voltage		
$V_R$	DC blocking voltage		
$V_{R(RMS)}$	RMS reverse voltage	420	V
$I_O$	Average rectified output current@ Per leg	8.0	A
	Average rectified output current@ Total device	16.0	A
$I_{FSM}$	Non-Repetitive peak forward surge current 8.3ms half sine wave	175	A
$R_{\theta JC}$	Typical thermal resistance	4.5	°C/W
$R_{\theta JA}$	Thermal resistance from junction to ambient	62.5	
$T_j$	Operating Junction Temperature Range	-55 ~ +150	°C
$T_{stg}$	Storage Temperature Range	-55 ~ +150	°C

### ELECTRICAL CHARACTERISTICS ( $T_a=25^\circ\text{C}$ unless otherwise specified)

Parameter	Symbol	Test conditions	Min	Typ	Max	Unit
Reverse voltage	$V_{(BR)}$	$I_R=100\mu\text{A}$	600			V
Reverse current	$I_R$	$V_R=600\text{V}$	$T_j=25^\circ\text{C}$	0.5	2	$\mu\text{A}$
			$T_j=125^\circ\text{C}$	20	200	$\mu\text{A}$
Forward voltage	$V_F$	$I_F=8.0\text{A}$	$T_j=25^\circ\text{C}$	1.3	1.7	V
			$T_j=125^\circ\text{C}$	1.3		V
Typical total capacitance	$C_{tot}$	$V_R=4.0\text{V}, f=1\text{MHz}$		14		pF
Reverse recovery time	$t_{rr}$	$I_F=0.5\text{A}, I_R=1\text{A}, I_{rr}=0.25\text{A}$			35	ns

**Typical Characteristics**

FIG.1: FORWARD CURRENT DERATING CURVE

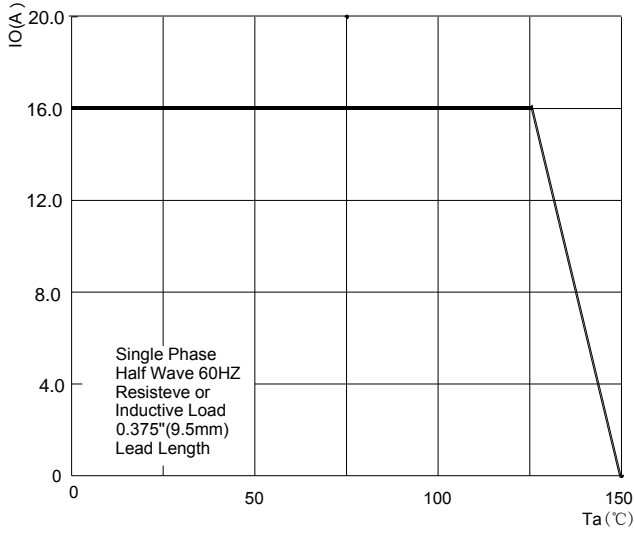
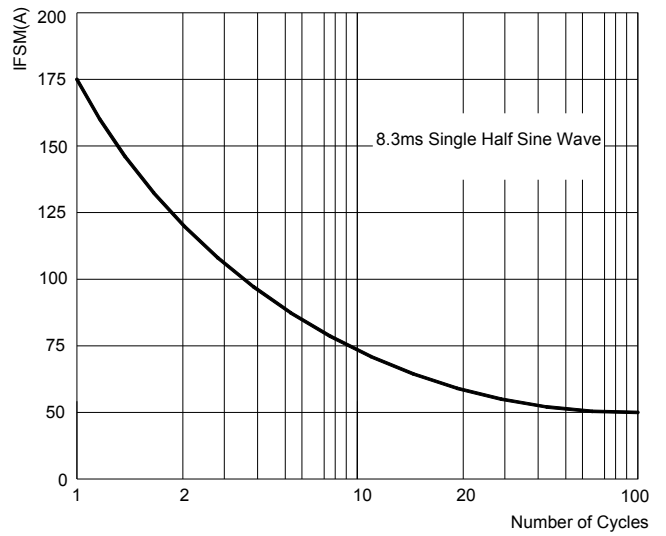

FIG.2: MAXIMUM NON-REPETITIVE FORWARD SURGE CURRENT



TYPICAL FORWARD CHARACTERISTICS

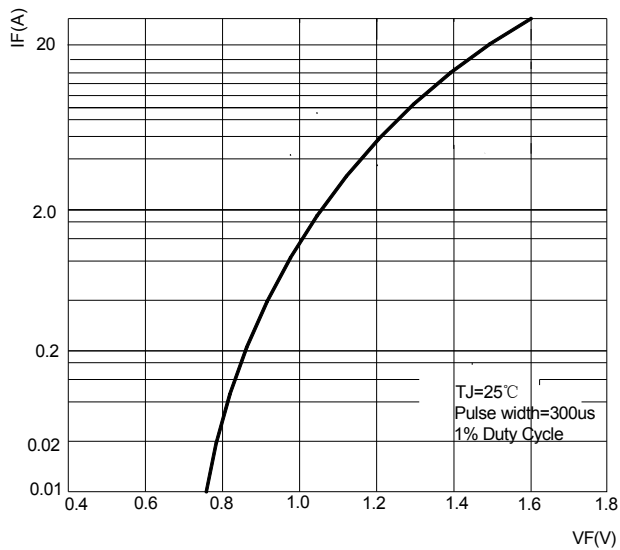

FIG.4:TYPICAL REVERSE CHARACTERISTICS

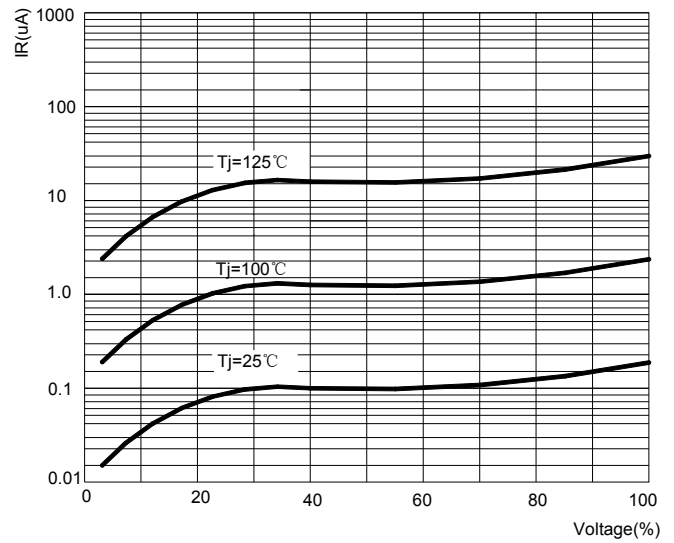
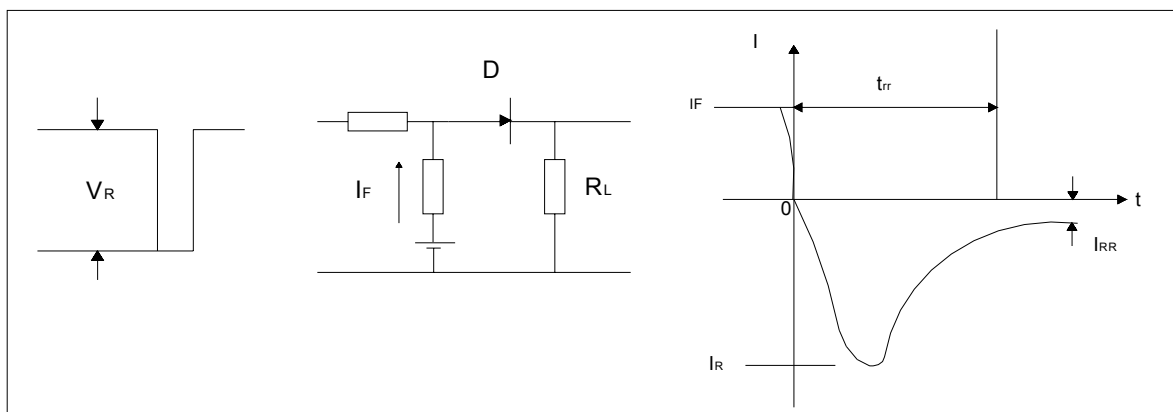
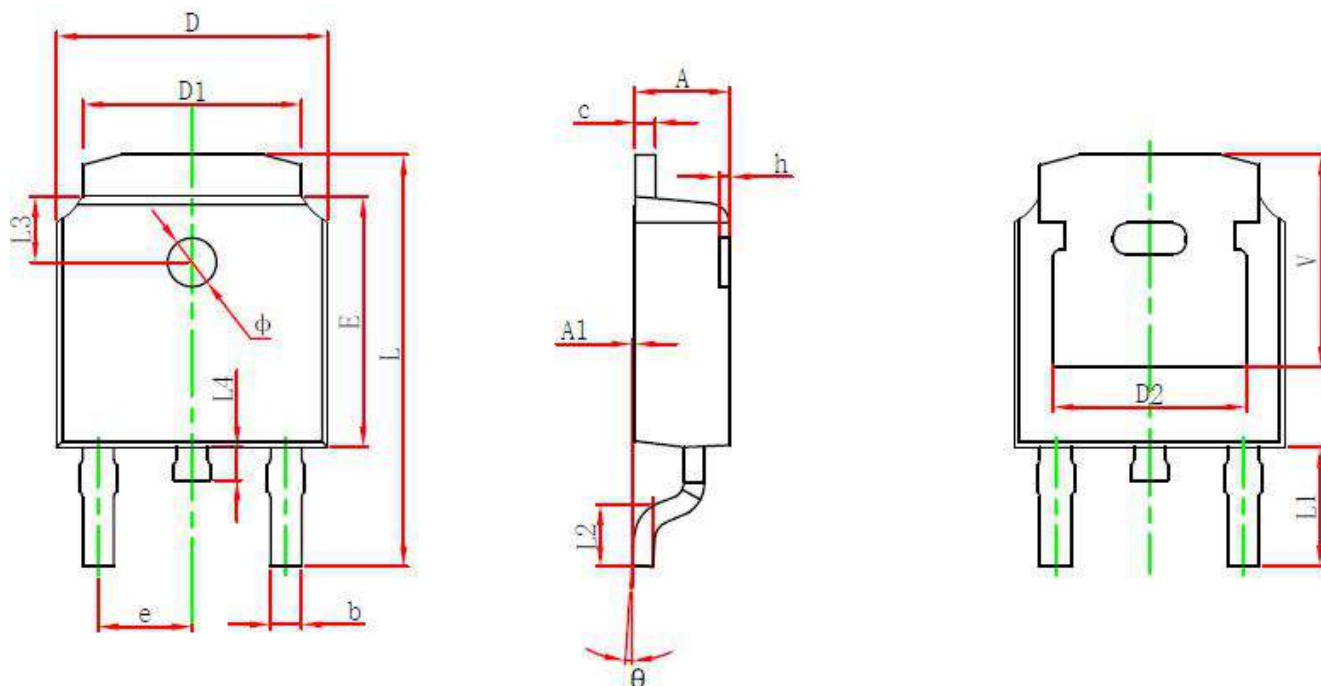

FIG.7: Diagram of circuit and Testing wave form of reverse recovery time



TO-252-2L PACKAGE OUTLINE DIMENSIONS



Symbol	Dimensions In Millimeters		Dimensions In Inches	
	Min.	Max.	Min.	Max.
A	2.200	2.400	0.087	0.094
A1	0.000	0.127	0.000	0.005
b	0.635	0.770	0.025	0.030
c	0.460	0.580	0.018	0.023
D	6.500	6.700	0.256	0.264
D1	5.100	5.460	0.201	0.215
D2	4.830 REF.		0.190 REF.	
E	6.000	6.200	0.236	0.244
e	2.186	2.386	0.086	0.094
L	9.712	10.312	0.382	0.406
L1	2.900 REF.		0.114 REF.	
L2	1.400	1.700	0.055	0.067
L3	1.600 REF.		0.063 REF.	
L4	0.600	1.000	0.024	0.039
Φ	1.100	1.300	0.043	0.051
θ	0°	8°	0°	8°
h	0.000	0.300	0.000	0.012
V	5.250 REF.		0.207 REF.	

TO-252-2L SUGGESTED PAD LAYOUT

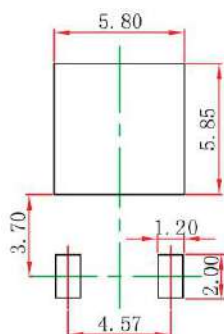

Note:

1. Controlling dimension in millimeters.
2. General tolerance:  $\pm 0.05\text{mm}$ .
3. The pad layout is for reference purpose only.

**TO-252-2L TAPE AND REEL**

**TO-252 Embossed Carrier Tape**

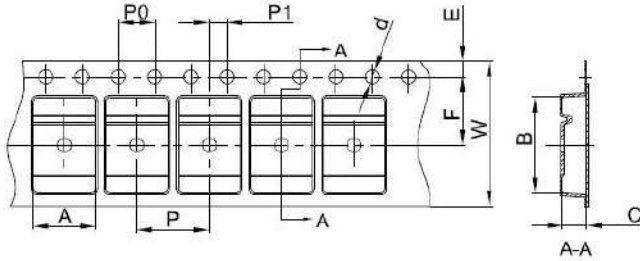

**Packaging Description:**

TO-252 parts are shipped in tape. The carrier tape is made from a dissipative (carbon filled) polycarbonate resin. The cover tape is a multilayer film (Heat Activated Adhesive in nature) primarily composed of polyester film, adhesive layer, sealant, and anti-static sprayed agent. These reeled parts in standard option are shipped with 25,00 units per 13" or 33.0 cm diameter reel. The reels are clear in color and is made of polystyrene plastic (anti-static coated),

Dimensions are in millimeter										
Pkg type	A	B	C	d	E	F	P0	P	P1	W
TO-252	6.90	10.50	2.70	Ø1.55	1.75	7.50	4.00	8.00	2.00	16.00

**TO-252 Tape Leader and Trailer**

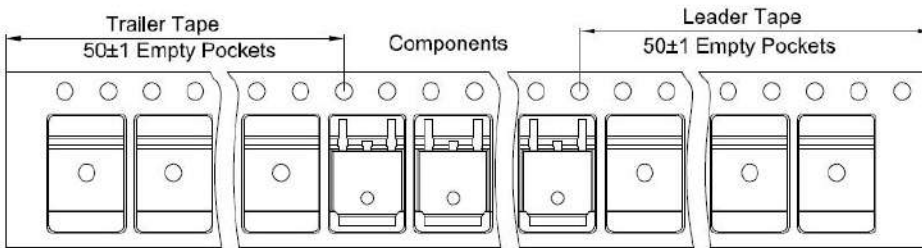

**TO-252 Reel**

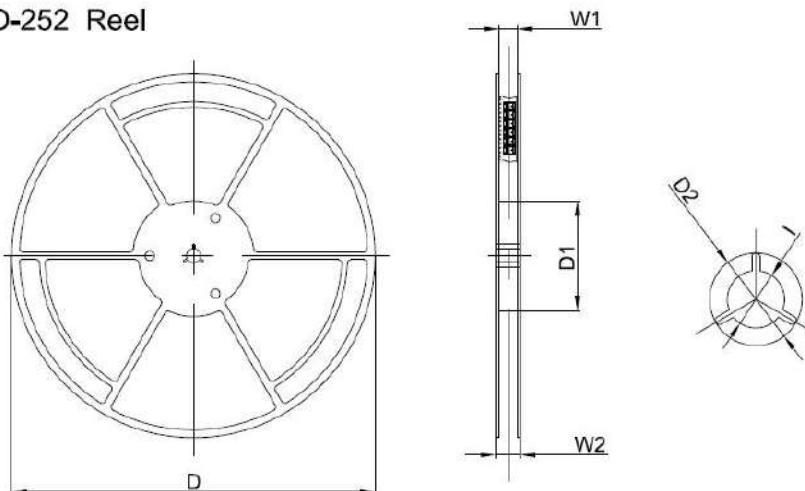

Dimensions are in millimeter						
Reel Option	D	D1	D2	W1	W2	I
13" Dia	330.00	100.00	Ø21.00	16.40	21.00	Ø13.00

REEL	Reel Size	Box	Box Size(mm)	Carton	Carton Size(mm)	G.W.(kg)
2,500 pcs	13inch	2,500 pcs	340×336×29	25,000 pcs	353×346×365	