

# GLASS PASSIVATED SUPER FAST RECTIFIER

Reverse Voltage - 200 -600 Volts Forward Current - 10.0Amperes

## Features:

- ✧ High efficiency, Low VF
- ✧ High current capability
- ✧ High reliability
- ✧ High surge current capability
- ✧ For use in low voltage, high frequency inverter, free wheeling, and polarity protection application.

## Mechanical Data:

- ✧ Cases: TO-220AC molded plastic
- ✧ Epoxy: UL 94V-0 rate flame retardant
- ✧ Terminals: Pure tin plated, lead free, solderable per MIL-STD-202, Method 208 guaranteed
- ✧ Polarity: As marked
- ✧ High temperature soldering guaranteed:  
260°C/10 seconds/.25",(.635mm) from case.
- ✧ Weight: 2.24 grams

## ITO-220AC

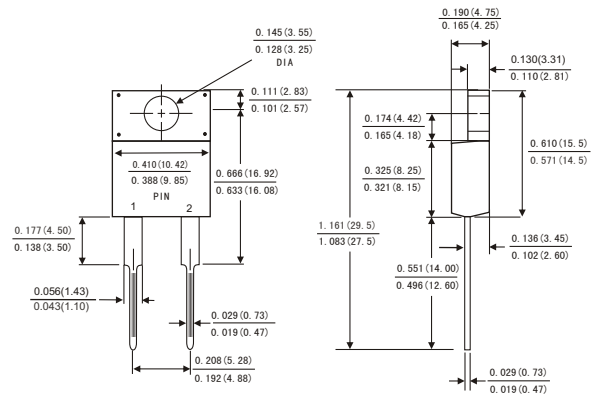

Dimensions in inches and (millimeters)

## Maximum Ratings and Electrical Characteristics

Rating at 25°C ambient temperature unless otherwise specified.

Single phase, half wave, 60 Hz, resistive or inductive load.

For capacitive load, derate current by 20%

Type Number	Symbol	KMURF820	KMURF840	KMURF860	Units
Maximum Reverse Peak Reverse Voltage	$V_{RRM}$	200	400	600	V
Maximum RMS Voltage	$V_{RMS}$	140	280	420	V
Maximum DC Blocking Voltage	$V_{DC}$	200	400	600	V
Maximum Average Forward Rectified Current .375"(9.5mm) Lead Length (See Fig. 1)	$I_{(AV)}$	8.0			A
Peak Forward Surge Current, 8.3 ms Single Half Sine-wave Superimposed on Rated Load (JEDEC method )	$I_{FSM}$	100			A
Maximum Instantaneous Forward Voltage @ 8.0A	$V_F$	0.975	1.30	1.7	V
Maximum DC Reverse Current @ $T_C=25^\circ\text{C}$ at Rated DC Blocking Voltage @ $T_C=125^\circ\text{C}$ (Note 4)	$I_R$	5.0 250			$\mu\text{A}$ $\mu\text{A}$
Maximum Reverse Recovery Time ( Note 2 )	$T_{rr}$	25	50		nS
Maximum Forward Recovery Time TFR ( $I_F=1.0\text{A}$ , $di/dt = 50\text{A}/\mu\text{S}$ ),	$T_{fr}$	35	50		nS
Typical Thermal Resistance (Note 3)	$R_{\theta JC}$	3.0	2.0		$^\circ\text{C}/\text{W}$
Operating Temperature Range	$T_J$	-65 to +175			$^\circ\text{C}$
Storage Temperature Range	$T_{STG}$	-65 to +175			$^\circ\text{C}$

- Notes:
1. Measured at 1 MHz and Applied Reverse Voltage of 4.0 Volts D.C.
  2. Reverse Recovery Test Conditions:  $I_F=0.5\text{A}$ ,  $I_R=1.0\text{A}$ ,  $I_{RR}=0.25\text{A}$
  3. Thermal Resistance from Junction to Case, Mounted on Heatsink Size of 2" x 3" x 0.25" Al-Plate.
  4. Pulse lest:  $t_p = 300 \mu\text{S}$ , Duty Cycle < 2%.

**RATINGS AND CHARACTERISTIC CURVES ( KMURF820 THRU KMURF860 )**

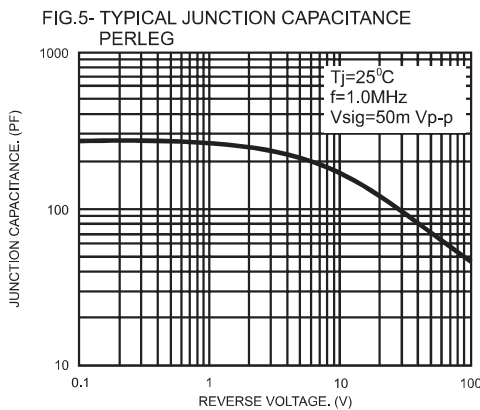
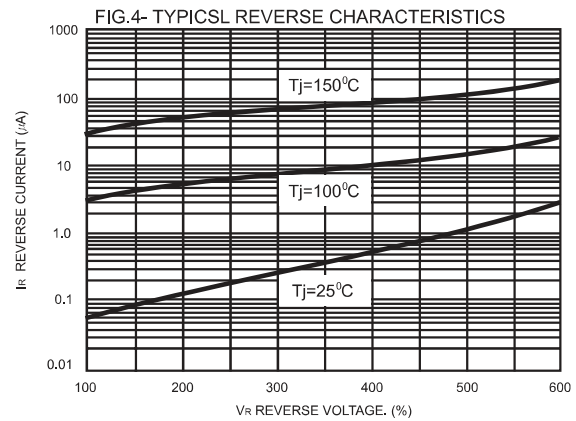
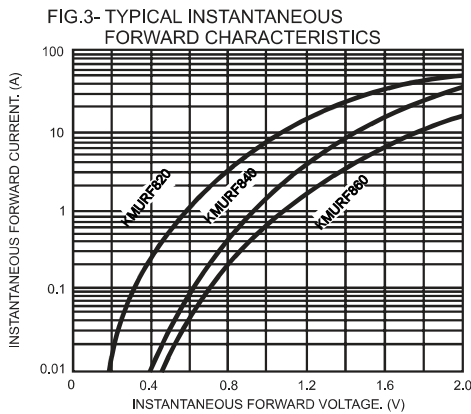
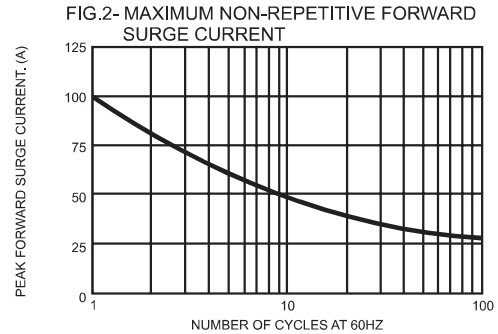
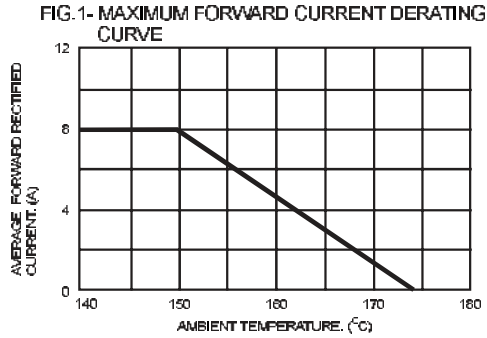

**FIG.6- REVERSE RECOVERY TIME CHARACTERISTIC AND TEST CIRCUIT DIAGRAM**

